

DEVELOPMENT OF COST EFFECTIVE PLC TRAINING KIT BY USING  
ARDUINO PLATFORM (PLCDUINO)

MOHD SAFIT BIN MOHD SAMSUDIN

A project report submitted in partial  
fulfillment of the requirement for the award of the  
Degree of Master of Electrical Engineering

Faculty of Electrical and Electronics Engineering  
Universiti Tun Hussein Onn Malaysia

JANUARY 2015

## ABSTRACT

Programmable Logic Controller (PLC) is an industry demand practical based subject which required hands on experience of programming and hardware wiring. Because of such nature, the course is usually delivered with the help of PLC training kit. The kit generally consists of PLC incorporating switches as an input and lamps as an output. However cost of owning a PLC training kit is quite expensive and the PLC itself dominates the total cost. In this project, a solution for catering such an issue is proposed by introducing PLCduino training kit. Basically the systems use standard PLC Ladder diagram and implement it under cheap Arduino microcontroller platform. The Ladder instruction set is automatically converted to the Arduino language with the usage of LDuino software, while the PLC voltage requirement is fulfilled by using couple of relay boards. The system is expected to deliver the same performance of standard PLC system with more than 50 percent cheaper in price.



## ABSTRAK

Kebolehan, kemahiran dan pengalaman dalam menggunakan Programmable Logic Controller (PLC) sebagai pengawal mesin mempunyai permintaan yang tinggi oleh industri. Pengajaran dan pembelajaran PLC ini biasanya disampaikan dengan bantuan peralatan kit latihan. Kit ini umumnya terdiri daripada PLC menggabungkan switch sebagai input dan lampu sebagai output. Namun kos memiliki kit latihan PLC adalah cukup mahal dan PLC itu sendiri mendominasi jumlah keseluruhan kos. Dalam projek ini, satu penyelesaian bagi mengatasi masalah ini dicadangkan dengan memperkenalkan peralatan kit latihan PLCduino. Pada dasarnya sistem ini menggunakan rajah tangga sebagai bahasa pengaturcaraan dan Arduino platform sebagai perkakasan pengawal. Set arahan rajah tangga secara automatik ditukar kepada bahasa Arduino dengan penggunaan perisian Lduino manakala syarat masukan atau keluaran PLC menggunakan beberapa komponen relay. Sistem ini diharapkan untuk memberikan prestasi yang sama seperti sebuah PLC standard dengan kos yang lebih murah lebih kurang sebanyak 50 peratus.



## TABLE OF CONTENTS

	<b>TITLE</b>	<b>i</b>
	<b>DECLARATION</b>	<b>ii</b>
	<b>DEDICATION</b>	<b>iii</b>
	<b>ACKNOWLEDGEMENT</b>	<b>iv</b>
	<b>ABSTRACT</b>	<b>v</b>
	<b>TABLE OF CONTENTS</b>	<b>vii</b>
	<b>LIST OF TABLES</b>	<b>ix</b>
	<b>LIST OF FIGURES</b>	<b>x</b>
	<b>LIST OF SYMBOLS AND ABBREVIATIONS</b>	<b>xii</b>
	<b>LIST OF APPENDICES</b>	<b>xiv</b>
<b>CHAPTER 1</b>	<b>INTRODUCTION</b>	<b>1</b>
	1.1 Project overview	1
	1.2 Problem statement	2
	1.3 Project objective	3
	1.4 Project scope	3
	1.5 Project report layout	4
<b>CHAPTER 2</b>	<b>LITERATURE REVIEW</b>	<b>5</b>
	2.1 Programmable Logic Controller (PLC)	5
	2.2 Programmable Interface Controller (PIC)	6
	2.3 Difference between PLC and PIC	7
	2.4 Microcontroller as PLC	7
	2.5 Previous case study	8
	2.5.1 Software simulator kit	8

	2.5.2	Real PLC training kit	9
	2.5.3	Micro controller as PLC training kit	12
	2.5.4	Combination PLC with micro controller	14
<b>CHAPTER 3</b>		<b>METHODOLOGY</b>	<b>17</b>
	3.1	Introduction	17
	3.2	Experimental phase	18
	3.2.1	Hardware development	18
	3.2.2	Software testing	20
	3.3	Hardware design	22
	3.4	Software design	27
<b>CHAPTER 4</b>		<b>RESULT AND ANALYSIS</b>	<b>32</b>
	4.1	Implementation of PLCduino	32
	4.2	Survey 1: Microcontroller PIC16F877A vs PLCmicro	34
	4.2.1	Assessment	36
	4.3	Survey 2: PLC Nais vs PLCduino	38
	4.4	Survey 3: Price of PLC compare to PIC	42
	4.4.1	A practical example using Proteus Software	43
<b>CHAPTER 5</b>		<b>CONCLUSION AND RECOMMENDATION</b>	<b>47</b>
	5.1	Conclusion	42
	5.2	Recommendation	43
		<b>REFERENCES</b>	<b>51</b>
		<b>APPENDICES</b>	<b>54</b>

**LIST OF TABLES**

2.1	Comparison between PIC and PLC	7
3.1	Specifications & Features of PLCduino	23



**PTTA UTHM**  
PERPUSTAKAAN TUNKU TUN AMINAH

## LIST OF FIGURES

2.1	Overall view of PLC Kit	10
2.2	Overview of PLC Workbench	11
2.3	The architecture of an embedded PLC	12
3.1	Hardware development	18
3.2	Microcontroller Selection and Schematic	19
3.3	Pull down / active high circuit	19
3.4	Ladder diagram for blinking Led using LDmicro	20
3.5	Simulating the Program	21
3.6	Assign pin for Input and Output	21
3.7	Uploading IHEX file into PIC16F877A	22
3.8	The main component's used in development	23
3.9	The architecture of PLCduino	24
3.10	External circuit of digital input	24
3.11	Pull up / active low circuit	25
3.12	Debounce	26
3.13	External circuit of digital output	28
3.14	The example of creating function of LD language	28
3.15	System flowchart	28
3.16	LDuino user interface	30
3.17	Ladder Diagram Editor	30
3.18	(a) Table of elements and (b) Add new element from Element's Properties dialog box	31
4.1	Steps of implementation of PLCduino	33
4.2	Pneumatic diagram using Fluidsim	33
4.3	Students use PLCmicro	34

4.4	Solder board exercises	35
4.5	Controlling motor speed using PWM	36
4.6	Comparison between (a) Basic Language and (b) Ladder diagram	38
4.7	Student learning PLC and PLCduino	39
4.8	PLC Nais with FPwin Pro platform	39
4.9	Summary of feedback	40
4.10	PLCduino hardware	41
4.11	Price comparison between Arduino versus PLC Nais	42
4.12	Ladder diagram for blinking LED	43
4.13	HEX file compile	44
4.14	Arduino Library	44
4.15	Arduino schematic	45
4.16	Uploading HEX file to Proteus	46
5.1	Compact PLCduino	48
5.2	Analog input reading	49
5.3	Typical Application Diagram	50





**LIST OF SYMBOLS**

$^{\circ}\text{C}$	-	Degrees Celcius
F	-	Force
$I_L$	-	Load Current
$V_S$	-	Voltage Supply
$R_B$	-	Base Resistor
$h_{FE}$	-	Transistor Current Gain
$V_{CC}$	-	Microcontroller 5v Voltage
$c_f$	-	Fixed Cost
v	-	Volume (Number of Units Produced)
$c_v$	-	Variable Cost Per Unit
p	-	Price per Unit
A	-	Ampere
$\Omega$	-	Ohm
V	-	Voltage
Mm	-	Millimeter
M	-	Micro

**LIST OF ABBREVIATIONS**

PLC	-	Programmable Logic Controller
PIC	-	Programmable Interface Controller
KV	-	Kolej Vokasional
VDC	-	Direct Current Voltage
SPST	-	Single Pole Single Throw
SPDT	-	Single Pole Double Throw
RM	-	Ringgit Malaysia
I/O	-	Inputs / Outputs
AC	-	Actuating Current
DC	-	Direct Current
V	-	Voltage
F	-	Farad
CPU	-	Central Processing Unit
RAM	-	Random Access Memory
ROM	-	Read Only Memory
GND	-	Ground
ILP	-	Institut Latihan Perindustrian

**LIST OF APPENDICES**

<b>APPENDIX</b>	<b>TITLE</b>	<b>PAGE</b>
A	Survey 1 Documentation	54
B	Survey 2 Documentation	56
C	Training kit development	61



**PTTA UTHM**  
PERPUSTAKAAN TUNKU TUN AMINAH

## CHAPTER 1

### INTRODUCTION

#### 1.1 Project overview

A Programmable Logic Controller (PLC) is a digital computer used in automation industries such as controlling of machineries on factory assembly line. PLC is designed for multiple input/output arrangements and has been gaining popularity on the factory floor and will probably remain predominant for some time in future. Most of this is because of the PLCs can offer an effective solution in term of cost, flexibility, and reliability. A small PLC has a fixed number of connections build in for input and output. It can be expanded further if the base model does not have sufficient I/O. The PLC programs are typically written in a special application called Ladder Diagram that can be downloaded from a personal computer or PLC console. The PLC can be reprogrammed for several times, thus make it adaptable to the process that required changes by the end user/company [19].

In line with vocational training institute objective of producing semi-professional workforce in technical field, trade and hospitality, the teaching process and practical skills become one of the important elements towards achieving the objective. In accordance to that, equipment and trainers should be able to deliver the practical aspects and they become a necessity. The role of PLC-programming in automation engineering education in vocational training institute is quite significant.

Engineering students should receive hands-on experience with PLC devices as a component in instrumentation courses. Understanding of control and PLC principles is anticipated to provide more job opportunities and good performance for engineering graduates [5].

Despite their frequent application, existing equipment only use toggle switch as the input module where it is not suitable for practical aspect and the output module only show light displays. Adding more I / O module would make the PLC training kit looks more bulky, it may just suitable for the usage in lab atmosphere and not suitable for small class room. This development of PLC Kit trainer also will focus more on students taking Programmable Logic Controller course that are offered in other programmes such as Programmable Logic Controller module in collage vocational (KV), other modules that include the teaching of PLC are Industrial Automation, Instrumentation & Control module that are offered in Vocational Training Institute (ILP).

## 1.2 Problem statement

Although student prefer to use PLC as a controller, the cost to purchase the PLC is more expensive compared to the PIC. For example as comparison; PLC from Nais with 32 I / O is cost about RM1070 while the PIC module with the same I / O is only cost about RM100. PLC also have very limited input and output, thus the limitation of instruction and direction given to it. PLCs typically use 16-bit signed binary processors. The PLC has only 16 input and output ports that makes it very limited to certain processes. With this limitation, the PLC is at a disadvantage when it comes to budget. This is because PLC needs to be added if the current amount of PLC cannot store as much information, input or output port as it should for the machine to operate. Price of 1 unit PLC expansion usually equals the price of a primary PLC.

Previous scientific studies conducted are still focused on increasing the input and output of a PLC by adding PIC as output and input devices. Interfacing PIC and PLC and this is still a big issue and should be improved. Things like discrete signals sent to PLC with voltage of 24VDC I / O, while PIC only needs 5VDC I / O. With different activation voltages, both PLC and PIC must interact and able to send and

receive data from each other. The major problem faced by student when the situation require a microcontroller to control the system is spend too much time on program development process. Based on common microcontroller in the market such as PIC, a complete and successful compiled source code is necessary to operate the PIC. Normally, most of the time is spend on writing the source code.

### **1.3 Project objective**

The aim of this project is to develop a portable and cost effective PLCduino training kit and the specific objectives are:

- i. To construct portable PLCduino training kit hardware with complete input/output peripherals.
- ii. To develop software (LDuino) that automatically convert PLC instruction list to its equivalent in Arduino language.
- iii. To evaluate the performance of the propose system technically and physically.

### **1.4 Project scope**

The scopes of this projects are:

- i. Using Arduino Uno as the controller.
- ii. Visual Basic as the software development tool.
- iii. Limited to the basic PLC input/output peripheral such as push button, lamp, and simple pneumatic system.

## 1.5 Project report layout

This project report is organized as follows;

- i) Chapter 1 briefs the overall background of the study. A quick glimpse of study touched in first sub-topic. The heart of study such as problem statement, project objective, project scope and project report layout is present well through this chapter.
- ii) Chapter 2 covers the literature review of previous case study based on PLCmicro controller background and development. Besides, general information about PLC and PIC control system also described in this chapter.
- iii) Chapter 3 presents the methodology used to design PLCduino controller and applied to the automation system. All the components that have been used in designing of PLCduino controller are described well in this chapter.
- iv) Chapter 4 reports and discuss on the results obtained based on the problem statements as mentioned in the first chapter. The results from digital prototyping using Protues software until the development of physical prototyping with hardware function will be analyzed and recorded.
- v) Chapter 5 will go through about the conclusion and recommendation for future study. References cited and supporting appendices are given at the end of this project report while the documentation CD also available and attached on the back cover of this project report for future reference.

## CHAPTER 2

### LITERATURE REVIEW

#### 2.1 Programmable Logic Controller (PLC)

Programmable logic controllers are a common solution to automation and control projects for engineers. Programmable Logic Controller was invented to replace relay control systems. More improvements to PLC occurred in the 1970's and 1980's. In the 70's, the ability to communicate between PLC was added. This also made it possible to have the controlling circuit quite a ways away from the machine it was controlling. While in the 1980's, the size of PLCs was reduced to use space more efficiently.

A PLC generally does three basic things: check the inputs, run through the program, and change the outputs. It then loops back to the top and starts again. It is fundamentally a relay control systems that is combine into a package. This means that a PLC is consist of:

- i. Input and output relays: send and receive information from the outside world.
- ii. Counters: how fast the PLC counters the information.
- iii. Timers: how long the output stays changed once the input is provided.
- iv. Data storage registers: save data after programming.



PLCs are very good for controlling outputs depending on inputs. They are remarkably robust, and able to stand all sorts of difficult conditions, such as extreme temperatures or dust in the air. It can withstand 0°C to 60°C during operating. They do not have contacts that wear out. They also can switch fairly quickly without heating up much, in direct contrast to relays. This means that cooling costs are decreased. Advantages of PLC;

- 1) Easily programmed (e.g., ladder diagram)
- 2) The system is fast and easy wiring.
- 3) The construction brief, the maintenance is simple and high reliability.

## 2.2 Programmable Interface Controller (PIC)

Microcontroller has gained its popularity among control systems builders due to its size, cost and the performance of the microcontroller which is way better compared to the existed control system. A microcontroller is the combination of a microprocessor, memory, input and output ports and some of the special functions like timer, analogue to digital converter, mathematics processor and PWM generator in one chip. A microcontroller will take an input from a device it is controlling hence controls the device by sending signals to different components in the device. Due to the availability of a number of resources such as multiple input-output, timers, serial interface and others, the microcontroller is today used for number of front end applications and standalone systems. It is now tradition to convert analog and digital circuits to microcontroller based system because of the additional advantages provided by the microcontroller, such as:

- i. Ability and ease of computation.
- ii. Relatively small size.
- iii. Reasonable cost.

Their temperature properties depend on the manufacturer. Normally they can withstand temperature from 0°C to 80°C during operating. [Dole N.E, 2003]

### 2.3 Difference between PLC and PIC

Based on general review on PIC and PLC, their different properties can be simplified into Table 2.3.

Table 2.1: Comparison between PIC and PLC

Properties	PIC	PLC
Cost	Cheap	Expensive
Size	Smaller	Bulky
Board Area	Can be reduced	Need large area compare to PIC
Handle Complex	Easier	Difficult
Programming	Changing the program requires skill programmer	Easy to change programmed
Can choose any i/o as output	Yes	No
Required Voltage	5V	24V

### 2.4 Microcontroller as PLC

A microcontroller is basically a PLC on a single chip. It contains on one chip a processor and all the supporting circuits to enable it to communicate and interface with external equipment. The programmed to produce the required control function is developed and loaded into the chip. The chip is then embedded in a machine or device to control it. A microcontroller would need a suitable circuit built around it to work like a PLC. Because it runs off of a low DC voltage, usually around 5VDC and it has inputs and outputs which are usually TTL (some pins are open collector). In other word we can said A Programmable Logic Controller (PLC) is a microcontroller-based, general-purpose electronic device to control the operation of a

machine or process. Contrary to conventional microcontroller based systems, PLCs are not programmed by the device manufacturer but by the machine builder or the end user.

## **2.5 Previous Case Study**

Many previous studies carried out in order to reduce construction costs and ease the use of PLC. A thorough literature overview was done on the usage of PLC in education and industry. From this previous studies, the development of PLC training kit can be divided into four main categories which are;

- i. Software simulator kit
- ii. Real PLC training kit
- iii. Micro controller as a PLC training kit
- iv. Combination PLC with micro controller

### **2.5.1 Software simulator kit**

Interactive learning is one of the effective methods of teaching where student involved in hand-on activities besides learning theory alone. Therefore a thorough literature overview was done on the usage of virtual simulation software training kit.

Norashikin M. and Mohd Mukhlis (2011) introduce a PLC Integrated Development Environment (IDE) tool suit which is developed to assist students' learning in the class. It consists of ladder diagram editor, simulator and compiler. This software package is developed using Object Oriented Programming (OOP) language Visual Basic 6 to create a virtual microcontrollerenvironment in simulation process.

Luo Wenhua and Li Na (2010) introduces an education simulation system built on Programmable Logic Controllers (PLC). The structure and the function of the system is designed and realized according to the basic features of the PLC industrial control system, combining the information of the technique requirement

and the equipment condition in a practical cement production control, etc. The article emphatically discusses the organization, implementation and adaptability of the equipment simulation subsystem and explains the essential designing principles of the equipment simulation, combined with the rotary kiln which is an important equipment in the cement production.

Matti, Jussi and Juha Katajisto (2010) developed a virtual learning environment, in particular for PLC programming. In the learning environment, programming is done by using standard PLC programming application (Beckhoff TwinCAT). Programming environment include virtual models of a robotic cells, a conveyor system, a train track and a house. In this paper has been described especially house automation model, its structure and function. The model house is built by open source graphics engine (Ogre).

However, virtual simulation PLC does not reflect the actual working order. Another disadvantage user are not exposed to good wiring methods and do not have the skills to troubleshoot PLC. A hardware or training kit should be developed as well as the communication protocol with the PLC IDE to provide the students with the online simulation and real application.

### **2.5.2 Real PLC training kit**

Programmable Logic Controller (PLC) Kit for teaching and learning is developed based on the PLC trainer board which is embedded with I/O module such as normally open push button, 24VDC motor, 24VDC relay, 24VDC solenoid valve and 24VDC lamp.

I. Burhan and A. Azman (2012) developed a PLC training kit to help the students to achieve the objective and learning outcome in enhancing the hands on skill aspect through circuit designing, installation and trouble shooting. The development of PLC Kit has been designed and improved by increasing the number of input and output components, cost reduction and also it is user friendly whereby the three separate modules are attached to this PLC Kit. This PLC Kit also can be interfaced to other various types of PLC controller such as Omron, Siemens and Panasonic (NAIS).



Figure 2.1: Overall view of PLC Kit

Zarizal Bin Eddy (2008) developed a model of traffic light system by the application of PLC. This model is integrated with PLC Keyence KV series. It uses three PLC which every PLC have ten input and six output. For this model it uses two input and eighteen output. It have start button to start operating the system and stop button to terminate the operation of the system. This application is come from the sequence that been program in PLC by ladder diagram.

A F Kheiralla, (2007). He has successfully designed and developed a low cost programmable logic controller (PLC) workbench for educational purposes. The developed bench, hardware consist of PLC (Siemens, STEP7-224XP) unit, 24V/10A DC (CE, DP177.101) power supply, personal computer, USB/PPI multi-master cable, three DIN Rail, ten pieces of 24 VDC relays, thirty jacks, thirty sockets. The selected PLC unit has two communication ports, fourteen inputs and ten outputs discreet plus two inputs and one output analog. Laboratory activities of the PLC workbench includes five developed modules namely replacing relays by PLC, (AND/OR/NOT) functions, latching, timer, and counter as well as packing system prototype. A Ladder diagram under Micro/Win32 software is used to run the workbench. The unit total cost is about 1600 US Dollars.



Figure 2.2: Overview of PLC Workbench

Mohd Shafiz Bin Said (2007) design and implement of real time four junction traffic light using PLC with monitoring system and car movement. This system used PLC Omron as a controller. This paper has no much differ from research done by Zarizal Bin Eddy (2008).

Ahmad Fairuz Muhd Amin, Mohd Ariff Mat Hanafiah, Marizan Sulaiman (2005) discussed on how problem-based learning can be used to enhance the students' learning experience in programmable logic controller. Also they use individual set of PLC to its function such as input/output relay or temperature control for student project and it is not maximise the usability of PLC equipment's which can be shared through a networking capability or in a distributed system. The course requires practical skills to complete the laboratory assignments, which give students hands-on experience. Although every phase of developing the practical skills is important, they have found that hands-on experience in applying ladder diagram using software tool to solve problems present the presents the greatest challenges in a laboratory environment. The purpose of implementing PBL is to motivate the student to integrate and utilize knowledge rather than to re-involve the student into the learning process after an extended period of inactive listening.

With real PLC training kit it is obvious that the students will benefit what they have learnt based on projects and understand the design and implementation of PLC which currently being used in industries. But the major obstacles to teaching



Programmable Logic Controller (PLC) is a variety of PLCs and the rapid pace of technological development with new models and innovations. Moreover, costs incurred in the setting up of comprehensive and modern PLC laboratory facilities, and in the required periodic updating of teaching material and equipment are, as a result, very high.

### 2.5.3 Micro controller as a PLC training kit

PLC are well known controller to control an automation system. However, the cost of PLC is expensive for small automation system and its size can be considered large as a controller. To overcome this problem, there is a new thought to use Programmable Interface Controller (PIC) which is smaller and cheaper to replace PLC.

Dr Wesley B. Williams P.E et al. (2013) develop a model to reduce the cost of learning PLC by proposing I-Trilogy and LabVIEW combine with Arduino. From the assessment he found;

- (i) Students felt more comfortable with ladder logic than LabVIEW or Arduino.
- (ii) Students also felt as though they would likely come across ladder logic and PLCs in the careers after graduation.
- (iii) Student did feel that Arduino would be something that they would revisit on their own as a low cost way to experiment with electronics, programming, and automation.

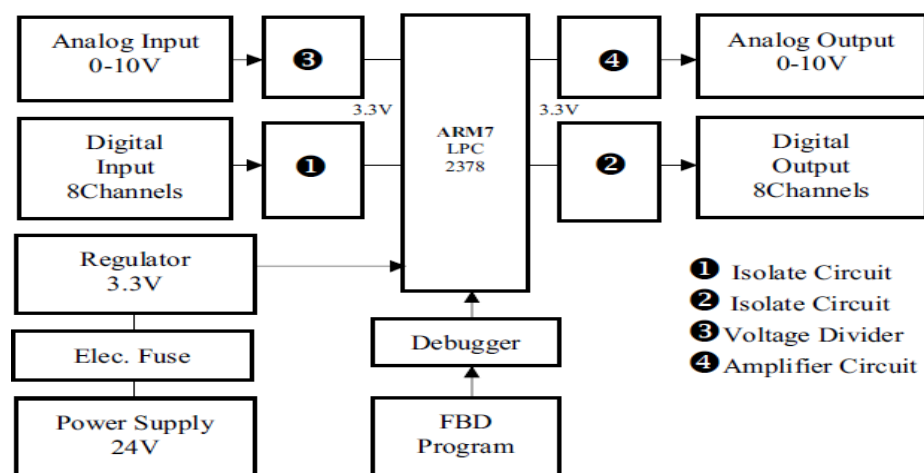

Figure 2.3: The architecture of an embedded PLC

Pornjit Pratumswan and Watcharin Pongaen (2011) proposed the seamless combination of the LabVIEW software and the ARM Microcontroller with the LabVIEW embedded module. They use the FBD programming language for control of embedded PLC because the LabVIEW Embedded Module for ARM Microcontrollers is a comprehensive graphical development environment for embedded design. The flexibility of the proposed PLC makes it relatively easy and less costly to teach the basic principle of different kinds of PLCs due to their variety and rapid change. The implementation of the embedded PLC is discussed and evaluated. The results of evaluation shows that embedded PLC can be taught in an uncomplicated manner.

Mohammad Safuan Bin Sheafi (2010). This project will mainly concerned on controlling the sequence of the three linear double-acting cylinder actuator movements by using microcontroller PIC 18F452 coupled with pneumatic solenoid valve. This microcontroller is used for controlling predefined sequences of opening and closing of solenoid valves that will activate the actuator. A program in MikroC PRO is written and developed to communicate with the microcontroller as to move the actuator according to plan sequences.

Zaimi Bin Ahmad (2005). The objective of this project is to design a traffic light microcontroller that operates based on the current traffic flow. Traffic flows are classified into three conditions that are low level, medium level and high level. This condition will be decided when the traffic light is in stop condition (red light). This traffic light microcontroller is designed using peripheral interface controller (PIC). Then, the program is written using Microcode Studio software equips with PIC Basic Pro Language before it is downloaded into PIC. The advantage of using PIC microcontroller is it can reduce the cost of controlling the traffic light.

Jiang Hai Huang, et al. (2003) have developed a new type of PLC. This type of PLC is in low cost and with a good performance. At the same time, they developed an Integrated Development Environment (IDE) for the PLC. They used C8051F, as a processor for PLC. C8051F is a high-speed SOSI-compatible microcontroller. And it is integrated with enough interfaces. This character of C8051F simplified the hardware structure of PLC. And, the IDE is based on the PLC Programming Language Standard IEC6113-3, supporting multi-language and graphic drive.



By using microcontroller to replace PLC will defiantly reduce the cost of controller, but in practical the cost of interfacing input and output component will be increase. It's because microcontroller use 5V as an input and output source. Most PLC input and output component (such as relay, sensor, etc.) use 24V as a power source. The major problem faced by designer when the situation require a microcontroller to control the system is spend too much time on program development process. Based on common microcontroller in the market such as PIC (Programmable Interrupt Controller), a complete and successful compiled source code is necessary to operate the PIC. Normally, most of the time is spend on writing the source code.

#### **2.5.4 Combination PLC with micro controller**

In this method it involves two important control systems; One is Programmable Logic Controller (PLC) and the other is the Programmable Integrated Circuit (PIC). These two systems have different behaviours and programming techniques. Both hardware and software are complimented to each other it in terms of design and written programme.

Nurulafiza Bt Ramli (2009) develop an electronic board which detect signal from Omron PLC trainer. The signals from programmable logic circuit were transferred to PCB board as a time clock signal. PIC 16F877A microcontroller was used as interface in order to display time clock on LCD display. The electronic board also was designed with the voltage regulator to step down the voltage, 24V form PLC to 5V. The software development started with the flow chart, ladder diagram for PLC and finally, the software was written in C language and implement on the PIC. As the result, whenever the PLC counting and change the signal (clock), the LCD display will show the output simultaneously with the PLC.

Chong Kok Hee (2009) used a microcontroller to expand the inputs / outputs of the PLC OMRON CJ1GCPU42H. This project was developed with the main objective to expand the inputs / outputs for PLC inexpensively using PIC while maintaining standard PLC input properties and functionality. In this project, 3 inputs / outputs from the PLC will be use to expand the PLC outputs and the total outputs

for PLC will become 20 outputs after the modification is done. The combination of PIC 16F877A and external relay are needed in order to expand the input / output from PLC. Besides that, some of the programming languages such as CX – programming and C language will be use in the project, where CX – programming will be use in PLC and C language will be use in PIC.

Ng Boon Ping (2009) develop a road traffic system Programmable Logic Controller (PLC) training kit which will implement road traffic monitoring via MMI as well as controlling by PLC or manually control in real time. The MMI can interrupt the traffic lights sequence using manually controlled. A MMI which let user to decide the number of cars appeared in each of the four junctions and road traffic animation is developed using Visual basic 6.0. Besides, a database is created so that the number of cars appeared and passed can be recorded per minute. Microcontroller PIC 18f452 in the interface board allowed the communication to take place between PLC and the MMI.

Siti Fatimah Binti Sulaiman (2009) designed an adapter to interface between Programmable Logic Controllers (PLC) OMRON and pneumatics trainer; where several applications are also adapted in this project. Besides that, the ladder diagram is designed and simulated using CX-Programmer software in order to ensure the output produced at pneumatics trainer is same as the simulation. The adapter will be able to receive a 24V input from the PLC trainer. It will then process the input into either a 24V pneumatics trainer or a 5V PIC. This project also prove that interfacing of PLC and PIC can be done.

W.M.Fahmi (2009). This project used 125 kHz RFID system including RFID tag, RFID reader, PIC microcontroller 16f788A and also PLC OMRON CPM 2a. In this project, programming language of visual basic 6 was developed to design the system interface. The system interface was connected by Microsoft Access database to store the registration information.

Abdullah Helmee (2008) develop an expansion of PLC input port using the microcontroller. It involves two important control systems; One is a Programmable Logic Controller (PLC) and the other is the Programmable Integrated Circuit (PIC). This project shows how the two control systems are interfaced and thus increasing the input port of the PLC. Both hardware and software are complimented to each other it in terms of design and written programme.

Mohd Shahrin (2008) develop an expansion of PLC output port using the microcontroller. In this project, the controller are able to handle more outputs correctly using the PIC without adding more PLC ports which are costly. It used Omron PLC as a controller and CX Programmer as a programming software.

PLC has very limited numbers of input and output. Thus the limitation of instruction and direction given to it. PLCs typically use 16-bit signed binary processors. Some PLC has only 16 input and output ports that makes it very limited to certain processes. The problem occurs when input and output ports need to be added for it to receive and produce more output as more instructions are given. Interfacing PLC and PIC needs a lot of things to figure out. Things like discrete signals sent to PLC with voltage of 24 VDC I/O, while PIC only needs 5 VDC I/O. With different activation voltages, both PLC and PIC must interact and able to send and receive data from each other. Most of the method above are focus on the interface between PLC and PIC because they will affect the entire cost of the project by choosing the components.

Based on those related work, the researchers make a great efforts to propose the cheaper and good controller in the industrial. From these categories, micro PLC is capable to control the trade-off between price constraint and real hands on device. Thus, further investigation of this controller is needed in depth.



## CHAPTER 3

### METHODOLOGY

#### 3.1 Introduction

In this chapter, the explanation will be roughly about how to setup the project. It will be start with the approach that will be used. Then follow up by development phases, tools and techniques, PLCduino versus other controller. The process flow and design requirement for this project will be explain in this chapter.

The constraint on this methodology are that it must support the sub-disciplines of software engineering, computer programming and panel wiring. While the basic system must support digital I/O it should be expandable to support analog handling. The detailed objectives being that it must:

- Be safe
- Be low cost
- Interfaces to a PC
- Incorporate an industrial standard PLC
- Support the IEC 6-1131 programming languages
- Interface with common industrial electrical components
- Be able to translate engineering ideas from theoretical description to practical tutorials.

## 3.2 Experimental phase

In this experiment I have develop a PLC system using PIC16F877A. LDmicro are used to write and simulate ladder logic program. When is ladder logic program is successfully compile, we need to upload it into PIC processor. As a result, this experiment shows that ladder diagram can be integrated with microcontroller.

### 3.2.1 Hardware development

In this testing unit, I have write a very simple program. I am assuming that the user have written ladder logic before, and that they have some basic familiarity with microcontrollers, but that have never used LDmicro.

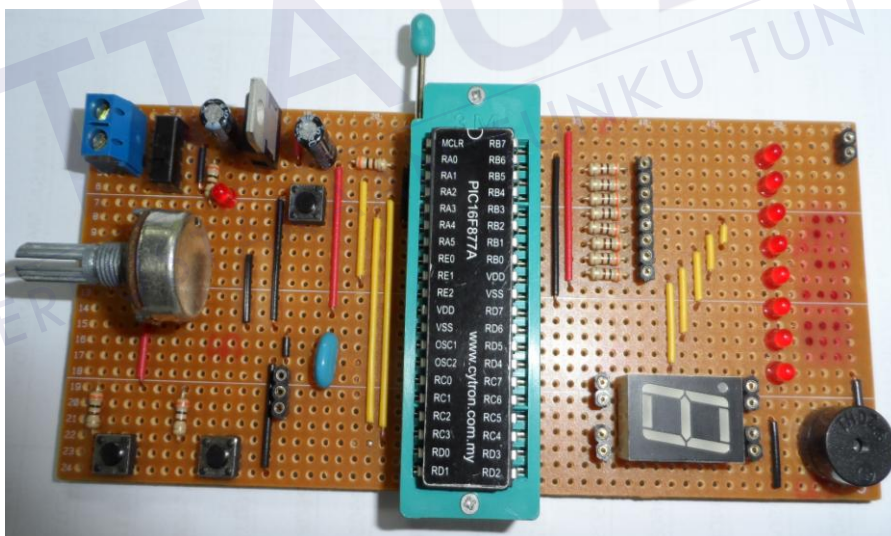

Figure 3.1: Hardware development

The hardware device will have a few pushbutton, and LEDs. At startup, the LED will be off. When user press the pushbutton once, the LED will turn steady on. The second time the user press the pushbutton, the LED will start blinking. The third time that user press the button, the LED will turn off again. On subsequent presses, the cycle will repeat.

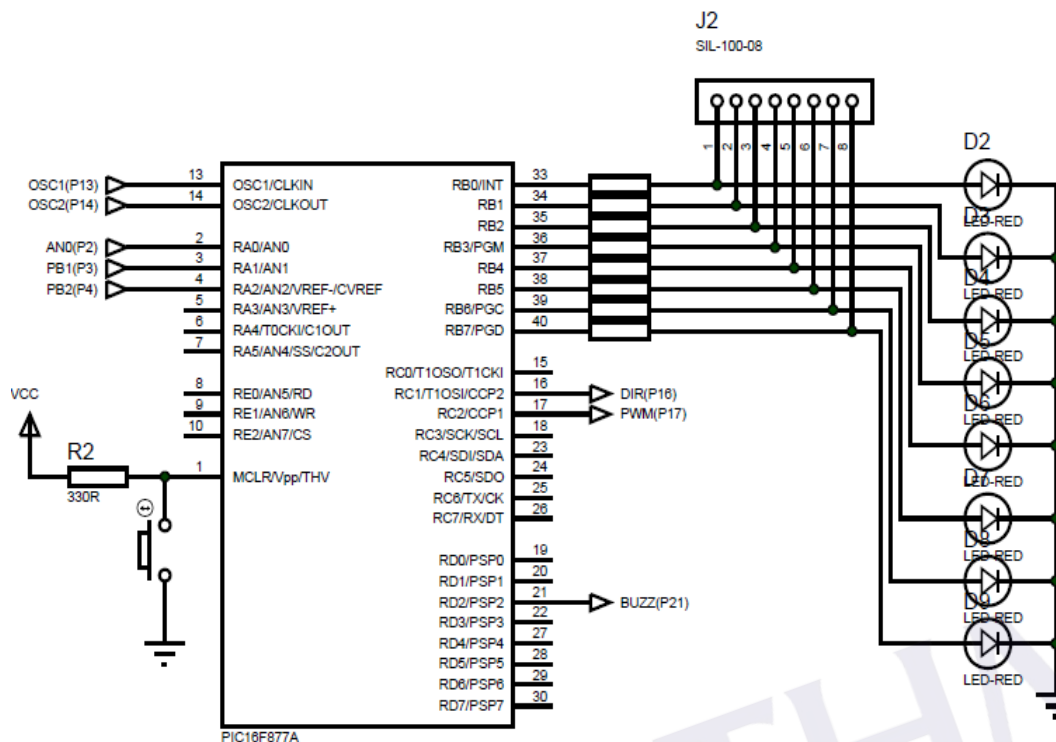

Figure 3.2: Microcontroller Selection and Schematic

I'm using a PIC16F877A as a processor. Input push button goes to VDD, and there is a pull-down. In LDmicro software, pull-down circuit are equivalent to normally open contact stated in Ladder diagram.

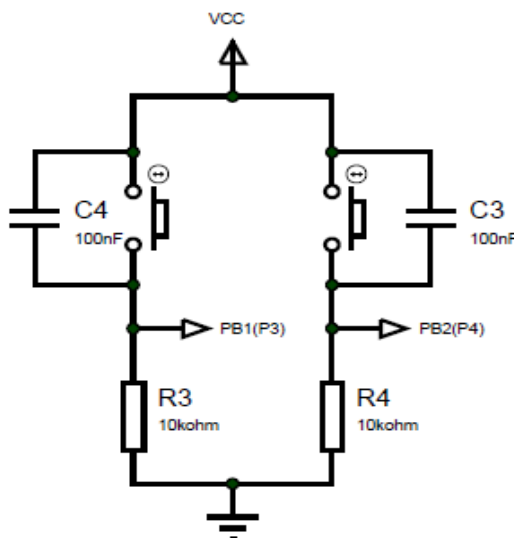

Figure 3.3: Pull down / active high circuit

### 3.2.2 Software testing

After completing fabricate circuit, we need to draw ladder diagram in LDmicro. The program will have three states: off, steady on, and blinking. The program should change its state on each rising edge of the signal from the pushbutton. Where `state 0` is `off`, `state 1` is `steady on`, and `state 2` is `blinking.` The counter counts 0, 1, 2, 0, 1, 2, ..., continuously.

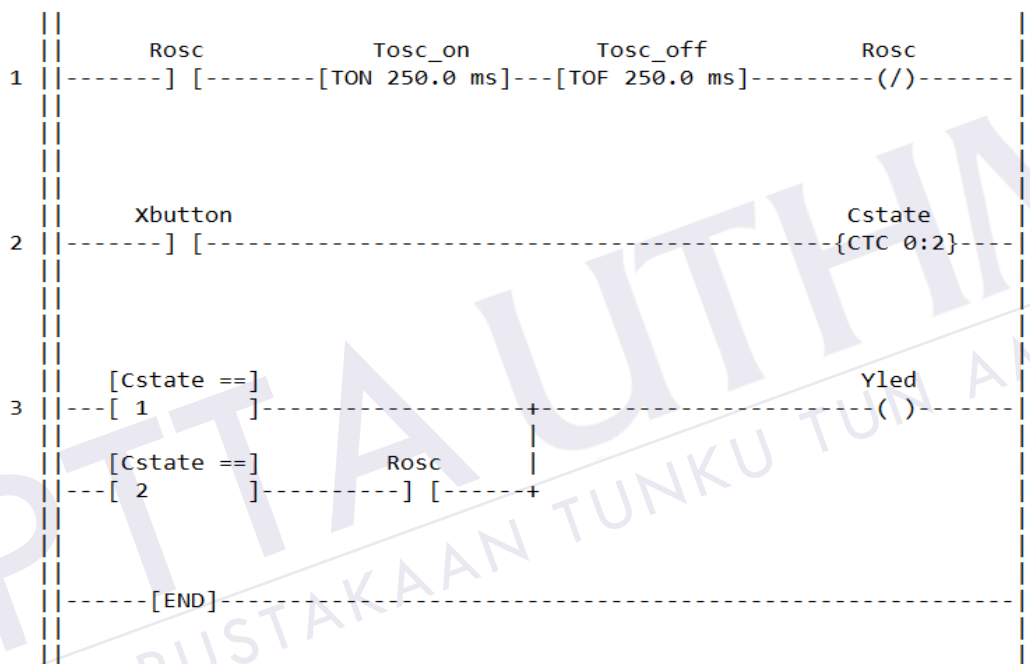

Figure 3.4: Ladder diagram for blinking Led using LDmicro

If ladder diagram programming compile without error it's ready to simulate. Choose Simulate and then choose Simulation Mode. The display will change; the ladder diagram will appear mostly greyed, but user won't see anything changing with time. That is because the PLC is not yet cycling. To start it cycling, choose Simulate - Start Real - Time Simulation. Now user will see things happening: the oscillator is obviously running, but the LED ('Yled') is still off, which is what experiment want, because no one has pressed the button yet. To simulate pressing the button, double-click the text 'Xbutton' in the list at the bottom of the screen. You have now simulated bringing the pushbutton input high; this is what would happen if someone depressed (but did not yet release) the pushbutton.



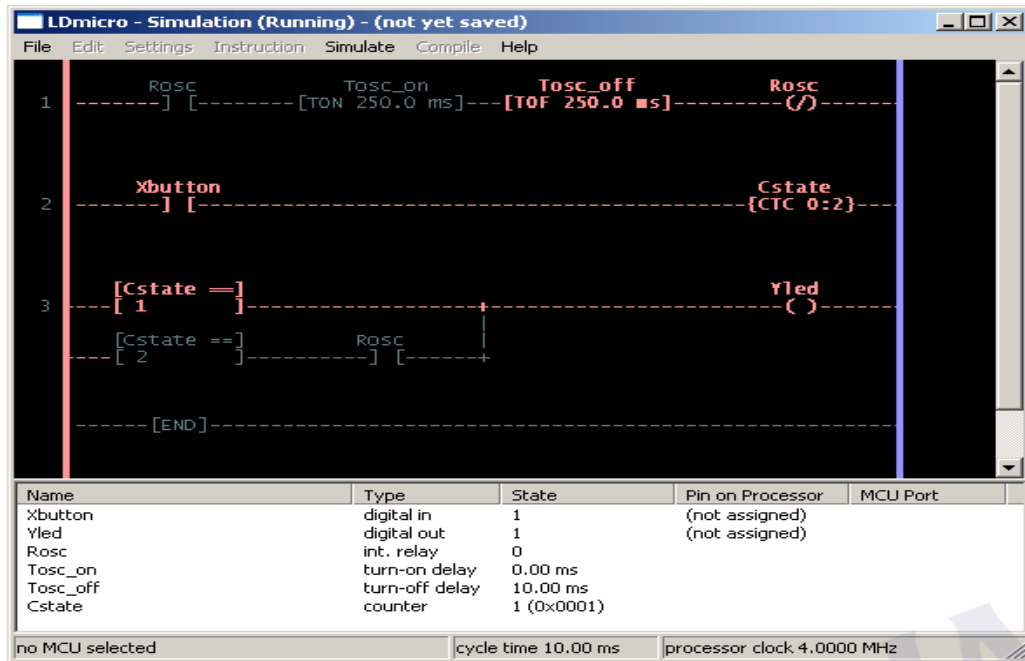

Figure 3.5: Simulating the Program

So now user are fairly sure that the program works. At this point we are ready to generate actual code, and try it in the micro. But before compiling to an IHEX file user need to assign pins for inputs and outputs.

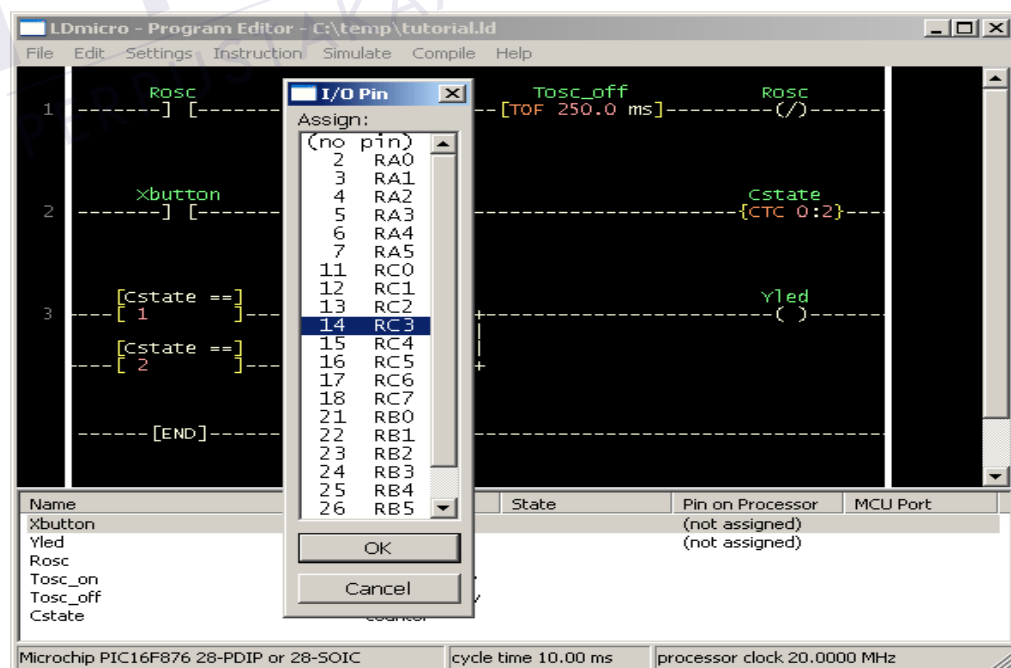

Figure 3.6: Assign pin for Input and Output



After completed the pin assignment, user need to compile and specify where they want to put the IHEX file. Then use PICKit2 IDE to load the IHEX file into your device.

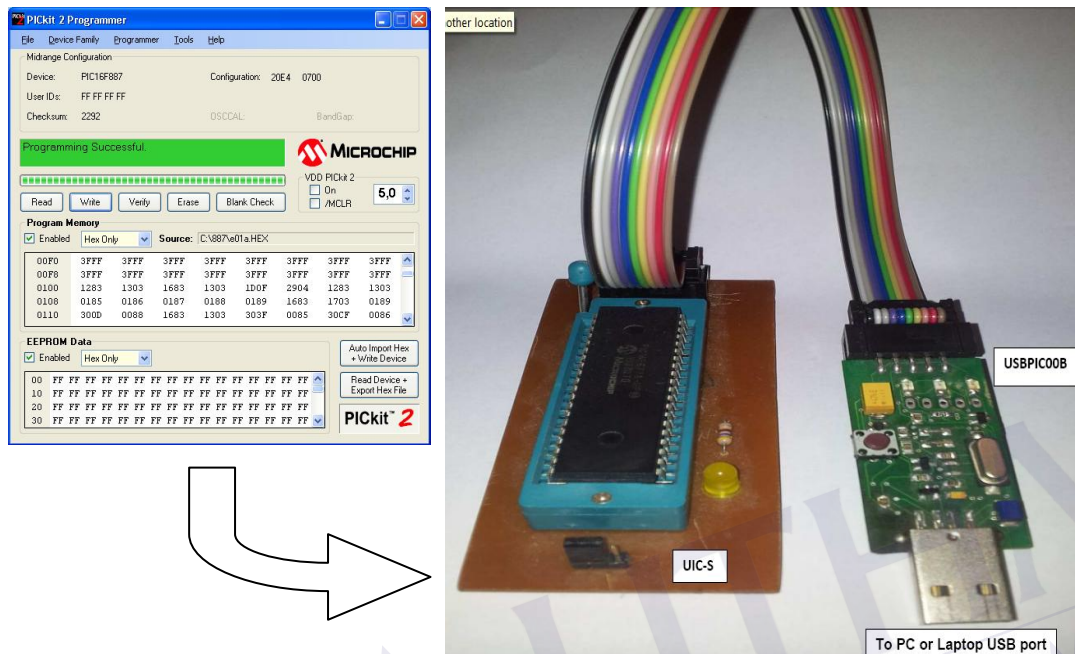

Figure 3.7: Uploading IHEX file into PIC16F877A

LDmicro also offers specialized instructions, for things like arithmetic, analog (A/D) inputs, PWM, and even text output to a character-based LCD.

### 3.3 Hardware design

We select to use the Arduino Uno microcontroller to develop PLCduino because it is widely used across many controller designs due to;

1. It is an open-source project, software/hardware is extremely accessible and very flexible to be customized and extended.
2. It is flexible, offers a variety of digital and analog inputs, SPI and serial interface and digital and PWM outputs.

3. It is easy to use, connects to computer via USB and communicates using standard serial protocol, runs in standalone mode and as interface connected to PC/Macintosh computers.
4. It is inexpensive, around RM70 per board and comes with free authoring software.
5. Arduino is backed up by a growing online community, lots of source code is already available and we can share and post our examples for others to use, too!

With this capability, a large portion of the application could be developed and tested before the hardware design is complete.

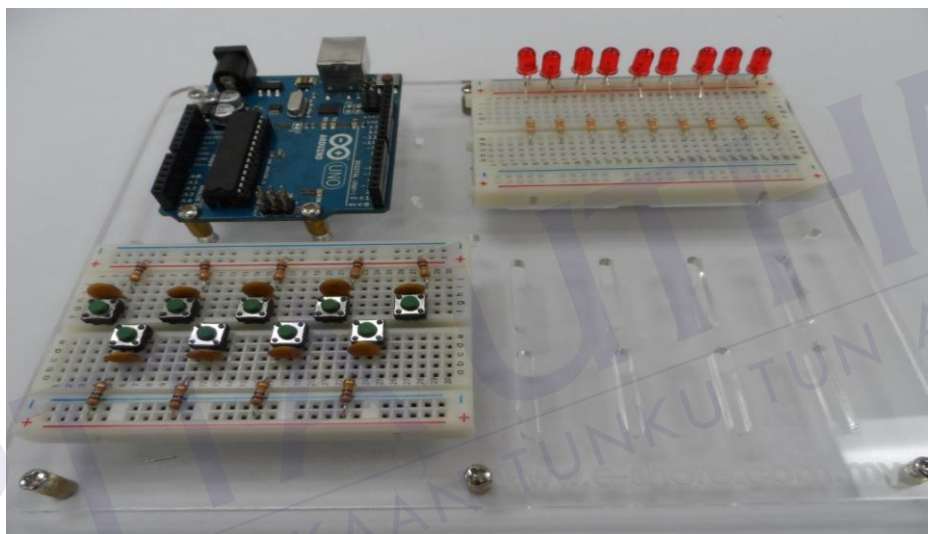

Figure 3.8 The main component's used in development.

Table 3.1 Specifications & Features of PLCduino

Feature	Arduino Uno
Microcontroller	ATmega328
Digital I/O Pins	18 (9 input / 9 output)
Operating Voltage	5V
DC Current per I/O Pin	40 mA
Flash Memory	32 KB (ATmega328)
Serial Port	USB 2.0

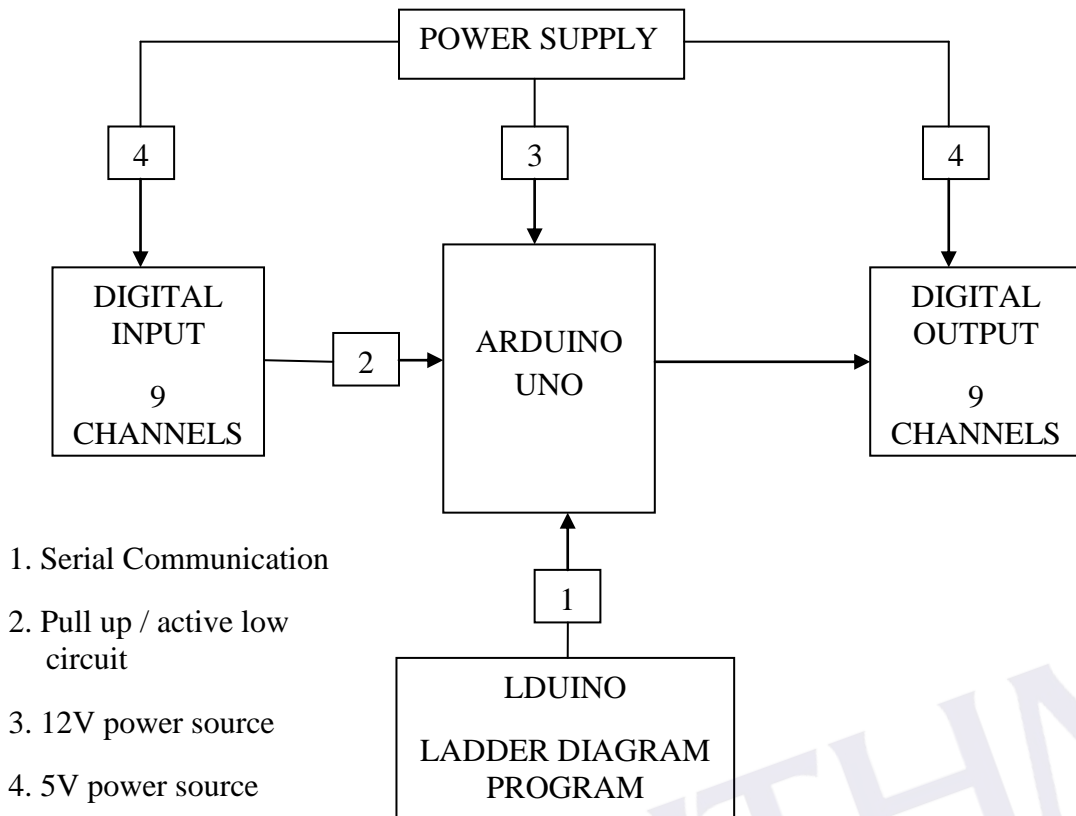

Figure 3.9 The architecture of PLCduino.

1) Digital input: Most equipment to be connected to digital inputs use 24VDC such as switches, proximity sensor etc., therefore they require a circuit to isolate and reduce the signal. Figure 3.10 shows the external circuit of the digital input.

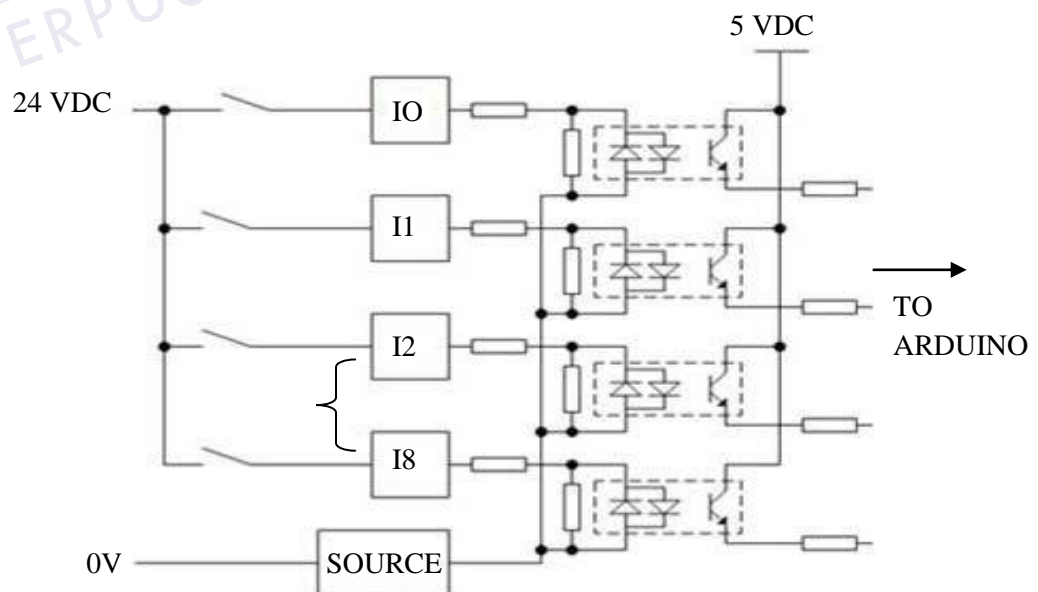

Figure 3.10 External circuit of digital input

## REFERENCES

Jianghai Huang, Yu-Cheng Li, Wi Luo, Xiao-Xia Liu, Kui-Feng Nan, The Design Of New-Type PLC Based On IEC61131-3. *Proceeding of the Second International Conference on Machine Learning and Cybernetics*, Xi'an, 2-5 November 2003.

Zaimi Bin Ahmad (March 2005). Designing A Traffic Light Controller Using PIC 16F877. Thesis (*Kolej Universiti Teknikal Kebangsaan Malaysia*).

Ahmad Fairuz Muhd Amin, Mohd Ariff Mat Hanafiah, Marizan Sulaiman. Problem Based Learning Approach in Programmable Logic Controller. *Proceedings of Regional Conference on Engineering Education*, December 12-13, 2005, Johor, Malaysia.

Mohd Shafiz Bin Said (May 2007). Design and Implementation of Real Time Four Junction Traffic Light Monitoring System Using PLC. Thesis (*University Technical Malaysia Malacca*).

A F Kheiralla, Osama Siddig, Ahmed A Elhaj Mokhtar, Montasir Esameldeen, (July 2007). Design and Development of a Low Cost Programmable Logic Controller Workbench for Education Purposes. *International Conference on Engineering Education – ICEE 2007*.

Mohd Shahrin Bin Darmin (May 2008). Inexpensive PLC Output Port Expansion Using Microcontroller. Thesis (*University Technical Malaysia Malacca*).

Abdullah Helmee B. Hj. Suki (May 2008). Inexpensive PLC Input Port Expansion Using Microcontroller. Thesis (*University Technical Malaysia Malacca*).

Zarizal Bin Eddy (May 2008). A Model of Traffic Light System by the Application of PLC. Thesis (*University Technical Malaysia Malacca*).

W.M.Fahmi Fathuddin B. Wan Mokhtar (May 2009). Smart Office Using RFID via PIC and PLC. Thesis (*University Technology Malaysia*).

Siti Fatimah Binti Sulaiman (April 2009). PLC's Interface between Pneumatics and PIC With Several Applications. Thesis (*University Technical Malaysia Malacca*).

Ng Boon Ping (May 2009). PLC Based Real Time Controlling And Monitoring Virtual Road Traffic. Thesis (*University Technology Malaysia*).

Chong Kok Hee (April 2009). Expansion of Input / Output PLC Omron CJ1GCPU42H Using PIC. Thesis (*University Technical Malaysia Malacca*).

Nurulafiza Bt Ramli (April 2009). An Electronic Clock Display Using Omron PLC Trainer And PIC 16F877A. Thesis (*University Technical Malaysia Malacca*).

Matti Vaananen, Jussi Horelli. Virtual Learning Environment Concept for PLC-programming. 2010 *2nd International Conference on Education Technology and Computer (ICETC)*.

Luo Wenhua, LiNa. Designing and Implementation of Education Simulation System Base on PLC. 2010 *2nd International Conference on Computer Engineering and Technology*.

Mohammad Safuan Bin Sheafi (Dec 2010). Application of Microcontroller to Control Pneumatic Actuator. Thesis (*University Malaysia Pahang*).

Norashikin M. Thamrin, Mohd. Mukhlis Ismail. Development of Virtual Machine for Programmable Logic Controller (PLC) by Using STEPS™ Programming Method. 2011 *IEEE International Conference on System Engineering and Technology (ICSET)*.

Pornjit Pratumswan and Watcharin Pongaen. An Embedded PLC Development for Teaching in Mechatronics Education. 2011 6th *IEEE Conference on Industrial Electronics and Applications*.

Burhan, I., Talib, S. dan Azman, A.A. (March 2012). Design and Fabrication of Programmable Logic Controller Kit with Multiple Output Module for Teaching and Learning Purposes. 2012 *IEEE 8th International Colloquium on Signal Processing and its Applications*.

Dr. Wesley B. Williams P.E (June 2013). LabVIEW and Arduino as a Gateway to PLC programming. 120th *ASEE Annual Conference & Exposition*. Paper ID #6767.

<http://www.electronics-micros.com/software-hardware/plc-lib-arduino#index>

<http://soapboxautomation.com/support-2/soapbox-snap-tutorial/soapbox-snap-arduino-tutorial/>

