

DESIGN STUDY OF OUTER ROTOR FIELD EXCITATION FLUX SWITCHING  
MOTOR FOR ELECTRIC VEHICLES

NOR HASNATI BINTI ABDULL PATAS

A project report submitted in partial fulfillment of the award of the Degree of Master of  
Electric and Electronic Engineering

Faculty of Electric and Electronic Engineering  
Universiti Tun Hussein Onn

JULY 2014

*Specially dedicated to my beloved husband, son, mother, father and brothers*



PTTA UTHM  
PERPUSTAKAAN TUNKU TUDJAHAMINAH

## ACKNOWLEDGEMENT

In the name of Allah S.W.T, the Most Gracious, the Ever Merciful Praise is to Allah, Lord of Universe and Peace and Prayers be upon His final Prophet and Messenger S.A.W.

Firstly, I would like to take this opportunity to thank the Almighty Allah for His mercy, His grace and kindness in my life as slave and His blessing given to me for the completion of my study in Universiti Tun Hussein Onn, Malaysia.

Secondly, I would take this opportunity to sincerely express my highest gratitude to my supervisor Dr Erwan Bin Sulaiman for his guidance, ideas and advice during this project.

My sincere gratitude also goes to my colleagues for their aid, ideas and advice and my lecturers and my friends who had helped me directly or indirectly.

I would like also to express my appreciation to research master's student for their help and permission to use lab and equipment needed in this project.

Finally, special thanks extended to my beloved family especially my husband Mr. Ahmad Husni Md Noor and my lovely son Muhammad Irsyad who brightened the lives of our family. A sincere thanks to my mother Mariah Mohammad and my father, Abdull Patas Jidin who had given me the moral support and prayed for my success.

## ABSTRACT

Flux switching machines (FSMs) that consist of all flux sources in the stator have been developed in recent years. They can be categorized into three groups that are Permanent magnet (PM) FSM, field excitation (FE) FSM and hybrid excitation (HE) FSM. Among these FSMs, the FEFSM offers advantages of low cost, simple construction and variables flux control capabilities suitable for various performances. In this project is design study of outer-rotor field-excitation flux switching motor (FEFSM) with a topology of 12-slot and 10-pole configuration (12S-10P) with all active parts are located on the stator for electric vehicle application as a low-cost of non-Permanent Magnet (PM) machine. The performance of the proposed motor on the initial design and improved design are analysed based on 2-D Finite element analysis (FEA). The performance of the improvement design shows that the maximum torque is obtained 118.2165 Nm which is greater than the initial design that obtained 72.788Nm, whereas the maximum power has achieved about 77.65kW.



## ABSTRAK

Mesin pensuisan Fluks (FSMS) yang terdiri daripada semua sumber fluks di pemegun telah dibangunkan sejak tahun-tahun kebelakangan ini. Iannya boleh dikategorikan kepada tiga kumpulan iaitu magnet Kekal (PM) FSM, bidang pengujian FSM (FE) dan pengujian hibrid (HE) FSM. Antara FSMS ini, bidang pengujian FSM (FE) menawarkan kelebihan kos yang lebih rendah, pembinaan yang mudah dan pembolehkan keupayaan kawalan fluks sesuai untuk pelbagai jenis aplikasi. Dalam projek ini adalah kajian reka bentuk luar-pemutar bidang-pengujian fluks beralih motor (FEFSM) dengan topologi 12-slot dan konfigurasi 10-ruang (12S-10P) dengan semua bahagian-bahagian aktif terletak di pemegun untuk aplikasi kenderaan elektrik kos rendah sebanyak Magnet bukan Tetap (PM) mesin. Prestasi motor yang dicadangkan ke atas reka bentuk awal dan reka bentuk lebih baik dianalisis berdasarkan menggunakan perisian 2-D analisis unsur terhingga (FEA). Prestasi reka bentuk peningkatan menunjukkan bahawa tork maksimum diperolehi 118.2165 Nm yang lebih besar daripada reka bentuk awal yang diperolehi 72.788Nm, manakala kuasa maksimum telah mencapai kira-kira 77.65kW.

## TABLE OF CONTENTS

<b>ACKNOWLEDGEMENTS</b>	<b>ii</b>
<b>TABLE OF CONTENTS</b>	<b>v</b>
<b>LIST OF TABLES</b>	<b>viii</b>
<b>LIST OF FIGURES</b>	<b>ix</b>
<b>LIST OF SYMBOLS AND ABBREVIATIONS</b>	<b>xiii</b>
<b>CHAPTER 1 INTRODUCTION</b>	<b>1</b>
1.1 Introduction	1
1.2 Problem Statement	2
1.3 Objectives	4
1.4 Scopes	4
<b>CHAPTER 2 LITERATURE REVIEW</b>	<b>5</b>
2.1 Background	5
2.2 Specifications of Flux Switching Machine (FSM)	5
2.3 Permanent Magnet Flux Switching Machine (PMFSM)	6
2.4 Hybrid Excitation Flux Switching Machine (HEFSM)	8
2.5 Field Excitation Flux Switching Machine (FEFSM)	9

<b>CHAPTER 3 METHODOLOGY</b>	<b>14</b>
3.1 Initial Design for 12S – 10P	17
3.1.1 Geometry Editor	15
3.1.2 JMAG Designer	24
3.2 Improvement Design for 12S-10P	29
3.3 Design parameter and procedures for improvement Of 12S-10P	32
<b>CHAPTER 4 RESULT AND PERMANCES</b>	<b>39</b>
4.1 Initial Design of 12S-10P Outer Rotor FEFSM	39
4.1.1 FEC Flux linkage at various FEC Current	42
4.1.2 Flux strengthening	43
4.1.3 Cogging torque characteristic with no load	44
4.1.4 Flux line of FEC at no load condition	44
4.1.5 Flux distribution	47
4.1.6 Torque versus $J_e$ at various $J_a$	49
4.1.7 Torque and power versus speed characteristics	50
4.2 Final improvement design for Outer rotor FEFSM	51
4.2.1 Load analysis of the final improvement design	52
4.2.2 Torque and power versus speed	54
4.2.3 Flux line flow	55
4.3 Summary of Initial and Improvement design of 12S-10P ORFEFSM	57

<b>CHAPTER 5 CONCLUSION</b>	<b>59</b>
5.1 Conclusion	59
5.2 Future Works	60
<b>REFERENCES</b>	<b>61</b>



**PTTHM**  
PERPUSTAKAAN TUNKU TUN AMINAH



**LIST OF TABLES**

3.1	The design parameter for the proposed ORFEFSM	17
3.2	Initial and final design improvement of 12S-10P FEFSM	31
4.1	Initial and final design improvement parameters of 12S-10P Outer rotor FEFSM	52



**PTTA UTHM**  
PERPUSTAKAAN TUNKU TUN AMINAH

## LIST OF FIGURES

2.1	Classification of flux switching machine (FSMs)	6
2.2	Operation principle at two typical rotor positions for outer rotor	7
2.3	Principle operation of PMFSM	8
2.4	Principle operation of ORHEFSM (a) $\theta_e = 0^\circ$ (b) $\theta_e = 180^\circ$ more excitation, (c) $\theta_e = 0^\circ$ (b) $\theta_e = 180^\circ$ less excitation	9
2.5	1-phase 8S-4P FEFSM	11
2.6	3-phase 12S-8P segmental rotor	11
2.7	3-phase 24S-10P FEFSM	12
2.8	Principle operation of FEFSM (a) $\theta_e=0^\circ$ and (b) $\theta_e=180^\circ$ flux moves from stator to rotor (c) $\theta_e=0^\circ$ and (d) $\theta_e=180^\circ$ flux moves from rotor to stator	13
3.1	Initial proposed design of Outer Rotor of 12S-10P FEFSM	15
3.2	Work flow of experiment implementation for Geometry Editor	16
3.3	Design initial parameter defined as D1 – D9	17
3.4	Sketch the rotor at the layout	18
3.5	Create a region of rotor	18
3.6	Mirror duplication of rotor and radial duplication of 10P of rotor	19
3.7	Draw a fraction of Stator	19
3.8	Create a region of Stator	20
3.9	Mirror duplication of Stator	20
3.10	Radial duplication of Stator	21
3.11	Draw half of Armature Coil	21
3.12	Create a region of Armature Coil	22

3.13	Mirror duplication and radial duplication of armature coil	22
3.14	Draw a fraction of FE Coil	23
3.15	Create a region of FE Coil	23
3.16	Mirror duplication of FE Coil	24
3.17	Mirror duplication and radial duplication of FE Coil	24
3.18	Work Flow of experiment implementation for JMAG Designer	25
3.19	Circuit Implementation	26
3.20	Circuit Implementation for U,V and W Phase	26
3.21	The armature coil number for U phase	27
3.22	The armature coil number for V phase	27
3.23	The armature coil number for W phase	28
3.24	Direction of current for FE Coils Counter Clockwise	28
3.25	Direction of current for FE Coils	29
3.26	Design parameters of Final Improvement of 12S-10P Outer Rotor	30
3.27	Main machine dimensions of the Final Improvement design 12S-10P ORFEFSM	31
3.28	Torque versus stator radius D1 [mm]	33
3.29	Torque versus rotor pole depth , D2	33
3.30	Torque versus rotor pole width, D3	34
3.31	Torque versus FEC Slot Depth D6	34
3.32	Torque versus FEC slot width D7	35
3.33	Torque versus armature coils depth D8	35
3.34	Torque versus armature coils width D9	36
3.35	General flow of the design methodology	37
3.36	Simplified design of original 12S-10P Outer Rotor FEFSM (a) initial design (b) improvement design	38
4.1	Initial separate coil setting for armature coil test and FE Coil (12S-10P)	39
4.2	Flux linkage of coil 2, 5, 8 and 11	40

4.3	Flux linkage of coil 1, 4, 7 and 10	41
4.4	Flux linkage of coil 3, 6, 9 and 12	41
4.5	All Flux linkage of phase U, V and W	42
4.6	U Phase flux linkage at various DC FEC Current density	43
4.7	JE Flux Strengthening	43
4.8	Cogging Torque of the proposed initial ORFEFSM	44
4.9	Flux Lines of the initial design of 12S-10P from FEC , Je=10 A/mm <sup>2</sup>	45
4.10	Flux Lines of the initial design of 12S-10P from FEC , Je=20 A/mm <sup>2</sup>	46
4.11	Flux Lines of the initial design of 12S-10P from FEC , Je=30 A/mm <sup>2</sup>	46
4.12	Flux Distribution of Je=10A/mm <sup>2</sup>	47
4.13	Flux Distribution of Je=20A/mm <sup>2</sup>	48
4.14	Flux Distribution of Je=30A/mm <sup>2</sup>	48
4.15	Torque Je at various Je of the initial design Outer rotor FEFSM	49
4.16	Instantaneous torque profile at Ja = 30 Arms/mm <sup>2</sup> , Je = 30A/mm <sup>2</sup>	50
4.17	Torque and Power versus speed characteristic of the initial design FEFSM Outer Rotor	51
4.18	Instantaneous torque profile at Ja = 30 Arms/mm <sup>2</sup> , Je = 30 Arms/mm <sup>2</sup>	53
4.19	Torque versus Je at various Ja	54
4.20	Characteristics Torque versus FEC current density, Je characteristic	55
4.21	Flow of the flux	55
4.22	Ja = 30Arms/mm <sup>2</sup> , Je = 10A/mm <sup>2</sup> , T = 47.6613Nm	56
4.23	Ja = 30Arms/mm <sup>2</sup> , Je = 30A/mm <sup>2</sup> , T = 118.216N	57
4.24	Torque versus Je at maximum Ja	58
4.25	Average torque of initial and improved design ORFEFSM	58

**LIST OF SYMBOLS AND ABBREVIATIONS**

PMFSM	Permanent Magnet Flux Switching Machine
FEFSM	Field Excitation Flux Switching Machine
HEFSM	Hybrid Excitation Flux Switching Machine
<i>Nd</i>	Neodymium
<i>Dy</i>	Dysprosium
<i>Tb</i>	Terbium
CO <sub>2</sub>	Carbon dioxide
A.C	Alternate Current
D.C	Direct Current
<i>J<sub>a</sub></i>	Armature Current Density
<i>J<sub>e</sub></i>	Field Excitation Current Density
FSPM	Flux Switching Permanent Magnet
FEC	Field Excitation Coils



## CHAPTER 1

### INTRODUCTION

#### 1.1 Introduction

The flux switching motor has three distinctive features that make its operation substantially different to that of conventional two phases short pitched switched reluctance motors and other fully pitched motors. Excitation current is supplied to both the field and armature windings constantly throughout the operation of the motor for either rotor alignment position. The field winding is excited constantly with unipolar direct current that does not require switching. The switching of the current direction in the armature winding controls the orientation of the resultant stator flux and therefore to which stator poles the rotor is attracted.

Flux switching machine can be categorized into three groups that are permanent magnet (PM) FSMs , field excitation (FE) FSMs and hybrid excitation (HE) FSMs. Both PMFSM and FEFSM has only PM and field excitation coil (FEC), respectively as their main flux sources, while HEFSM combines both PM and FECs. Among these FSMs, the FEFSM offers advantages of low cost, simple construction and variable flux control capabilities suitable for various performances. [1].

The flux switching motor (FSM) is a combination of the switched reluctance motor and the inductor alternator. A flux is established in the stator of the machine by dc current flowing in the field winding (F). The orientation of the field flux is then simply switched from one set of stator poles to a quadrature set of stator poles by reversing the

polarity of the current in the armature winding. The flux switching motor is unusual in using this principle for an electric motor.

The Outer rotor type has been the topic of much interest and research. In application with high torque requirement an Outer rotor design has several advantages compared to an inner rotor one [2]. Regarding the inner rotor design, the air gap radius is limited by the space needed for the coils inside the stator and furthermore by the cooling inside the housing surrounding the laminations. The outer rotor design has the benefits that coil and cooling can be placed near the shaft, increasing the possible air gap radius [2].

## 1.2 Problem Statement

With increase in world population, demands toward vehicles for personal transportation have increased dramatically in the past decade. However, one of the serious problems associated with ever-increasing use of personal vehicles is the inevitable emissions which contribute to global warming. The conventional internal combustion engine (ICE) vehicles are the main contributors to this problem. According to the report in 2008 [3], seven per cent of global carbon dioxide (CO<sub>2</sub>) emissions in year 2000 come from vehicles. The global road transport emissions are expected to keep rising proportional with the economic growth and it is projected to double by the year 2050. Because some environmental problems, such as the greenhouse effects are directly related to vehicle emissions, government agencies and organizations have developed more stringent standards for fuel consumption and emissions.

Besides, with growing concerns over our environment, more and more automakers, governments and customers think that the electric vehicles are the future aim and personal target. While both A.C. and D.C. motors serve the same function of converting electrical energy into mechanical energy, they are powered, constructed and controlled differently [4]. The speed of a D.C. motor is controlled by varying the armature winding's current while the speed of an A.C. motor is controlled by varying the frequency, which is commonly done with an adjustable frequency drive control [5].

When using the DC motor it has many disadvantages. The overwhelming disadvantages to DC brushed machines (both series wound and other types) are the brushes themselves. Brushes ride on the commutator of the motor's armature (the part of the motor that turns) and form a rotary switch that switches high currents to various sections of the armature coils. The mechanical nature of this rotary switching of high power produces considerable electrical arcing and also mechanical wear of the carbon brushes and the copper segments of the commutator. This arcing can ignite flammable vapors if they are present around the motor. Although this condition is generally unlikely, the possibility of such ignition usually excludes brushed motors from commercially manufactured vehicles. In contrast, an AC induction motor, which has no brushes, completely eliminates this risk.

In other circumstances, an increase in annual usage of rare-earth magnet have increased the price of rare-earth metals not only Neodymium ( $N_d$ ) but also Dysprosium ( $D_y$ ) and Terbium ( $T_b$ ) which are indispensable to provide the rare-earth magnet with high coercivity as the additives. According to the report released by Mineral Resource Information Centre affiliated to Japan Oil, Gas and Metals National Corporation, a future prospect was summarized such that the production amount of  $N_{d2}F_{e14}B$  would reach at 1,500 tons only in HEV applications in 2011 and the corresponding usage of 70 tons Dysprosium would be serious problem from the viewpoints of cost, security and undersupply. Therefore, the continuous research and development of permanent magnet machines with less or no rare-earth materials would be very important.

To overcome this problem, this project is presents to design and optimization of Outer Rotor Field Excitation Flux Switching Motor for Electrical Vehicles. This research deals with design and optimization of the proposed 12S – 10P outer rotor field excitation flux switching motor for electric vehicle applications with no permanent magnet proposed.



### 1.3 Objectives

The objectives of this project is

- i) To design the Outer Rotor Field Excitation Flux Switching Motor for Electrical Vehicles application with 12S-10P
- ii) To analyse the performances of the design motor under no load, load, torque and power
- iii) To improve the initial design 12S-10P until the target performances are achieved.

### 1.4 Scopes

- i) This project is design by using JMAG Design Version 13.0 software.
- ii) The designed is target power and torque is setting respectively 10kW and 78Nm/80kg for improvement design.
- iii) The current Armature Coil Current ,  $I_a$  is set 360A, while the limit of both armature current density,  $J_a$  and FEC current density,  $J_e$  is set to 30 A/mm<sup>2</sup>

## CHAPTER 2

### LITERATUTRE REVIEW

#### 2.1 Background

The concept of flux switching permanent magnet (FSPM) has published in the 1950s. Over the last ten years, many novel and new FSMs topologies have been developed for various applications, ranging from low cost domestic appliances, automotive, wind power, aerospace, and etc [6].

#### 2.2 Classifications of Flux Switching Machine (FSM)

Generally, the FSMs can be categorized into three groups that are permanent magnet flux switching machine (PMFSM), field excitation flux switching machine (FEFSM), and hybrid excitation flux switching machine (HEFSM). Both PMFSM and FEFSM has only PM and field excitation coil (FEC), respectively as their main flux sources, while HEFSM combines both PM and FEC as their main flux sources. Fig.2.1 illustrates the general classification of FSMs

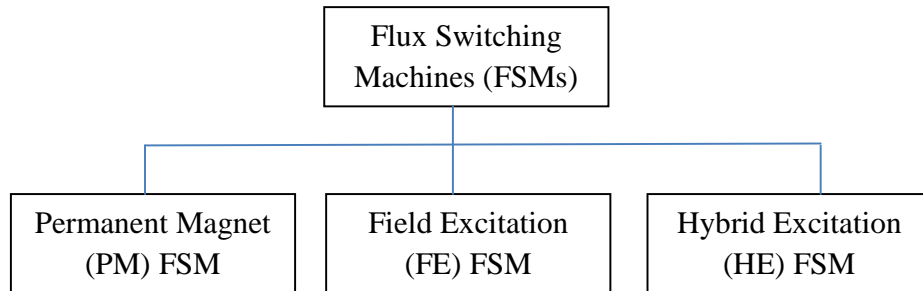

Fig. 2.1: Classification of flux switching machine (FSMs)

### 2.3 Permanent Magnet Flux Switching Machine (PMFSM)

The permanent magnet flux-switching machines (PMFSM) have a short history and have been studied for several decades. And is a relatively new category of electric machines. The basic model of PMFSM was described in [7], where Rauch and Johnson proposed a new type of motor with permanent magnets placed in the stator. Generally, such machines have a salient pole rotor and the PMs which are housed in the stator.

The PMFSM is very similar to the doubly salient permanent magnet (DSPM) machine or to the flux reversal machine (FRM) [8] [9].

However, conventional PMFSMs have a relatively poor flux weakening performance due to constant magnetic flux that required armature winding current control to operate in the flux weakening region. By applying negative d-axis current, the PM flux can be counteracted hence reducing the magnetic flux density. However, the disadvantages of increase in copper loss which significantly reduce the efficiency, and possible irreversible demagnetization of the PM are difficult to overcome. To provide further attractive characteristics, a new structure of 12S-10P PMFSM with additional field excitation coil (FEC) has been proposed [10].

The basic operation principle of the outer-rotor PMFS machine is illustrated as in Fig 2.2. The upper part is the laminated rotor similar to that of the SR machine. The lower part is the stator, where the PM and the armature winding are located. The PM is inset between two stator poles, and establishes a self-excited flux with a fixed direction within itself. In Figure 2.2 (a), the two rotor poles align with the two stator teeth which

are embraced by a concentrated winding coil. The PM flux which is linked in the coil goes out of the coil and into the rotor pole. When the rotor moves to the left, the rotor pole leaves the current stator pole and aligns with the next stator tooth which belongs to the same coil, as shown in Figure 2.2 (b). As the rotor moves, both the magnitude and polarities of the flux-linkage in the windings will vary accordingly [11].

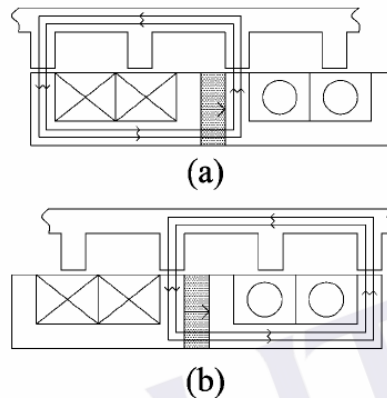

Fig. 2.2 : Operation principle at two typical rotor positions for outer rotor

The general operating principle of the PMFSM is illustrated in Fig. 2.3, where the black arrows show the flux line of PM as an example. From the figure, when the relative position of the rotor poles and a particular stator tooth are as in Fig. 2.3(a), the flux-linkage corresponds to one polarity. However, the polarity of the flux-linkage reverses as the relative position of the rotor poles and the stator tooth changes as shown in Fig. 2.3(b), i.e., the flux linkage switches polarity as the salient pole rotor rotates. In the conventional PMFSM, the stator copper area is significantly reduced since both the PMs and armature coils are housed in the stator with high PM volume employed.

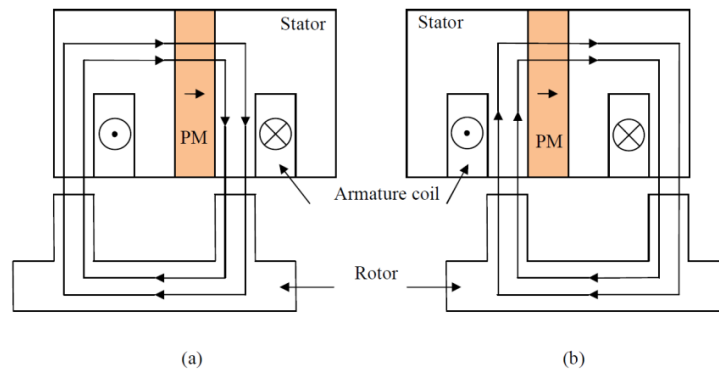

Fig. 2.3: Principle operation of PMFSM

## 2.4 Hybrid Excitation Flux Switching Machine (HEFSM)

Hybrid excitation flux switching machines (HEFSMs) are those which utilize primary excitation by PMs as well as DC FEC as a secondary source. Conventionally, PMFSMs can be operated beyond base speed in the flux weakening region by means of controlling the armature winding current. By applying negative d-axis current, the PM flux can be counteracted but with the disadvantage of increase in copper loss and thereby reducing the efficiency, reduced power capability, and also possible irreversible demagnetization of the PMs. Thus, HEFSM is an alternative option where the advantages of both PM machines and DC FEC synchronous machines are combined. As such HEFSMs have the potential to improve flux weakening performance, power and torque density, variable flux capability, and efficiency which have been researched extensively over many years [12]. However, Hybrid Excitation FSM has more complicated design compare than permanent magnet FSM and Field Excitation FSM.

The inner stator consists of the armature windings, followed by the FECs in the middle layer, while the PMs are placed in outer stator as discussed in [13] [14]. However, the machine has low torque density and long end winding for the DC FECs, which overlaps the armature windings, and increase copper loss.

The operating principle of the proposed Outer Rotor HEFSM is illustrated in Fig. 2.4. The single piece of rotor that makes the motor more robust similar to SRM is

shown in the upper part, while the stator that consists of PMs, FECs, and armature coils are located in the lower part. The PM and FEC are placed between two stator poles to generate excitation fluxes that create the term of “hybrid excitation flux”. Fig. 2.4 (a) and (b) demonstrate the flux generated by PM and FEC flow from the stator into the rotor and from the rotor into the stator, respectively, to produce a complete one flux cycle. The combined flux generated by PM and FEC established more excitation fluxes that are required to produce higher torque of the motor. When the rotor moves to the right, the rotor pole goes to the next stator tooth, hence switching the magnitude and polarities of the flux linkage. The flux does not rotate but shifts clockwise and counter clockwise in direction with each armature current reversal. According to Figs. 2.4 (c) and (d), only the PM flux flows from the stator into the rotor and from the rotor into the stator, respectively, while the FEC flux is only circulating on its particular winding slots. This condition establishes less excitation flux and generates less torque [15].

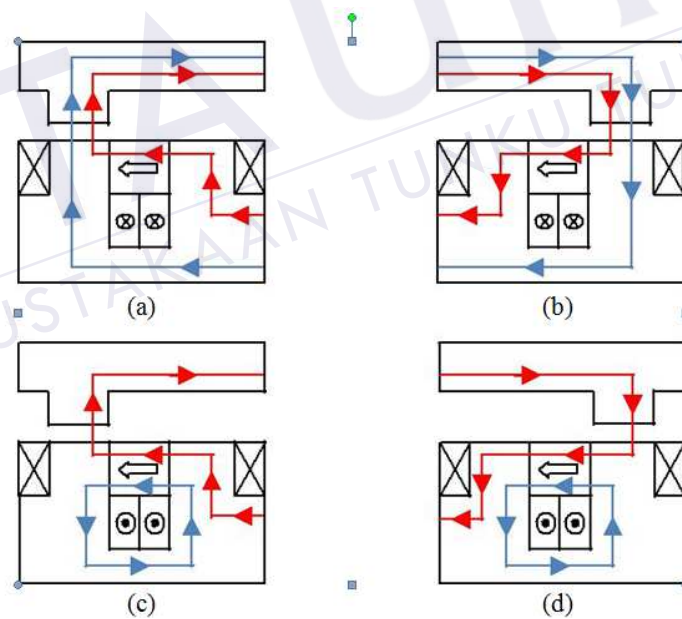

Fig. 2.4: Principle operation of ORHEFSM (a)  $\theta_e = 0^\circ$  (b)  $\theta_e = 180^\circ$  more excitation, (c)  $\theta_e = 0^\circ$  (d)  $\theta_e = 180^\circ$  less excitation

## 2.5 Field Excitation Flux Switching Machine (FEFSM)

The concept of the FEFSM involves changing the polarity of the flux linking with the armature coil windings, with respect to the rotor position. The design principle is explained in [16], and the single-phase 8S-4P FEFSM has achieved higher output power density and much higher efficiency when compared with the induction machine (IM). However, the 1-phase FEFSMs suffer with problems of low starting torque, large torque ripple, fixed rotating direction, and overlapped windings between armature coil and FEC.

To improve the performances, a 3-phase 12S-8P with segmental rotor and 24S-10P FEFSMs have been developed as shown in Figs. 2.6 and 2.7, respectively. For 12S-8P FEFSM, segmental rotor is used to provide a clear magnetic path for conveying the field flux to adjacent stator armature coil following the rotor rotation. This design gives shorter end windings than the toothed-rotor structure which is associated with overlapping coils. There are significant gains with this arrangement as it uses less conductor materials and also can improve the overall machine efficiency [17]. Furthermore, the 24S-10P FEFSM is redesigned from the 24S-10P PMFSM in which the PM is removed from the stator and half of the armature coil slots in the upper layer are placed with the FEC windings [18]. In contrast with alternate flux polarities from adjacent PM of 24S-10P PMFSM, the FEC in this machine is arranged with a sole polarity of DC current source. Since the adjacent DC FECs are isolated as shown in red circle in Fig. 2.7, the total flux generation is limited and thus reducing the performances.

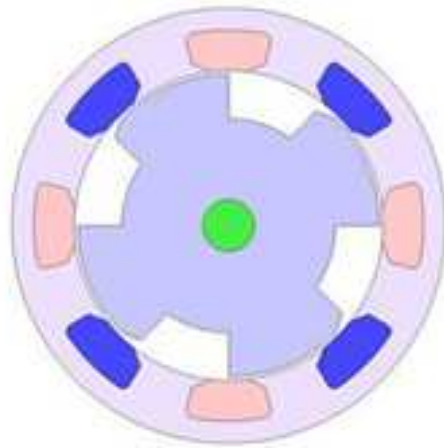

Fig. 2.5: 1-phase 8S-4P FEFSM.

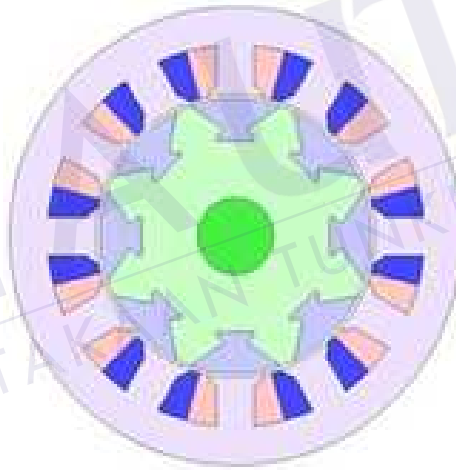

Fig. 2.6: 3-phase 12S-8P segmental rotor



## REFERENCES

- [1] S. Erwan, "Investigation on Flux Characteristics of Field Excitation Flux Switching Machine with Single FEC Polarity," *Procedia Technology* 8C, pp. 561-567, 2013.
- [2] D. Martin and W. D. Rik, "Comparison of Outer and Inner Rotor Switched Reluctance Machines," *IEEE PEDS*, 2007.
- [3] J.King, "The King Review of low carbon cars of low carbon cars-Part II: recommendations for action," March 2008. [Online]. Available: [www.hm-treasury.gov.uk/king](http://www.hm-treasury.gov.uk/king).
- [4] S. Niku, Introduction to Robotics: Analysis, Control Application 2nd Edition, 280: John Wiley & Sons, Inc, 2011.
- [5] R. S. Carrow, Electrician's technical references : Variable frequency drives, 45: Delmar Thomson Learning, 2001.
- [6] Z.Q Zhu and J.T Chen, "Advanced Flux switching Permanent Magnet Brushless Machines," *IEEE Transactions on Magnetics* , vol. 46, no. 6, June 2010.
- [7] Rauch SE and Johnson LJ, "Design principles of flux switching alternators," *AIEEE Trans*, vol. 74III, pp. 1261-1268, Jan 1955.
- [8] C. W. S. A. N. I. Boldea, "Design of a three-phase flux," *EMPS*, vol. 27, pp. 849-863, 1999.
- [9] R.P. Deodhar, S.Andersson, I.Boldea and T.J.E Miller, "The flux reversal machine : A new brushless doubly-salient permanent-magnet machine," *IEEE Trans. Ind Appl*, vol. 33, no. 4, pp. 925-934, Jul/Aug 1997.
- [10] E. Sulaiman and Takashi Kosaka, "Design Improvement and Performance Analysis of 12S-10P Permanent Magnet Flux Switching Machine with Field Excitation

Coil," *Journal of Electrical System*, pp. 425-432, 2012.

- [11] W.Fei, P.C.K Luk, J.Shen and Y.Wang, "A Novel Outer-Rotor Permanent-Magnet Flux-Switching Machine for urban electric vehicle propulsion," *IEEE International Conference on Power Electronics Systems and Applications*, pp. 1-6, May 2009.
- [12] Y.Amara, L.Vido, M.Gabsi, E.Hoang, M.Lecrivain and F.Chabot, "Hybrid Excitation Synchronous Machines: Energy Efficient Solution for Vehicle Propulsion," *IEEE Vehicle Power and Propulsion Conference*, pp. 1-6, Sept. 2006.
- [13] Y.Liao, F.Liang and T.A Lipo, "A novel permanent magnet motor with doubly salient structure," *Proc. Conf. Rec. IEEE IAS Annual Meeting*, vol. 31, no. 5, p. 308–314, October 1992.
- [14] Chau, K.T, Ming Cheng, Chan and C.C, "Nonlinear magnetic circuit analysis for a novel stator doubly fed doubly salient machine," *IEEE Trans. Magnetics*, vol. 38, no. 5, p. 2382–2384, Sep. 2002.
- [15] M.Z Ahmad, E.Sulaiman, Z.A. Haron and T.Kosaka, "Impact of rotor pole number on the characteristics of outer rotor hybrid excitation flux switching motor for In wheel Drive EV," *Procedia technology* , pp. 581-588, 2013.
- [16] B. JF, "Design of high-power density and relatively high efficiency flux-switching motor," *IEEE Trans. Energy Convers*, pp. 416-424, JUNE 2006.
- [17] M. B. A. A. Zuhu A, "A wound field three phase flux switch motor with all excitation sources on the stator," *IEEE Trans Ind. Appl*, pp. 2363 - 2371, Nov 2010.
- [18] Chen J.T, Zhu, Z.Q, Iwasaki S. and R. Deodhar, "Low Cost flux switching brushless AC machines," *Proc IEEE Vehicle Power and Propulsion Conf*, Sept 2010.
- [19] C.Pollock, H.Pollock, R. Barron, R.Sutton, J.Coles, D.Moule and A.Court, "Flux-switching motors for automotive applications," *IEEE Trans. Ind. Appl.*, pp. 1177-1184, Sep/Oct 2006.
- [20] Z. Zhu, "Switched flux permanent magnet machines: Innovation continues," *Proc Int. Conf. on Electrical Machines and Systems (ICEMS)*, pp. 1-10, 2011.