

BANDPASS FILTER DESIGN WITH SPURIOUS FREQUENCY REDUCTION
CAPABILITY

ROSNANI BINTI MUDA @ ALI

A project report submitted in partial fulfillment of the award of the Degree of Master
of Electric and Electronic Engineering

Faculty of Electrical and Electronic Engineering

Universiti Tun Hussein Onn Malaysia

JULY 2014

Specially dedicated to my beloved family,

For my friends, thank for helping and guide me for all this time.

Hope all of us will success and happy ever after.



PTTA UTHM
PERPUSTAKAAN TUNJUKU TUN AMINAH

ACKNOWLEDGEMENT

In the name of Allah S.W.T, the Most Gracious, the Ever Merciful Praise is to Allah, Lord of Universe and Peace and Prayers be upon His final Prophet and Messenger S.A.W.

Firstly, I would like to take this opportunity to thank the Almighty Allah for His mercy, His grace and kindness in my life as slave and His blessing given to me for the completion of my study in Universiti Tun Hussein Onn Malaysia.

Secondly, I would to take this opportunity to sincerely express my highest gratitude to my supervisor Dr Samsul Haimi Bin Dahlan for his guidance, idea and advice during this project.

My sincere gratitude also goes to my colleagues for their aid, ideas and advice helped me directly or indirectly.

A sincere thank to my father Haji Muda @ Ali Bin Abdullah who teach the fundamental of my life, showing me the right path and continous prayer since I was a child and also to my mother Hajjah Kuntom Binti Abdul Rahman which is the one who sincerely raised me with her caring and gentle mother's love.

Finally, I would like to thank everybody who was important to the successful realization of this thesis, as well as expressing my apology that I could not mention personally one by one.

TABLE OF CONTENTS

	TITLE	i
	DECLARATION	iii
	DEDICATION	iv
	ACKNOWLEDGEMENT	v
	CONTENTS	vi
	LIST OF TABLES	viii
	LIST OF FIGURES	ix
	LIST OF SYMBOLS AND ABBREVIATIONS	xii
	ABSTRACT	xiii
	ABSTRAK	xiv
CHAPTER 1	INTRODUCTION	1
	1.1 Introduction	1
	1.2 Problem statement	3
	1.3 Objectives	4
	1.4 Scopes	5
CHAPTER 2	THEORETICAL BACKGROUND	6
	2.1 Background	6
	2.2 Planar Bandpass Filters	8
	2.2.1 Microstrip line	8
	2.2.2 Overview of Microstrip	9
	2.2.3 Microstrip Substrates	10
	2.2.4 The advantages and disadvantages of Microstrip	10
CHAPTER 3	LITERATURE REVIEW	11
CHAPTER 4	METHODOLOGY	17
	4.1 Flowchart of Design Procedures	18
	4.2 Filter Design Method	19

4.3	The Sonnet Lite Software	21
4.3.1	Procedure of Sonnet software.	24
4.4	Fabrication Process	30
CHAPTER 5	DATA ANALYSIS AND RESULTS	36
5.1	Circuit design	36
5.1.1	Filter design specification	37
5.2	Result and analysis	39
5.2.1	Variation of coupled spacing	40
5.3	Fabrication design	41
5.3.1	Measurement Results	42
5.3.2	Comparison between the conventional and proposed	46
CHAPTER 6	CONCLUSION	49
6.1	Conclusion	49
6.2	Future Planning	50
	REFERENCES	51



LIST OF TABLES

5.1	Geometry specification	38
5.2	Dielectric layer specification	38
5.3	Analysis of the design	39
5.4	Summary of comparison between conventional parallel coupled line bandpass filter and proposed with groove.	48



PTTA UTHM
PERPUSTAKAAN TUNKU TUN AMINAH

LIST OF FIGURES

1.1	Filter types according to frequency selectivity.	2
1.2	General coupled bandpass filter	3
2.1	Response of ideal bandpass filter.	7
2.2	Filter as a two-port network with S-parameter representation	7
2.3	Microstrip Transmission Line. (a). Geometri	8
3.1	PCML structure (a) Without Groove (b). With Groove [6]	12
3.2	Geometry parameter for a optimized single groove with zeros simultaneously tuned at $\sim 2.0f_0$ [6]	12
3.3	Layout of Three Stage PCMBF with single Groove [6]	13
3.4	Parallel coupled line Filter design (a). Conventional (b). Three square grooves [7].	13
3.5	Simulated result (a). Filter centered at 2.5GHz (b). Filter centered at 10GHz [1].	14
3.6	Fabricated with groove number and S-Parameter response (a). 0, (b).2,(c).3 (d). 4, (e).7 [1]	15
4.1	The flowchart of design procedure	18
4.2	The filter design.	20
4.3	The three dimensional view of the circuit	21
4.4	Sonnet Lite Software (a). QSG menu mode. (b). Front page menu	22
4.5	Task Bar Menu for setting value of Dielectric layer	23
4.6	A Geometry Project.	23
4.7	Sonnet Project Editor	24
4.8	Specify Units Box	25
4.9	Specify Dielectric Layer	25

4.10	Specify cell and box size	26
4.11	Specify metal type	26
4.12	Add polygon	27
4.13	Angle in Polar Coordinate	27
4.14	Port located at the edge of polygon	28
4.15	Port located at the edge of polygon	29
4.16	Report of the analysis	29
4.17	Response of the conventional and proposed filter	30
4.18	Printed design on a transparent sheet	31
4.19	Laminate process.	32
4.20	UV process	32
4.21	Developer process	33
4.22	Etching process	33
4.23	Result after etching process.	34
4.24	Fabricated structure of the two- stage microstrip parallel-coupled	34
4.25	The Windfreak Synth controller.	35
4.26	The Front of Synth Network Analyser software	35
5.1	Design of PCMBF. (a) The Conventional parallel filter. (b). The proposed with Groove.	37
5.2	Simulated S_{11} and S_{21} of a two stage bandpass proposed filter.	40
5.3	The insertion loss (S_{21}) with variation of coupled-spacing.	41
5.4	Fabricated structure of the PCMBF	41
5.5	Measurement process using Network Analyser software – conventional filter.	42
5.6	Measurement process using Network Analyser software – proposed	43
5.7	Measured frequency response of the conventional and proposed	44
5.8	Measured and simulated, frequency response of the conventional	45

5.9	Measured and simulated frequency response of proposed filter	46
5.10	Simulation responses of conventional and proposed for the fabricated filters.	47



LIST OF SYMBOLS AND ABBREVIATION

PCMBPF	Parallel Coupled Microstrip Bandpass Filter
BPF	Bandpass Filter
PCML	Parallel Coupled Microstrip Line
CAD	Computer Aided Design
LAN	Local Area Network
FR4	Flame Retardant 4
W	Width
H	Height
S_{11}	Return loss
S_{21}	Insertion loss
l	Length
f_c	Center frequency
s	Gap size
d	Thickness of the substrate
ϵ_r	Dielectric constant
Z_0	Input impedance

ABSTRACT

Passband microstrip coupled line filter are widely used in daily microwave engineering practice. There are various topologies to implement microstrip bandpass filters such as end-coupled, parallel coupled, hairpin, interdigital and combine filters. This thesis discusses design, simulation, fabrication and testing using microstrip technology. The choice of a parallel coupled filter topology is discussed and an application of the grooved substrate is presented to suppress the first spurious of Parallel Coupled Microstrip Bandpass Filter (PCMBF). Band pass filters (BPF) are significant role in wireless communication systems. These filters present an undesired pass band at twice the design central frequency of the filter. The narrowband with spurious suppression is achieved by using two stage PCMBF, BPF was designed by replacing the tight couplers are arranged at the input and output of the filter whist the weak couplers at the middle section of the tight coupler with optimize groove. By using Sonnet Lite software it shown the BPF with 2.99GHz cut off frequency and bandstop of to 7GHz has been simulated and fabricated on Flame Retardant 4 (FR4) substrate by using etching process. Significant spurious suppression up to 33.23dB is measured at 5.96GHz.



ABSTRAK

Mikrostrip penapis lulus jalur digunakan secara meluas dalam kejuruteraan gelombang mikro. Terdapat pelbagai topologi untuk melaksanakan mikrostrip penapis lulus jalur seperti *end-coupler*, *parallel coupled hairpin*, *interdigital* dan *comblin*. Tesis ini membincangkan reka bentuk, simulasi, fabrikasi dan pengujian dengan menggunakan teknologi mikrostrip. Pemilihan topologi penapis selari dibincang dan penggunaan *substrate* beralur dibentangkan untuk mengurangkan *spurious* yang pertama dari *Parallel Coupled Microstrip Bandpass Filter (PCMBF)*. *Band pass filters (BPF)* berperanan penting dalam sistem komunikasi tanpa wayar. Penapis ini direka supaya melepaskan frekuensi yang tidak dikehendaki ditapis difrekuensi tengah. Pengurangan *spurious* dicapai dengan menggunakan dua peringkat *PCMBF*, *BPF* direka dengan *tight coupler* di bahagian masukan dan keluaran, manakala pada bahagian tengah, menyusun penyusunan secara *weak coupler*. Dengan menggunakan perisian Sonnet Lite dengan alur optimum menunjukkan frekuensi tengah 2.99GHz dan *bandstop* sehingga 7GHz disimulasi dan fabrikasi pada *Flame Retardant 4 (FR4) substrate* dengan menggunakan proses *etching*. Penindasan *Spurious* ketara sehingga 33.23dB diukur pada 5.96GHz.

CHAPTER 1

INTRODUCTION

1.1 Introduction

Filters are essential in the Radio Frequency (RF) front end of microwave wireless communication systems. Parallel coupled microstrip structure has been widely used as coupling components in the design of bandpass filter due to attractive features [2]. Filters are frequency selective networks designed so as to pass certain bands of frequencies and reject others. Filter are normally classified as low pass, band-pass, high-pass or band stop according to the bands it pass with low loss or in the case of the band stop filter, the band is reject. The four basic frequency responses shown in Figure.1.1, the lowpass filter, pass low frequencies from Direct Current (DC) up to the cut off frequency with no or little attenuation and attenuate high frequencies. The highpass frequencies pass above the cut off frequency and substantially reject below this frequency. The bandpass filters, pass one band frequencies and reject both higher and lower frequencies. The bandstop filters, eliminate or notch out specific frequency or band of frequencies from the frequency spectrum.

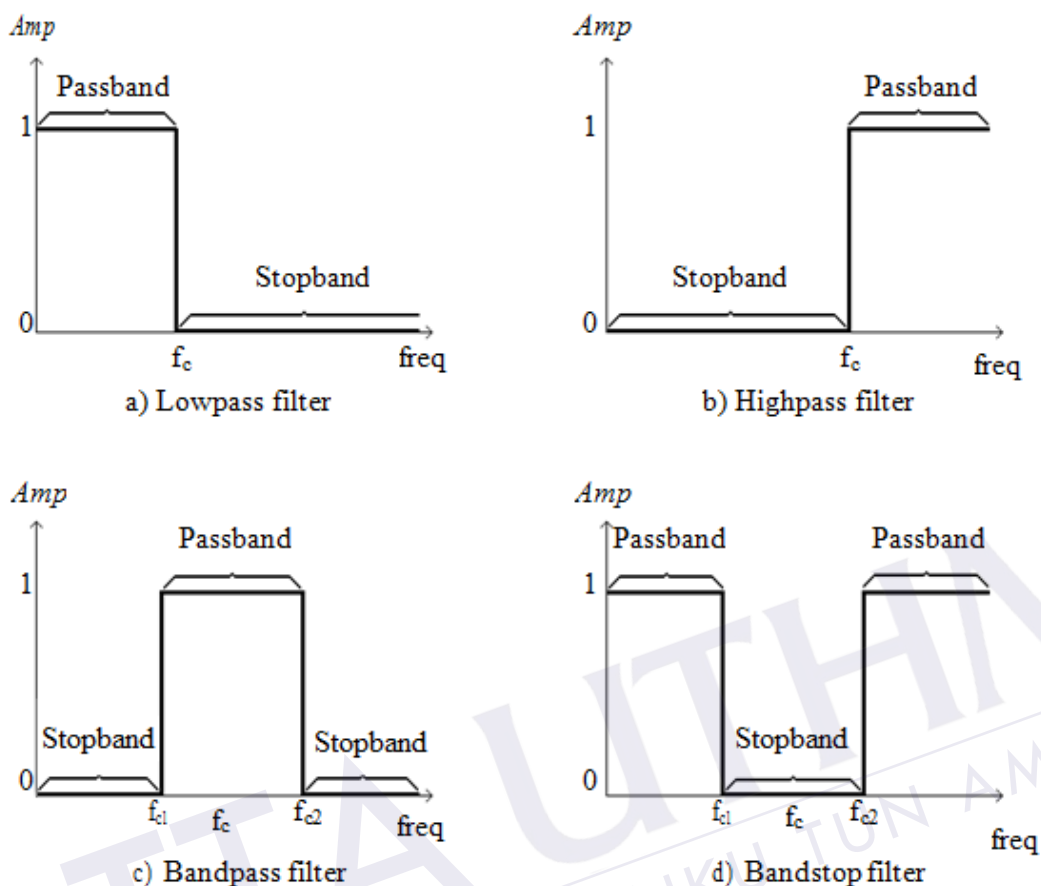

Figure 1. 1 : Filter types according to frequency selectivity.

The lowpass, bandpass and bandstop filters find important applications in signal selection in microwave systems and fabricated in microstrip. It is an important application and sometimes fabricated in microstrip in signal selection in microwave system. BPF is a passive component which is able to select signals inside a specific bandwidth at a certain center frequency and reject signals in another frequency region. Parallel-coupled microstrip bandpass filter is one of the most popular BPF and can be applied in many applications of microwave communication systems. General coupled bandpass filter is shown in Figure.1.2 illustrates a general structure of parallel coupled-line microstrip bandpass filter that uses half wavelength line resonators. This parallel arrangement gives relatively large coupling for agiven spacing between resonators, this filter structure is particularly convenient for constructing filter having wider bandwidth as compared to the other structures.

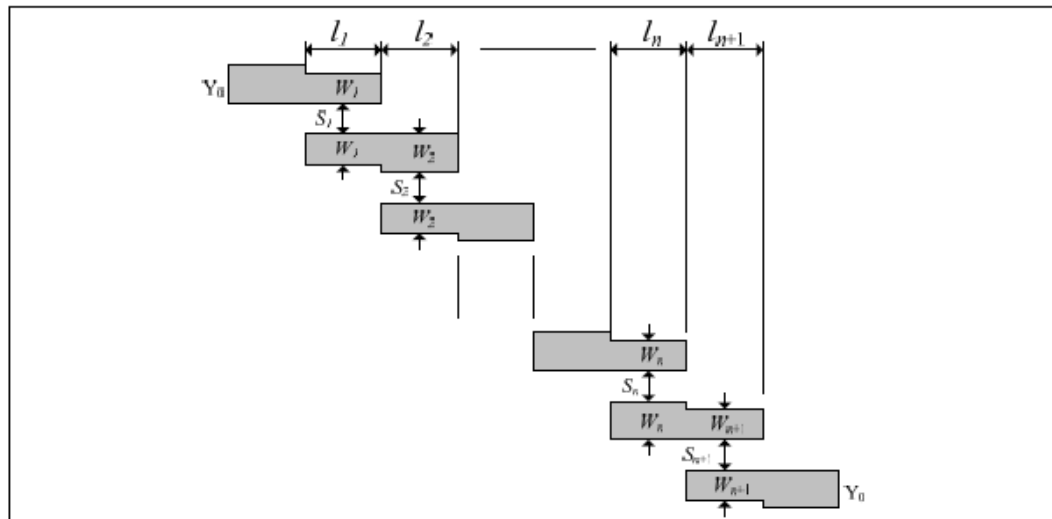

Figure 1. 2 : General structure of parallel coupled-line microstrip bandpass filter.

The filter structure is open circuited coupled microstrip lines. The components are positioned so that adjacent resonators are parallel to each other along half of their length. The resonators are coupled by means of gap capacitances between the resonator sections. The resonator lengths (l) and the coupling gaps (s) between successive resonators are important design parameters [3].

This parallel arrangement gives relatively large coupling for a given spacing between resonators and making this filter structure particularly convenient for constructing filters having a wider bandwidth as compared to other type of bandpass filter.

1.2 Problem Statement

In microwave communication systems, the bandpass filter is an essential component which is usually used in both receiver and transmitters. Thus, the quality of bandpass filter is extremely important. Parallel coupled microstrip structure has been widely used as coupling components in the design of bandpass filter due to attractive. Although microstrip parallel coupled bandpass filter with uniform coupled microstrip line sections are popular, the conventional design suffer from the spurious passband at the harmonic response at second resonance frequency.

Detection of a wanted signal may be impossible if unwanted signals and noise are not removed sufficiently by filtering. Electronic filters allow some signals to pass, but stop others. To be more precise, filters allow some signals frequencies applied at their input terminal to pass through to their output terminals with little or no reduction in signal level. The spurious passbands especially appear at twice the centre frequency ($2f_0$). This spurious response degrades the rejection properties of the system.

The presence of harmonic at second resonance frequency also worsens the performance of upper stopbands and lead degradation of the overall systems performance. These effects are mainly due to the presence of even and odd mode at the parallel-coupled elements, with difference in their velocities. The various methods that have been proposed in the literature to suppress the filter spurious passband located at twice the centre frequency ($2f_0$). A new method proposed to suppress the spurious response using a grooved substrate. The 3rd order of chebyshev response was chosen to investigate the performance of the filter, with and without periodical square grooves.

1.3 Objectives

The objectives of this project is,

- i) To designed parallel coupled bandpass filter for 2.99GHz at S- band (2GHz to 4GHz) operating frequency.
- ii) To analyse the performance of the designed filter in terms of frequency response, reduce at the first spurious passband.
- iii) To compare between simulation result and measurement result by referring at frequency response.

1.4 Scopes

- i) Design and analyse the results by using Sonnet Lite software, an analyse response referring in term of S-parameter insertion loss (S_{21}) and return loss (S_{11}).
- ii) Analyse the result by comparing simulation and measurement for conventional and proposed filter design. The filter characteristic according a shape of groove with specified dimension will be proposed.
- iii) The microstrip filter on the FR4 board was fabricate by using etching technique, to operate at S-band frequency (2GHz- 4GHz) useful in full-duplex local area network (LAN) communication.



CHAPTER 2

THEORETICAL BACKGROUND

2.1 Background

Parallel Coupled Microstrip Bandpass Filters (PCMBF) is widely employed in many microwave systems. Designs of PCMBF used the Parallel Coupled Microstrip Line (PCML) structure as the main coupling component [2]. The required design parameters of bandpass filter can be easily derived for Butterworth, Chebyshev or other prototype in many literatures [4]. A microstrip filter is a two port network used to control the frequency response at a certain point in a microwave system by providing transmission at frequencies within the passband of the filter and attenuation in the stopband of the filter [5]. Filters are frequency selective networks designed so as to pass certain bands of frequencies and reject others. Filter are normally classified as low-pass, band-pass, high-pass or band stop according to the bands it pass with low loss or in the case of the band stop filter, the band it reject. Low-pass, band-pass and band stop filters find important applications in signal selection in microwave systems. An example of response of ideal bandpass filter is shown in Figure. 2.1.

Today, most microwave filter design is done with sophisticated computer-aided design (CAD) packages based on the insertion loss method [2]. CAD packages are now available which enable direct determination of input impedance (Z_o) and other data for given substrate of width (w), height (h), thickness (t), dielectric constant (ϵ_r) and frequency input.

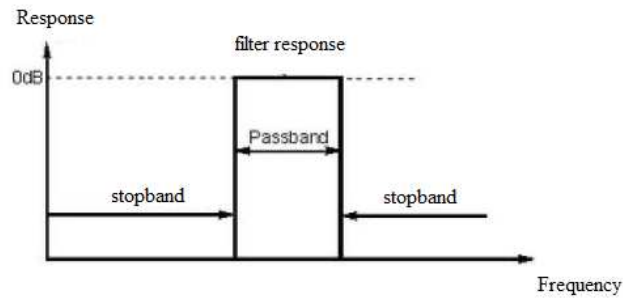

Figure 2. 1: Response of ideal bandpass filter.

Most RF/microwave filter and filter components can be represented with a two port network as shown in Figure. 2.2, where V_1 , V_2 and I_1 , I_2 are voltage and current variables at ports 1 and 2. The terminal impedances, Z_{01} and Z_{02} and E_s is the source.

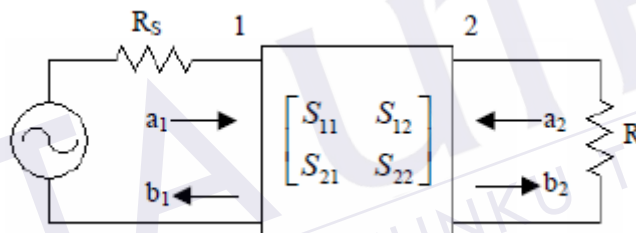

Figure 2. 2 : Filter as a two-port network with S-parameter representation.

The scattering or S parameters of a two port network are defined as;

$$\begin{aligned} S_{11} &= \frac{b_1}{a_1} |_{a_2=0} & S_{12} &= \frac{b_1}{a_2} |_{a_1=0} \\ S_{21} &= \frac{b_2}{a_1} |_{a_2=0} & S_{22} &= \frac{b_2}{a_2} |_{a_1=0} \end{aligned} \quad (2.1)$$

Where $a_n=0$ no reflection from terminal impedance at port n , be written as:

$$\begin{bmatrix} b_1 \\ b_2 \end{bmatrix} = \begin{bmatrix} S_{11} & S_{12} \\ S_{21} & S_{22} \end{bmatrix} \begin{bmatrix} a_1 \\ a_2 \end{bmatrix} \quad (2.2)$$

The parameters S_{11} and S_{22} are reflection coefficients and S_{12} and S_{21} the transmission coefficients. The parameter directly measurable at microwave frequencies and an amplitudes are given in decibels (dB), are defined as ;

$$20 \log |S_{mn}| \text{ dB} \quad m, n = 1, 2 \quad (2.3)$$

2.2 Planar Bandpass Filters

Bandpass filter is one of the most important filter in the communications systems, it can be classified by bandwidth to narrowband, wideband and ultra-wideband filter. The main challenging for designers is to design a bandpass filter with compact size, low lossless and wide stopband.

2.2.1 Microstrip line

Many electromagnetic circuits are implemented with the form of transmission line structures based on planar printed circuit boards (PCBs), which are composed of a dielectric material layer and ground/signal metal planes. One of the most widely used transmission lines for high frequency circuits in microstrip line. The microstrip are used for circuit components such as filters, coupler, resonator, antenna and so on. In comparison with the coaxial line, the microstrip line allows for greater flexibility and compactness of design [6]. A microstrip line consists of a dielectric substrate covered by metal layers on both sides, one for signal line and other one for the ground plane. The geometry of a microstrip line is shown in Figure. 2.2.

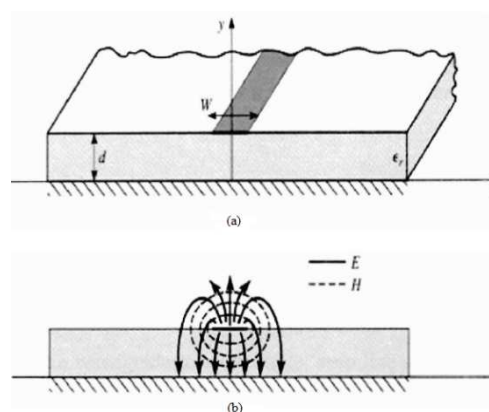

Figure 2. 3 : Microstrip Transmission Line. (a). Geometri
(b). Electric and Magnetic Field Lines

Which,

W = is the width of printed thin conductor

d = is the thickness of the substrate

ϵ_r = is the dielectric of the substrate

The top conductor strip, the dielectric substrate and conductor ground plate form a microwave transmission line. The combine structure acts as a guide to the transmission of electromagnetic waves. Although it's open structure has some limitations it is an especially suitable medium for the connection of microwave integrated circuit devices. It is ideal for applications where low volume and weight are important and lends itself to methods of high volume and low cost production.

Microstrip is used over the frequency range from below 1GHz to 40GHz. Below 1GHz circuit dimensions become excessively large, above 40GHz circuit dimensions are very small and circuit lossless become high.

2.2.2 Overview of Microstrip

The microstrip structure does not have dielectric above the strip (as in stripline). So, microstrip has some usually most of the field lines in the dielectric region, concentrated between the strip conductor and the ground plane. Some of the function in the air region above substrate and the microstrip line cannot support a pure TEM wave. In most practical application, the electric substrate is electrically very thin ($d \ll \lambda$). The field are quasi TEM (the fields essentially same as those of the static case). Microstrip is by far the most popular microwave transmission line, especially for microwave integrated circuits and MMICs (Monolithic microwave Integrated circuits). The major advantage of microstrip over stripline is that all active components can be mounted on the top of the board. The disadvantages are that when high isolation is required such as in a filter or switch, some external shielding may have to be considered. Given the chance, microstrip circuits can be radiates, causing unintended circuit response. A minor issue with microstrip is that it

is dispersive meaning that signals of different frequencies travel at slightly difference speeds [5].

2.2.3 Microstrip Substrates

The characteristic of some substrate materials are ideally a substrate should have very low-loss and constant dielectric properties over the range of frequencies for which it is used, excellent temperature and dimensional stability. It should be chemically resistant, be easy to machine and provide a good thermal expansion to the strip conductor material.

2.2.4 The advantages and disadvantages of Microstrip

The microstrip has their own advantages compare to other microwave transmission like waveguide, coaxial cable, strip line and etc.

The advantage of microstrip :

- a) To make easier fabrication of complex circuit.
- b) Smaller size and light.
- c) Has a good reliability
- d) Has a wide bandwidth
- e) Good reproducibility

The disadvantages of microstrip :

- a) Using the microstrip lines will be given high attenuation.
- b) Using the microstrip will generate the low power.

CHAPTER 3

LITERATURE REVIEW

Coupled microstrip lines have been widely in design of bandpass filters in many microwave systems. Various methods have been reported the article “Spurious Response Suppression in Microstrip Parallel Coupled Bandpass Filter by Grooved Substrates” (Mahdi Moradian and Majid Tayarani, 2008) [6]. The articles present an application of the grooved substrate to suppress response of microstrip parallel coupled line filter. The proposed method, the grooves are cut along the outer edge of each coupled line of the conventional filter and the other to equalize the modal phase velocities. It is shown that the grooves equalize the even and odd mode phase velocities in microstrip coupled line and suppress the spurious response. The simulation result shows that the selected groove shapes also have a effect on the designed filter performance.

The article “Harmonic Suppressed Single Groove PCML Bandpass Filter”, (Jayaseelan Marimuthu and Mazlina Esa, 2009) [7]. The article present the design of single groove parallel-coupled microstrip bandpass filter with improved passband and filter harmonic suppression. The undesired filter harmonic spurious response is suppressed through transmission zero frequency realignment method. The suppression of harmonic response carried out by transmission zero realignment method using a simple modification a single groove at the center PCML structure. A single groove is introduced at the center of PCML structure to control the transmission zero which depends on even and odd mode parameter. Figure. 3.1 shows the layout of a PCML structure of width (w), gap size (s) and length (l), with and without groove. H and W are the height and width of the single groove. For a given bandwidth, operating frequency and passband response, the w , s and l of each

structure are calculated by using even mode impedance Z_{oe} , and electrical length θ_e , odd mode impedance Z_{oo} , and electrical length θ_o . The geometric parameters of a single groove in PCML wg for simultaneously tuning zeros at $\sim 2.0 f_0$ harmonic suppression for various PCML structures. The results of optimized single groove dimensions for various PCML structures with $w = 1.0$ mm and $s = 0.2$ mm, 0.4 mm, 0.6 mm, 0.8 mm and 1.0 mm are given in Figure.3.2. When s increased, respective harmonic suppression groove of larger size is required. The odd mode propagation with increasing s , the coupling between the two strips decreases and the wave travels faster. The groove width increased to compensate or slow down its phase velocity.

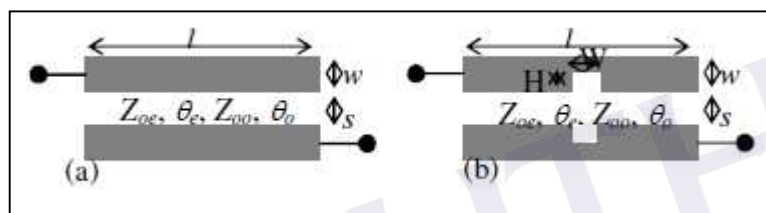

Figure.3. 1: PCML structure (a) Without Groove (b). With Groove [7]

Three-stage PCMBF designed with various combination of single-stage with optimized groove for harmonic suppression at different operating bandwidths.

Figure.3.3 shows a three-stage PCMBF with optimized groove.

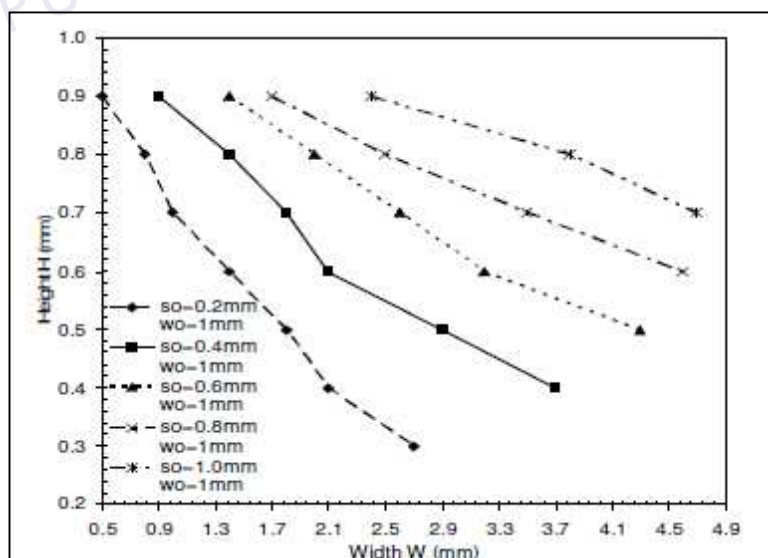

Figure.3. 2 : Geometry parameter for a optimized single groove with zeros simultaneously tuned at $\sim 2.0f_0$ [7]

REFERENCES

- [1] Jae W.Lee, Myung S.Song Bong S.Kim, *An Implementation of harmonic Suppression Microstrip Filters with Periodic Grooves*, vol. 14, no. 9, pp. 413-415, September 2004.
- [2] David M.Pozar, *Microwave Engineering 3rd Edition*. New York: Wiley, 2005.
- [3] Annapurna Das Sisir K Das, *Microwave Engineering*. New Delhi: Tata McGraw-Hill, 2000.
- [4] Jorge Hernandez, Miguel Bacaicoa, David Benito, Maria J.Garde, Mario Sorolla, Marco Guglielmi Miguel A.G.Laso, "New Microstrip "Wiggly-Line" Filters With Spurious Passband Suppression ," *IEEE Transactions On Microwave Theory and Technique*, vol. 49, no. 9, pp. 1593-1597, SEPTEMBER 2001.
- [5] David M.Pozar, *Microwave Engineering*, 3rd ed. New York: Wiley, 2005.
- [6] Matthew N.O.Sadiku, *Element of Electromagnetics*, 3rd ed. New York: Oxford , 2001.
- [7] Mahdi Moradian and Majid Tayarani, "Spurious Response Suppression in Microstrip Parallel Coupled Bandpass Filters by Grooved Substrates," *IEEE Transactions on Microwave Theory and Techniques*, vol. 56, no. 7, pp. 1707-1713, July 2008.
- [8] Mazlina Esa Jayaseelan Marimuthu, *Harmonic Suppressed Single Groove PCML Bandpass Filter*, 29 September - 1 October 2009.
- [9] Chi-Yang and Tatsuo Itoh, "A Modified Parallel Coupled Filter Structure That Improve The Upper Stopband Rejection and Response Symmetry ," *IEEE Trans. On Microwave Theory and Techniques* , vol. 39, no. 2, pp. 31-314, Feb 1991.
- [10] B.Ester and K.A.Merze, "Parallel Coupled Line Filter for Inverted Microstrip and Suspended Ss," *11th Eur.Microwave Conf. Dig*, pp. 164-176, 1981.
- [11] Wei-Hsiu Hsu, Wei-Ting Huang Jen-Tsai Kuo, *Parallel Coupled Microstrip Filters with Suppression of Harmonic Response*, vol. 12, no. 10, pp. 283-285, October 2002.
- [12] Sonnet 14.53 Lite Plus User Guide, Sonnet Software Inc.USA.
- [13] http://www.windfreaktech.com/doc/synthnv/wfapp1_1.pdf.

[14] <http://www.windfreaktech.com/rf-signal-generator-and-power-detector.html>.

[15] Steven W. Smith, *Digital Signal Processing*, Second Edition ed. San Diego, California: California Technical Publishing, 1999.



PT TA UTHM
PERPUSTAKAAN TUNKU TUN AMINAH