

DESIGN IMPROVEMENT OF OUTER-ROTOR HYBRID EXCITATION FLUX
SWITCHING MOTOR FOR IN-WHEEL DRIVE ELECTRIC VEHICLE

WAN NORHASHIMAH BINTI WAN HUSIN

A project report submitted in partial
fulfillment of the requirement for the award of the
Degree of Master of Electrical Engineering

Faculty of Electrical and Electronics Engineering
Universiti Tun Hussein Onn Malaysia

JULY 2014

Special dedication to my beloved family,

Mohd Hashimi bin Abas (Husband),

Salhah Tamedon binti Ahmad and Wan Husin bin Wan Ali (Parents),

Mah binti Abdullah and Abas bin L. Awang (Parents-in-law),

All Family Members



ACKNOWLEDGEMENT

I would like to express my sincere gratitude and appreciation towards my project supervisor, Dr. Erwan bin Sulaiman for his supervision and guidance. Without his valuable advice, ideas support and encouragement throughout this project, I'm definitely not being able to complete this project.

A special thanks to my beloved husband and family, for their love, support, encouragement, inspiration and honest sacrifice for me to settle this project. To appreciate their immense contribution, this thesis is lovingly dedicated to them.

Last but not least, I also would like to extend my gratitude to my fellow friends, colleagues and others who have provided assistance at various occasions. Their views and tips are useful indeed. Without all these people helps, support and advices, this project might not be successfully carried out. Thanks you once again.



PTIA UTM
PERPUSTAKAAN TINGKAT UTM AMINAH

ABSTRACT

Due to in-wheel motors definite benefits of great controllability for each self-reliant wheel as well as the convenience of more space of cabin due to conventional mechanical transmission and differential gears are removed, more study and research of in-wheel motors used in pure electric vehicles (EVs) propulsion systems have attracted and involved great attention lately. Furthermore, more series batteries can be mounted to gain the distance of driving. The main necessities are to have high torque density and efficiency, since the motors are installed directly to the wheel. Because of high torque possibility is required; a design of outer-rotor hybrid excitation flux switching motor for in-wheel drive electric vehicle is suggested in this project. The suggested motor consists of twelve (12) slots of stator poles, and ten (10) rotor poles. All these active parts are placed on the stator. Secondly, it has a steady rotor assembly which only contains a single piece of rotor and has a wide range flux control abilities. Under some design restrictions and specifications for the target electric vehicle drive applications, the performance of the suggested machine on the initial design and improved design are analyzed based on 2-D finite element analysis (FEA). The performance of the improved design motor shows that the maximum torque achieved is 241.7921 Nm which is 72.61 % of the target performance, whereas the maximum power has achieved 143.47 kW which is greater than the target value. Therefore, by extra design optimization it is estimated that the motor will successfully reach the target performance.

ABSTRAK

Oleh kerana motor dipasang terus ke roda, pastinya kebolehkawalan bagi setiap roda adalah yang terbaik serta mempunyai ruang kabin lebih luas disebabkan sistem enjin dan gear mekanikal yang biasa ditanggalkan, maka lebih banyak kajian dan penyelidikan berkenaan pemasangan motor terus ke roda yang digunakan bagi kereta elektrik mendapat perhatian ramai pengkaji. Tambahan pula, bateri siri boleh dipasang bagi menambah jarak pemanduan. Keperluan utama adalah untuk mendapatkan ketumpatan daya kilas dan kecekapan yang tinggi apabila motor dipasang terus ke roda. Oleh kerana daya kilas yang tinggi diperlukan, rekabentuk *outer-rotor hybrid excitation flux switching motor* adalah dicadangkan dalam projek ini. Cadangan motor terdiri dari 12 slot kutub pemegun dan 10 kutub pemutar. Bahagian aktif seperti magnet, anker berlilit dan gegelung pengujaan berada di pemegun. Sebagai tambahan, ia mempunyai satu binaan pemutar yang stabil di mana mempunyai pelbagai kebolehan kawalan fluks. Di bawah beberapa sekatan dan spesifikasi reka bentuk bagi sasaran aplikasi kereta elektrik, prestasi motor yang dicadangkan bagi rekaan awal dan rekaan penambahbaikan dianalisa berdasarkan kepada *2-D finite element analysis (FEA)*. Prestasi bagi rekabentuk penambahbaikan menunjukkan bahawa daya kilas mencapai nilai maksimum pada 241.7921 Nm di mana ianya adalah 72.61 % bagi prestasi sasaran. Manakala kuasa maksimum yang berjaya dicapai adalah 143.47 kW di mana nilai tersebut adalah melebihi dari nilai sasaran. Oleh itu, dengan mengoptimumkan reka bentuk dianggarkan motor akan berjaya mencapai prestasi sasaran yang dikehendaki.

CONTENTS

	TITLE	i
	DECLARATION	ii
	DEDICATION	iii
	ACKNOWLEDGEMENT	iv
	ABSTRACT	v
	CONTENTS	vii
	LIST OF TABLES	x
	LIST OF FIGURES	xi
	LIST OF SYMBOLS AND ABBREVIATIONS	xiii
CHAPTER 1	INTRODUCTION	1
	1.1 Project Overview	1
	1.2 Problem Statement	2
	1.3 Objectives of Project	4
	1.4 Scope of Project	4
CHAPTER 2	LITERATURE REVIEW	6
	2.1 Introduction to Electric Motor	6
	2.2 Review on Electric Vehicle (EV)	7
	2.3 Review on Electric Motor used in Electric Vehicle (EV)	8
	2.4 Reviews on Flux Switching Motors (FSMs)	9
	2.4.1 Permanent Magnet Flux Switching Machine (PMFSM)	10
	2.4.2 Field Excitation Flux Switching Synchronous Machine (FEFSM)	11

2.4.3	Hybrid Excitation Flux Switching Motor (HEFSM)	13
2.4.4	Principle Operation of ORHEFSM	14
2.5	Relationship between Torque, Speed and Power	16
2.6	The Electric Motor Design Software	18
CHAPTER 3	METHODOLOGY	20
3.1	JMAG-Designer	20
3.2	Project Implementation in Geometry Editor	21
3.2.1	Rotor	22
3.2.2	Stator	23
3.2.3	Permanent Magnet (PM)	24
3.2.4	Field Excitation Coil (FEC)	25
3.2.5	Armature Coil (AC)	25
3.3	Project Implementation in JMAG-Designer	26
3.3.1	Material Setting	26
3.3.2	Conditions Setting	27
3.3.3	Circuit Setting	28
3.3.4	Mesh	29
3.3.5	Magnetic Study and Properties Setting	30
3.3.6	Simulation and Results Observation	31
3.4	The Design of 12Slots – 10Poles ORHEFSM	32
3.5	The Improved Design of 12Slots – 10Poles ORHEFSM	34
CHAPTER 4	RESULT AND ANALYSIS	36
4.1	Introduction	36
4.2	Open Circuit Analysis	38
4.2.1	Armature Coil Arrangement Test	38
4.2.2	Zero Rotor Position Analysis	41
4.2.3	Flux Strengthening	42
4.2.4	Flux Lines and Flux Distributions	43
4.3	Load Analysis	45

4.3.1	Torque versus J_a at various J_e	45
4.3.2	Torque versus Speed	47
4.4	Motor Weight Calculation	48
4.5	Conclusion	48
CHAPTER 5	CONCLUSION AND RECOMMENDATION	49
5.1	Introduction	49
5.2	Conclusion	49
5.3	Recommendation	50
	REFERENCES	51



LIST OF TABLES

1.1	ORHEFSM design restrictions and specification for electric vehicle	5
2.1	Advantages and disadvantages of FSM	10
3.1	Description of icon used in Geometry Editor	22
3.2	Materials setting	27
3.3	Parameters of 12Slots - 10Poles ORHEFSM	33
3.4	The parameters of improved design	35
4.1	The differences of parameters between initial design and improved design for the proposed ORHEFSM	37
4.2	Motor weight	48



LIST OF FIGURES

1.1	Single motor drive for EV drivetrain system configuration	3
1.2	In-wheel motor drive for EV drivetrain configuration	3
2.1	Classification of electric motor	6
2.2	US light vehicle sales and fleet composition under baseline scenario	8
2.3	Principle operation of PMFSM	11
2.4	Principle operation of FEFSM (a) $\theta_e = 0^\circ$ and (b) $\theta_e = 180^\circ$ flux moves from stator to rotor (c) $\theta_e = 0^\circ$ and (d) $\theta_e = 180^\circ$ flux moves from rotor to stator	12
2.5	The operating principle of the proposed HEFSM (a) $\theta_e=0^\circ$ - more excitation (b) $\theta_e=180^\circ$ - more excitation (c) $\theta_e=0^\circ$ - less excitation (d) $\theta_e=180^\circ$ - less excitation	14
2.6	Principle operation of ORHEFSM (a) $\theta_e = 0^\circ$ (b) $\theta_e = 180^\circ$ more excitation, (c) $\theta_e = 0^\circ$ (b) $\theta_e = 180^\circ$ less excitation	16
2.7	Performance Characteristics of Electric Motor	17
3.1	Work flow of project implementation	21
3.2	Toolbar icons	22
3.3	Radial duplication of rotor	23
3.4	Radial duplication of stator	24
3.5	PM filled in the stator	24
3.6	FEC parts design	25

3.7	Complete design of 12S-10P ORHEFSM	26
3.8	Step to material setting	27
3.9	Conditions setting	28
3.10	Circuit implementation (a) Armature coil circuit (b) FEC circuit (c) UVW circuit	29
3.11	Mesh generated in ORHEFSM (a) Mesh properties (b) Mesh view	30
3.12	Setting in study magnetic (a) Step control (b) Conversion	31
3.13	Steps involved in simulate and results observation (a) Run active case (b) Show data value	32
3.14	The design structure of ORHEFSM	32
3.15	Design parameters defined as $D_1 - D_{10}$	33
3.16	The improved design structure	35
4.1	Improved design structure of 12slot-10pole ORHEFSM	37
4.2	Armature coil setting for coil test analysis	40
4.3	Initial three phase flux linkage	40
4.4	Improved three phase flux linkage	41
4.5	Zero rotor position for initial 12Slot – 10Pole ORHEFSM	42
4.6	Zero rotor position for improved 12Slot – 10Pole ORHEFSM	42
4.7	The ORHEFSM flux strengthening graph for both designs	43
4.8	Flux lines	44
4.9	Flux distributions	44
4.10	Torque versus J_a at various J_e of initial design	45
4.11	Torque versus J_a at various J_e of improved design	46
4.12	Torque versus J_a at maximum J_a	46
4.13	Torque versus speed of initial design	47
4.14	Torque versus speed of improved design	47

LIST OF SYMBOLS AND ABBREVIATIONS

A	-	Ampere
AC	-	Alternating current
DC	-	Direct current
f	-	Frequency
f_e	-	The electrical frequency
f_m	-	The mechanical frequency
J_a	-	Maximum current density in armature coil
J_e	-	Maximum current density in FEC
k	-	Integer
kg	-	Kilogram
kW	-	Kilo Watt
mm	-	Milimeter
Nm	-	Newton meter
N_r	-	The number of rotor poles
N_s	-	The number of stator slot
q	-	Number of phase
rms	-	Root mean square
rpm	-	Revolutions per minute
r/min	-	Revolutions per minute
s	-	Second
T	-	Torque
V	-	Voltage
Wb	-	Weber
θ	-	Angle
o	-	Degree

Φ - Flux
% - Percent



CHAPTER 1

INTRODUCTION

1.1 Project Overview

Demands toward vehicles for personal transportation have increased with world population increasing. According to Kavan Mukhtyar, the Asia-Pacific partner and head of Automotive and Transportation Practice, the average global population use private transport was 53 percent [1]. The sheer number of vehicles on the road contributes to global warming. These vehicles emit carbon dioxide which pollutes the atmosphere [2]. It is rather well-known that a new scientific finding that, counter to what most of us believe, driving a car causes more global warming pollution than flying the same distance in a plane [3]. The conventional internal combustion engine (ICE) vehicles are the main contributors to this problem. This scenario occurs in many countries are no exception to Malaysia. One of the solutions to the fuel consumption like petrol used to propel the car would now focus on electrical technology. Because of environmental problems likes the greenhouse effects are directly related to vehicles emissions, electric vehicles have involved increasing interest from vehicle manufactures, governments and consumers. The battery-powered electric vehicles (BEVs) seem like the best solution to deal with energy and environmental problem since they zero oil consumption and zero emissions [4]. The Malaysia Government through The Ministry of Energy, Green Technology and Water has also looked towards the support of electric vehicles (EV) and energy efficient vehicles (EEV) in the country offers the potential for Malaysia to reduce need on fossil fuels. Therefore, to make possible the use of EV in the country, the Government has finished the EV Infrastructure Roadmap, and the next phase is the

ongoing fleet test programmed for electric vehicles in Putrajaya and Cyberjaya. The implementation of this fleet test will be the benchmark in developing a strategic plan and framework as well as the identification of entities that will benefit the electric vehicle industry in areas of services and new business opportunities [5]. Meanwhile, Mukhtyar said, a research shows that 50 percent of transport consumer in Kuala Lumpur would rather switch to fuel-efficient vehicles leading to an increase in eco-friendly vehicles in Malaysia. On 2013, hybrid car sales are projected to grow by 4.2 percent to 16,000 units refer to the tax exemption and the launch of new models [1]. Electric car giving many benefits to people so electric car was the best solution. Imagine a car without gasoline, we do not need to go to the gas station to get petrol anymore but only enough to charge in front of the house or parking of vehicles is provided. Presently, research and development have focused on developing the electric vehicle. So, the necessary conditions of basic characteristics of an electric motor for electric vehicle drive system are: (1) high power and torque density; (2) wide speed range and constant power; (3) high starting torque for hill climbing ability and high power in speed cruising; (4) high efficiency over wide speed and torque ranges; (5) high reliability and robustness appropriate to environment; (6) Intermittent overload ability and acceptable cost; (7) Low acoustic noise and low torque ripple; (8) good voltage regulation over wide speed [6].

1.2 Problem Statement

Nowadays the EV is become more popular. The common system configuration applied in EV drivetrain is single motor drive which has centralized motor drive with reduction gears and a differential axle as illustrated in Figure 1.1. The centralized drive appears to be popular partly due to its similarity with existing ICE based system. However this system has some shortcomings due to conventional mechanical transmission and differential gear. The solution of in-wheel motor drive applied as illustrated in Figure 1.2 has great controllability for each independent wheel as well as the availability of more cabin space due to taking away of conventional mechanical transmission and differential gears. In addition, more series batteries can be located to

increase the driving distance and long-lasting even though everyday use. Due to the removal of mechanical transmission, differential gears and drive belts, the in-wheel direct drivetrain provides fast torque response, higher efficiency, weight decrease and increased vehicle space. At the same time, the cost to develop can reduce and the car is able to be more compact.

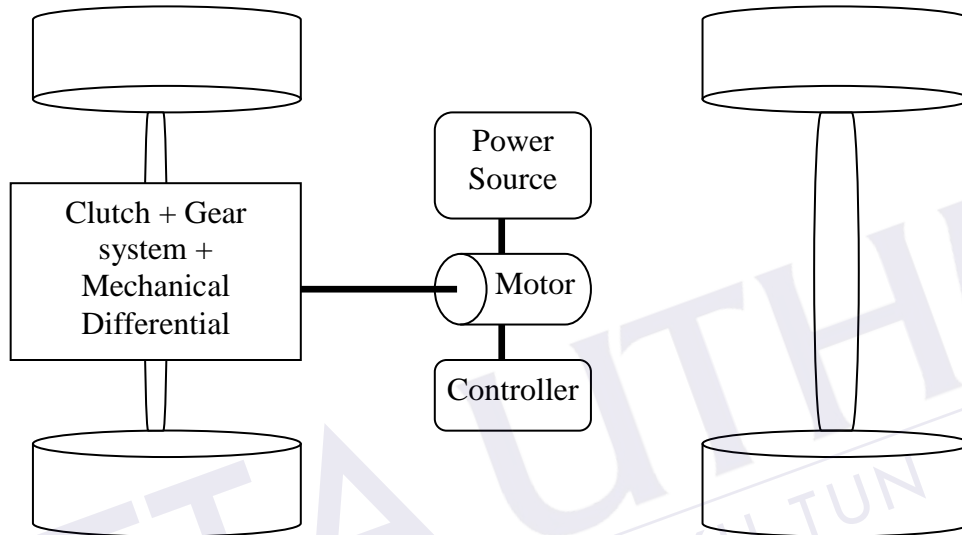

Figure 1.1: Single motor drive for EV drivetrain system configuration

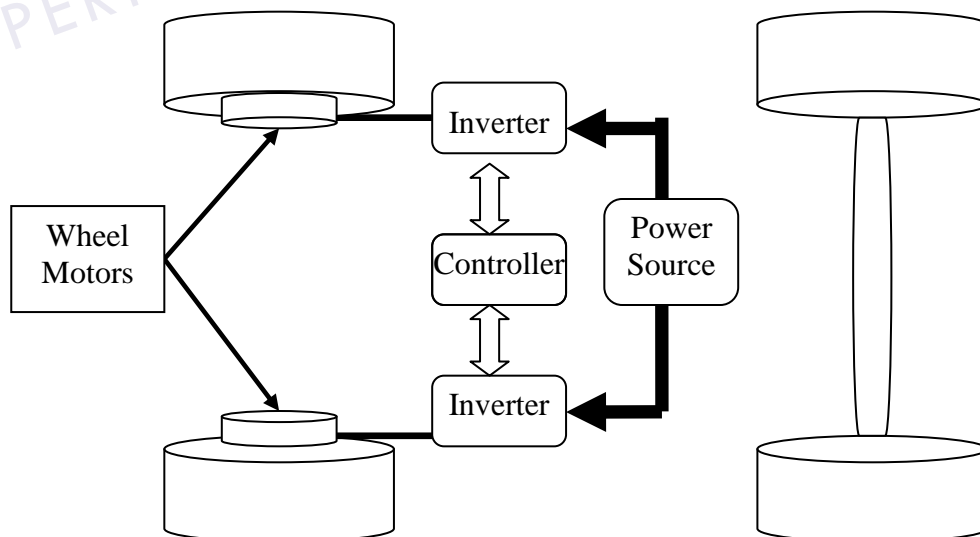

Figure 1.2: In-wheel motor drive for EV drivetrain configuration

1.3 Objectives of Project

The objectives of this project are:

- i. To design an Outer-Rotor Hybrid Excitation Flux Switching Motor for In-Wheel Drive Electric Vehicles (ORHEFSM).
- ii. To analyse the performances of the design under similar motor restrictions and specifications installed in existing electric vehicle.
- iii. To improve the torque and power performances of the design.

1.4 Scope of Project

The scope of project has been determined in order to achieve the objectives of this project. The proposed motor consists of 12 slots of stator poles and 10 rotor poles. The development of the project design is using JMAG-Designer 12.1.02 and the implementation of the simulation and analyzed based on 2-D finite element analysis (FEA). The design restrictions and specifications for the proposed motor ORHEFSM are similar with interior permanent magnet synchronous motor (IPMSM) employed in LEXUS RX400h and list in Table 1.1.

The target maximum torque and power are set to be more than 333 Nm and 123 kW. The target weight of the proposed motor is set to be at least similar as inner rotor HEFSM which is 35 kg. Therefore, the proposed motor is expected to achieve the maximum power and torque density of 9.5 Nm/kg and 3.5 kW/kg, respectively. The corresponding electrical restrictions to the inverter such as maximum DC bus voltage and maximum inverter current are set to 650 V and 360 A_{rms}. While, the maximum current density in armature coil and field excitation field is set to 30 A/mm² [7].

Table 1.1: ORHEFSM design restrictions and specification for electric vehicle

Descriptions	Inner rotor HEFSM	Outer-rotor HEFSM
Max DC-bus voltage inverter (V)	650	650
Max. Inverter current (A_{rms})	360	360
Max. Current density in armature coil, J_a (A_{rms}/mm^2)	30	30
Max. Current density in FEC, J_e (A/mm^2)	30	30
Motor radius (mm)	132	132
Motor stack length (mm)	70	70
Shaft/Inner motor radius (mm)	30	30
Air gap length (mm)	0.8	0.8
PM weight (kg)	1.1	1.1
Maximum torque (Nm)	333	>333
Maximum power (kW)	123	>123



CHAPTER 2

LITERATURE REVIEW

2.1 Introduction to Electric Motor

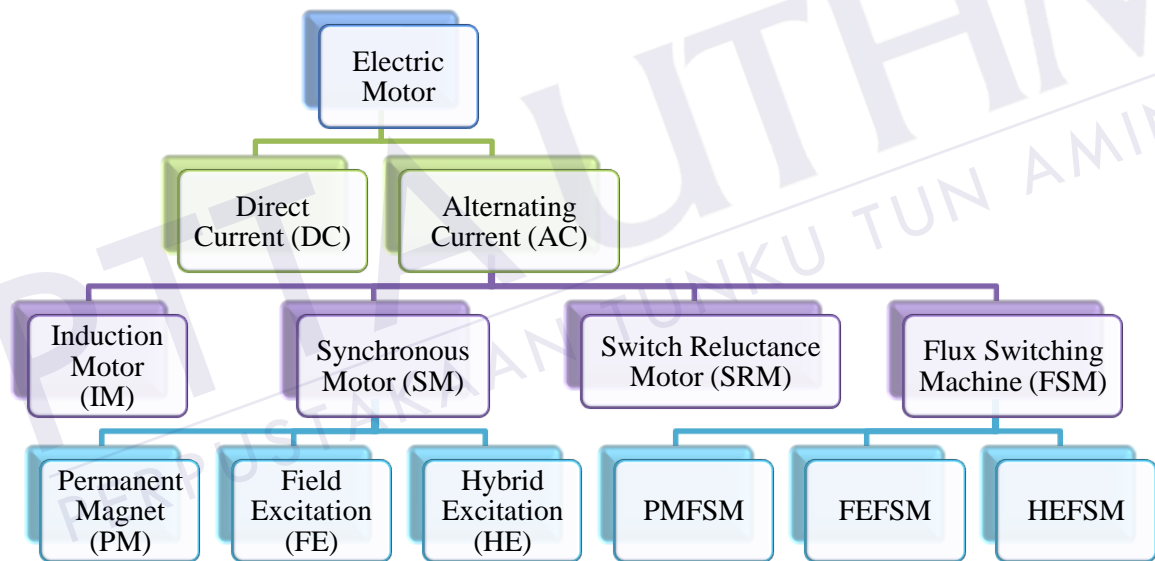

Figure 2 1: Classification of electric motor

The electrical motor is a device that has brought about one of the biggest advancements in the fields of engineering and technology ever since the invention of electricity. An electric motor is an electro-mechanical device that converts electrical energy to mechanical energy. There are different types of motor have been developed for different specific purposes. The types of electric motor can be classified as shown in Figure 2.1 above. Basically, electric motor divided into two groups which are direct

current and alternating current. Have four types in alternating current motor group whereas induction motor (IM), synchronous motor (SM), switch reluctance motor (SRM) and flux switching machine. Synchronous motor divided into three types, there are permanent magnet, field excitation and hybrid excitation. Furthermore, flux switching machine also divided into three as same as in synchronous motor.

All of these motors work in more or less same principle. An electromagnet is the basis of an electric motor. An electric motor is all about magnets and magnetism. Electric motor generally working depends upon the interaction between an electric motor's magnetic field and electric current to generate force within the motor.

2.2 Review on Electric Vehicle (EV)

All-electric vehicles (EVs) depend on electricity only. They are run by an electric motor (or motors) powered by rechargeable battery packs. EVs have several advantages compared to vehicles with internal combustion engines (ICEs). It is well known that electric vehicles have the qualities of energy-saving, non-emission and low noise pollution, and called as "green car". A green car produces less harmful effects to the environment than comparable conventional internal combustion engine vehicles running on gasoline.

From a study of the Centre for Entrepreneurship and Technology at University of California, Berkeley, electric cars could comprise 64-86% of US light vehicle sales by 2030 [8]. The study in Figure 2.2 shows rapid acceptance for electric vehicles with switchable batteries, calculates how the electrification of the United State (U. S.) transportation system will cut America's necessity on foreign oil, increase employment, and reduce the environmental effect of transportation emissions by conventional car. From this study, the electric vehicle and the development of high performance electric motor is a force to be reckoned with.

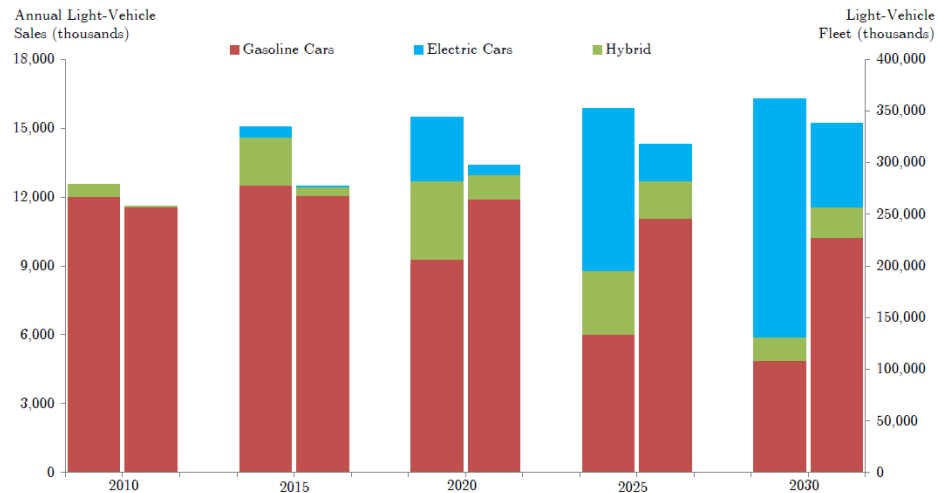

Figure 2.2: US Light Vehicle Sales and Fleet Composition under Baseline Scenario

2.3 Review on Electric Motor used in Electric Vehicle (EV)

An electric vehicle (EV) uses one or more electric motors for propulsion. Electric motors give electric cars instant torque, creating strong and smooth acceleration using electrical energy stored in batteries or another energy storage device. The electric motor is the heart of electric vehicle which offer the driving part that moves electric vehicle in many situation.

The electric motor comes in different shapes, driving methods, types and function. Nevertheless, the necessary conditions of basic characteristics of an electric motor for electric vehicle drive system need to studies as mentioned in past literature, are summarized as follows:-

- i. high power and torque density
- ii. wide speed range and constant power
- iii. high starting torque for hill climbing ability and high power in speed cruising
- iv. high efficiency over wide speed and torque ranges
- v. high reliability and robustness appropriate to environment
- vi. intermittent overload ability and acceptable cost
- vii. low acoustic noise and low torque ripple
- viii. good voltage regulation over wide speed [6].

Many types of electric motor already used in study of research and developments. Like permanent magnet synchronous machines (PMSMs) with an outer-rotor have been used as in-wheel direct drive motors for EVs, due to their high torque density, superb efficiency and overload capability [9]. But, in extreme driving conditions there probably will be risks of demagnetization and mechanical harm of the rotor's magnet. Alternatively, the switched reluctance motor (SRM) has the simplest and strong rotor structure with no magnets, which makes it mainly tough against mechanical and thermal effects. SRMs also have huge torque ripples and its make them incompatible for direct drive. Lately, study and development on permanent magnet flux switching machine (PMFSM) has turn into more interesting suitable to a number of excellent characteristics of physical compactness, steady rotor construction, greater torque, power density and great efficiency. So, the PMFSM inherits preferred advantages of both of the PMSM and SRM [10-13]. Then, the outer-rotor structure is more proper for direct drive use, the PMFSM with outer-rotor has been designed only for light EV use [14-15]. It provides basically sinusoidal back-electromotive force (emf) with high torque at low speed. But, constant PM flux of PMFSM makes it hard to control since it requires field weakening flux at high speed conditions. Moreover, with quick increase in the price of rare-earth PM on the stator, it will affect the cost of the motor. While, outer-rotor hybrid excitation flux switching machine (ORHEFSM) with less rare-earth magnet and field excitation coil on the stator is simple structure of motor and can give more higher in torque and power density [16].

2.4 Reviews on Flux Switching Motors (FSMs)

In the mid of 1950s the initial idea of flux switching motor (FSM) was founded and published. Many novel and new FSM topologies have been developed over the last decade or so for various applications, ranging from low cost domestic purposes, automotive, wind power, aerospace, and others. The term of flux switching is introduced due to changing of the polarity of the flux linkage by following the motion of salient pole rotor.

In general, the FSMs can be classified into three groups that are permanent magnet flux switching machine (PMFSM), field excitation flux switching machine (FEFSM), and hybrid excitation flux switching machine (HEFSM) as shown in Figure 2.1. PMFSM has only PM, while FEFSM has field excitation coil (FEC) as their main flux sources. Whereas HEFSM combines both PM and FEC as their main flux sources [17-18]. Moreover, the FEC can be used to control the generated flux with variable capabilities. The advantages and disadvantages of FSM must be considered are listed in Table 2.1 [19].

Table 2.1: Advantages and disadvantages of FSM

Advantages	Disadvantages
<ul style="list-style-type: none"> i. Simple and robust rotor structure suitable for high speed applications ii. Easy to manage magnet temperature rise as all active parts are located in the stator iii. Flux focusing / low cost ferrite magnets can also be used iv. Sinusoidal back-emf waveform which is suitable for brushless AC operation 	<ul style="list-style-type: none"> i. Reduced copper slot area in stator ii. Low over-load capability due to heavy saturation iii. Complicated stator iv. Flux leakage outside stator v. High magnet volume for PMFSM

2.4.1 Permanent Magnet Flux Switching Machine (PMFSM)

Permanent magnet flux switching machine have been studied for several decades. Generally, such machines have a salient pole rotor and the Permanent magnet which is located in the stator. The salient pole rotor is like to SRMs, which is more robust and suitable for high speed applications. The difference is only in the number of rotor poles and stator teeth are two. Difference with conventional IPMSM, the slot area is reduced when the magnets are moved from the rotor to the stator. To dissipate the heat from the

stator it is become easier and the temperature rise in the magnet can be controlled by proper cooling system.

The general operating principle of the PMFSM is shown in Figure 2.3. The black arrows show the flux line of PM as an example. When the relative position of the rotor poles and a particular stator tooth are as in Figure 2.3 (a), the flux-linkage corresponds to one polarity. But, the polarity of the flux-linkage reverses as the relative position of the rotor poles and the stator tooth changes as shown in Figure 2.3 (b), the flux linkage switches polarity as the salient pole rotor rotates.

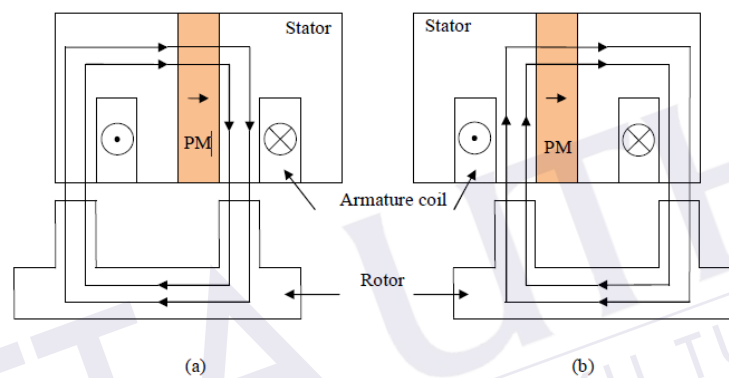

Figure 2.3: Principle operation of PMFSM

2.4.2 Field Excitation Flux Switching Synchronous Machine (FEFSM)

FEFSM is a form of salient-rotor reluctance machine with a novel topology, combining the principles of the inductor generator and the SRMs [20-21]. The concept of the FEFSM involves changing the polarity of the flux linking with the armature winding, with respect to the rotor position. The viability of this design was demonstrated in applications requiring high power densities and a good level of durability [22]. The single-phase FEFSM is very simple motor to manufacture, coupled with a power electronic controller and it has the potential to be extremely low cost in high volume applications. Moreover, it inherently offers longer life and very flexible and precise control of torque, speed, and position at no additional cost by being an electronically commutated brushless motor,

REFERENCES

- [1] Bernama, "41 peratus responden di KL anggap kesesakan lalu lintas kekecewaan nombor satu: Online Berita Harian," 8 January 2014. [Online]. Available: <http://www.bharian.com.my>. [Accessed 12 July 2014].
- [2] The Malaysian Times, "Global warming, a warning to all: The Malaysian Times," 30 July 2012. [Online]. Available: <http://www.themalaysiantimes.com.my/>. [Accessed December 2013].
- [3] Z. Shahan, "Cars Cause Global Warming More than Planes, Study Finds: Clean Technica," 9 August 2010. [Online]. Available: <http://cleantechnica.com>. [Accessed December 2013].
- [4] International Energy Agency Implementing Agreement on Hybrid and Electric Vehicles, "Outlook for hybrid and electric vehicles: IA-HEV Outlook," 2008. [Online]. Available: <http://www.ieahev.org>. [Accessed December 2013].
- [5] Kettha, "Speech by YB Dato' Sri Peter Chin Fah Kui Minister of Energy, Green Technology and Water, Malaysia at The 4th International Conference on Energy and Environment 2013 (ICEE 2013): Kettha," 22 March 2013. [Online]. Available: <http://www3.kettha.gov.my>. [Accessed December 2013].
- [6] W.Xu, J. Zhu, S. W. Y. Guo, Y. Wang and Z. Shi, "Survey on electrical machines in electrical vehicles," in *International Conference on Applied Superconductivity and Electromagnetic Devices*, Chengdu, 2009.
- [7] M. Ahmad, E. Sulaiman, Z. Haron and T. Kosaka, "Design improvement of a new outer-rotor hybrid excitation flux switching motor for in-wheel drive EV," in *Power Engineering and Optimization Conference (PEOCO), 2013 IEEE 7th International*, Langkawi, 2013.
- [8] T. A. Becker and I. Sidhu, "Electric Vehicles in the United States A New Model with Forecast to 2030," University of California, Berkeley, 2009.
- [9] W. Fei, P. Luk and K. Jinupun, "A new axial flux permanent magnet Segmented-

- Armature-Torus machine for in-wheel direct drive applications," in Power Electronics Specialists Conference, 2008. PESC 2008. IEEE, Rhodes, 2008.
- [10] S. Rauch and L. Johnson, "Design Principles of Flux-Switch Alternators," in *Power Apparatus and Systems, Part III. Transactions of the American Institute of Electrical Engineers*, Santa Barbara, 1955.
- [11] Y. Chen, S. Chen, Z. Zhu, D. Howe and Y. Ye, "Starting torque of single phase flux switching permanent magnet motors," in *Magnetics, IEEE Transactions on* (Volume:42 , Issue: 10), Sheffield , 2006.
- [12] E. Hoang, M. Lecrivain and M. Gabsi, "A New Structure of a Switching Flux Synchronous Polyphased Machine," in *European Conference on Power Electronics and Applications*, Sheffield, 2007.
- [13] Y. Amara, E. Hoang, M. Gabsi and M. Lecrivain, "Design and comparison of different flux-switching synchronous machines for an aircraft oil breather application," r, no. 15, pp. 497-511,2005.," in *Euro. Trans Electr. Powe*, France, 2005.
- [14] W. Fei, P. Chi, K. Luk and J. S. Y. Wang, "A Novel Outer-Rotor Permanent-Magnet Flux-Switching Machine for Urban Electric Vehicle Propulsion," in *3rd International Conference on Power Electronics Systems and Applications (PESA)*, pp. 1–6, 2009.
- [15] W. Fei, P. Chi, K. Luk, S. Member, J. X. Shen, Y. Wang, and M. Jin, "A Novel Permanent-Magnet Flux Switching Machine With an Outer-Rotor Configuration for In-Wheel Light Traction Applications," *IEEE Transactions on Industry Applications*, vol. 48, no. 5, pp. 1496–1506, 2012
- [16] M.Z. Ahmad, E. Sulaiman, Z.A. Haron, and T. Kosaka, "Preliminary Studies on a New Outer-Rotor Permanent Magnet Flux Switching Machine with Hybrid Excitation Flux for Direct Drive EV Applications", *IEEE Int. Power and Energy Conference (PECON2012)*, pp. 928-933, Dec 2012.
- [17] Sulaiman E, Kosaka T, Matsui N. High Power Density Design of 6slot-8pole Hybrid Excitation Flux Switching Machine for Hybrid Electric Vehicles, *IEEE Trans. On magn.*, Oct. 2011, vol. 47, no. 10 p. 4453-4456
- [18] Sulaiman E, Kosaka T, Matsui N. Design Optimization and Performance of a Novel 6-slot 5-pole PMFSM with hybrid Excitation for Hybrid Electric Vehicle,

- IEEJ Trans. Ind. Appl., 2012, vol. 132, no. 2, sec. D, p.211-218
- [19] Sulaiman E. (2012). *Design Studies on Less Rare-Earth and High Power Density Flux Switching Motors with Hybrid Excitation/ Wound Field Excitation for HEV Drives*. Nagoya Institute of Technology, Japan: Ph.D. Thesis.
- [20] Walker JH. The theory of the inductor alternator, J. IEE, June 1942, vol.89, no.9, pp.227–241.
- [21] Miller TJE. *Switched Reluctance Machines and Their Control*, Hillsboro, OH: Magna Physics, 1993.
- [22] Pollock, C., Pollock, H. and Brackley, M. 2003. Electronically controlled flux switching motors: A comparison with an induction motor driving an axial fan, Proc. Conf. Rec. IEEE IAS Annual Meeting : 2465–2470
- [23] Y. Amara, L. Vido, M. Gabsi, E. Hoang, M. Lecrivain, and F. Chabot: “Hybrid Excitation Synchronous Machines: Energy Efficient Solution for Vehicle Propulsion”, IEEE Vehicle Power and Propulsion Conference, VPPC 06, pp.1-6, Sept. 2006
- [24] C. Zhao, and Y. Yan: “A review of development of hybrid excitation synchronous machine”, Proc. of the IEEE International Symposium on Industrial Electronics, 2005, Vol.2, pp.857-862, June 2005
- [25] R. L. Owen, Z.Q. Zhu, and G.W. Jewell: “Hybrid excited flux-switching permanent magnet machines”, Proc. 13th European Conf. on Power Electronics and Applications, EPE 2009, Barcelona, Spain, pp.1-10, 2009
- [26] Ehsani, Mehrdad. (2005). *Modern electric, hybrid electric, and fuel cell vehicles*. CRC.
- [27] Xue, X. D., Cheng, K. W. E., & Cheung, N. C. (2008). *Selection of electric motor drives for electric vehicles*.
- [28] Overview of electric motor design softwares [Online] Available at: <https://www.emotor.com/blog/post/overview-electric-motor-design-softwares/> (Accessed on Jan 2014).