

**SMART TORQUE CONTROL FOR OVERLOADED MOTOR USING
ARTIFICIAL INTELLIGENCE APPROACH**

HAZIZUL BIN MOHAMED

A project report submitted in partial
Fulfillment of the requirement for the award of the
Degree of Master of Electrical Engineering



PTTA UTHM
PERPUSTAKAAN TUNKU TUN AMINAH

Faculty of Electrical and Electronic Engineering
Universiti Tun Hussein Onn Malaysia

JANUARY, 2013

ABSTRACT

This project report presents a methodology for implementation of a rule-based fuzzy logic controller applied to an induction motor torque control. The designed Fuzzy Logic Controller's performance is weighed against with that of a PI controller. The pros of the Fuzzy Logic Controllers (FLCs) over the conventional controllers are they are economically advantageous to develop, a wider range of operating conditions can be covered using FLCs, and they are easier to adapt in terms of natural language. Another advantage is that, an initial approximate set of fuzzy rules can be impulsively refined by a self-organizing fuzzy controller. For torque control of the induction motor, a reference torque has been used and the control architecture includes some rules. These rules portray a nonchalant relationship between two inputs and an output, all of which are nothing but normalized voltages. These are the input torque error denoted by Error (e), the input derivative of torque error denoted by Change of error (Δe), and the output frequency denoted by Change of Control (ω_{sl}). The errors are evaluated according to the rules in accordance to the defined member functions. The member functions and the rules have been defined using the FIS editor given in MATLAB. Based on the rules the surface view of the control has been recorded. The system has been simulated in MATLAB/SIMULINK® and the results have been attached. The results obtained by using a conventional PI controller and the designed Fuzzy Logic Controller has been studied and compared.



ABSTRAK

Laporan projek ini membentangkan kaedah bagi pelaksanaan pengawal logic *fuzzy* berasaskan peraturan yang digunakan untuk kawalan daya kilas motor peraruh. Prestasi pengawal logic *fuzzy* yang direka ini dibandingkan dengan dengan prestasi pengawal kamiran (*propotional intergral, PI*). Kebaikan Pengawal Logik Fuzi (FLCs) ke atas pengawal konvensional ialah mempunyai kelebihan daripada ekonomi untuk pembangunan sistem, julat yang luas dalam pengoperasian dan mereka lebih mudah untuk menyesuaikan diri dalam segi bahasa tabii. Satu lagi kelebihan ialah, satu set penghampiran awal untuk peraturan logic *fuzzy* boleh didorong oleh pengawal fuzzy kawalan diri. Untuk kawalan daya kilas motor peraruh, daya kilas rujukan telah digunakan dan seni bina kawalan mengandungi beberapa peraturan. Peraturan-peraturan ini menggambarkan hubungan sambil lewa antara dua masukan dan keluaran, di mana kesemuanya adalah tidak mempunyai apa-apa kecuali voltan ternormal. Peraturan-peraturan tersebut ialah kesilapan masukan daya kilas yang ditandakan oleh Ralat (e), terbitan kesilapan masukan daya kilas yang ditandakan oleh Perubahan kesilapan (Δe), dan frekuensi keluaran yang ditandakan oleh Perubahan Kawalan (ω_{sl}). Kesilapan-kesilapan dinilai merujuk kepada peraturan-peraturan yang selaras dengan fungsi-fungsi ahli-ahli set yang telah ditakrifkan. Fungsi-fungsi ahli dan peraturan telah ditakrifkan menggunakan editor FIS yang diberikan dalam MATLAB. Asas kepada peraturan pandangan permukaan kawalan telah direkodkan. Sistem ini telah disimulasi dengan menggunakan perisian MATLAB / SIMULINK dan keputusan yang telah diperolehi dilampirkan. Keputusan yang diperolehi dengan menggunakan satu pengawal PI konvensional dan Pengawal Logik *fuzzy* yang direka telah dikaji dan dibandingkan.



CONTENTS

TITLE	i
DECLARATION	ii
DEDICATION	iii
ACKNOWLEDGEMENT	iv
ABSTRACT	v
CONTENTS	vii
LIST OF TABLES	x
LIST OF FIGURES	xi
LIST OF SYMBOLS AND ABBREVIATIONS	xii
CHAPTER 1: INTRODUCTION	1
1.1 Project Background	1
1.2 Problem Statement	2
1.3 Project Objective	2
1.4 Scope of the Project	2
1.5 Layout of Thesis	3
CHAPTER 2 : LITERATURE REVIEW	4
2.1 Induction Motor	4



2.2	Overloaded Motor	6
2.3	Motor Torque	7
2.4	Artificial Intelligence	9
2.5	Fuzzy Logic Controller	10
2.6	Fuzzy Logic as an Evolutionary Computational Tool	11
2.7	Classical Set and Fuzzy Set: A Comparison	11
2.8	Fuzzy Sets with a Continuous Universe	12
2.9	Fuzzy Set-Theoretic Operations	13
2.10	Formulating Membership Functions	16
2.11	Summary	17

CHAPTER 3 : METHODOLOGY **19**

3.1	Project Methodology	19
3.2	Literature reviews on previous works in torque control method	19
3.3	Fuzzy Logic Control	21
3.4	Design fuzzy logic controller method and its algorithm	22
3.5	Develop a smart torque control for overloaded motor using artificial intelligence.	24

CHAPTER 4 : FUZZY LOGIC CONTROLLER DESIGN **26**

4.1	Direct Torque Controller (DTC)	26
4.2	Fuzzy Logic Controller Design	29
4.3	Membership Function Design	29
4.4	Rule Base Design for the Output (ω_{fl})	31
4.5	Design of the Fuzzy Logic Controller using MATLAB	32
4.6	Summary	39



CHAPTER 5 : MATLAB SIMULATION	40
5.1 Direct Torque Control (DTC) Controller	40
5.2 Simulation Results	43
5.3 Comparison between FLC and PI Controller Results	52
5.4 Summary	61
CHAPTER 6 : CONCLUSION AND RECOMMENDATIONS	
6.1 Conclusion	62
6.2 Recommendations For Future Work	63
REFERENCES	56



PTTA UTHM
PERPUSTAKAAN TUNKU TUN AMINAH

LIST OF TABLES

4.1	Fuzzy sets and the respective membership functions for torque error (e)	29
4.2	Fuzzy sets and the respective membership functions for Change in Error (Δe)	30
4.3	Fuzzy sets and the respective membership functions for Change of Control (ω_{it}).	31
4.4	Fuzzy Rule Table for Output (ω_{it})	31



PTTA UTHM
PERPUSTAKAAN TUNKU TUN AMINAH

LIST OF FIGURES

2.1	Induction motor.	5
2.2	Types of ac induction motor rotors	5
2.3	Torque of three-phase motor	8
2.4	Torque of single-phase motor as the rotor accelerates from zero to full speed.	8
2.5	Basic fuzzy logic control block diagram	10
2.6	Example of Classical Set and Fuzzy set	11
2.7	Membership Function on a Continuous Universe	12
2.8	The concept of containment or subset	14
2.9	Operations on Fuzzy sets	15
2.10	Types of membership functions	16
2.11	Examples of four classes of parameterized MFs	17
3.1	Field oriented control scheme for motor drives	20
3.2	Basic direct torque control scheme for motor drives	21
3.3	Basic fuzzy logic control scheme for motor drives	22
3.4	Fuzzy controller block diagram	23
3.5	Fuzzy logic based control system	23
3.6	Project flow chart.	25
4.1	Space vector diagram of DTC	27
4.2	Conventional direct torque control diagram	28
4.3	Diagram of DTC with fuzzy logic controller	28
4.4	FIS editor window in MATLAB	35
4.5	FIS editor : fuzzy-control window in MATLAB	36

4.6	Membership function for the input Error (e)	37
4.7	Membership function for the input Change in Error (Δe)	37
4.8	Membership function for the output Change of control (ω_{Sl})	38
4.9	Three dimensional plot of the control surface	38
4.10	Rule viewer with inputs $e = 0$ and $\Delta e = 0$	39
5.1	Block diagram for DTC controller	40
5.2	Block diagram of direct torque control of induction motor using fuzzy logic controller	42
5.3	Output waveform for stator current	43
5.4	Output waveform for rotor speed	44
5.5	Output waveform for electromagnetic torque	45
5.6	Output waveform for stator current	46
5.7	Output waveform for rotor speed	47
5.8	Output waveform for electromagnetic torque	48
5.9	Stator current waveform DTC using FLC versus DTC using PI for 100 V supply for rotor speed	50
5.10	Rotor speed waveform DTC using FLC versus DTC using PI for 100 V supply	52
5.11	Electromagnetic torque waveform DTC using FLC versus DTC using PI for 100 V supply	54
5.12	Stator current waveform DTC using FLC versus DTC using PI for 1000 V supply	56
5.13	Rotor speed waveform DTC using FLC versus DTC using PI for 1000 V supply	58
5.13	Electromagnetic torque waveform DTC using FLC versus DTC using PI for 1000 V supply	60



PTTA UTHM
PERPUSTAKAAN TUNJUKKAN AMINAH

LIST OF SYMBOLS AND ABBREVIATIONS

e.m.f	-	Electromotive force
PI	-	Proportional integral
AI	-	Artificial intelligence
DSP	-	Digital signal processing
e	-	Error
Δe	-	Change of error
ω_{cl}	-	Change of control
λ_s	-	Stator flux
λ_r	-	Rotor flux
$\delta\lambda$	-	Torque angle
$\Delta\lambda_s$	-	Stator flux increment
P	-	Poles
T_e	-	Torque



PERPUSTAKAAN TUNKU TUN AMINAH

CHAPTER 1

INTRODUCTION

1.1 Project Background

An electric motor is a device for converting electrical power into mechanical power [1]. An electric motor will try to deliver the required power even at the risk of self-destruction. In the use of onsite, motors for various reasons, often lead the overload failure occurred. Motor overload will lead to the motor overheated, cause the motor burning, and cause significant damage to the national economy. Therefore, to prevent this happening, a smart control method is needed to overcome the motor overload problem. One of the affected parameter in case of overload problem is the motor torque. Torque is one of the important parameters in a motor. The torque is proportional to the speed.

Through this project, an artificial intelligence method will be used to control the motor torque when the motor is overloaded. Artificial intelligence that will be used are based on fuzzy logic method. Fuzzy logic is a technique to embody human-like thinking into a control system. Fuzzy logic showed very useful to solved non-linear control problems. It's also allows a simpler and more robust control solution whose performance can only be matched by a classical controller with adaptive characteristics. The advantages provided by a fuzzy logic controller is it operates in a knowledge –based way and its knowledge relies on a set of linguistic such as if-then rules like a human logic.

1.2 Problem Statements

Machines are easily damage without implementation of control methodology in it system. Frequently, the desired performance characteristics of control systems are specified in terms of the transient response. The transient response of a practical control system usually exhibits damped oscillation before reaching steady state. One of the causes that can damage the motor is overload. This overload problem will affect the transient response of torque and the motor speed. Therefore, the motor performance will be affected. To solve this problem, a method of an artificial intelligence will be designed to control the motor torque when the motor is in overload conditions.

1.3 Project Objectives

The objectives of this project are as follows:

- i. To develop a smart controller to control the torque of an overloaded motor by using fuzzy logic approach.
- ii. To implement and simulate the controller using MATLAB/Simulink.
- iii. To analyse the performance of the controller.

1.4 Project Scopes

This project is to design a smart controller that can be used to control the torque of an overloaded motor. It also will examine the performance of a motor with implementation of control methodology. Thus, the focuses of this project are as stated below:

- i. The use of an artificial intelligence method as a smart controller.
- ii. Implementing and perform simulation of the proposed smart controller by using MATLAB/Simulink.
- iii. Compare the performance of propose smart controller with others controller.

1.5 Layout of Thesis

This documentation deals with the proposed idea of a fuzzy controller for a torque control of an induction motor. This report is divided into eight chapters. Chapter 1 is an introduction and gives an overview of the project and speaks about the scope and the main objective.

Chapter 2 discusses briefly about the literature review that consist of an introduction of induction motor and fuzzy logic theory.

Chapter 3 discusses about the methodology that explain about the developmental of project.

Chapter 4 gives an overview of the fuzzy logic controller. It discusses about the fuzzy sets, their operation and membership functions. It also provides the basic information about Fuzzy Logic Controllers (FLC), its various features and their functioning.

Chapter 5 is dedicated to the simulation of the induction motor torque control system in MATLAB/SIMULINK®. Both Fuzzy Logic Controller and conventional PI Controller have been used. The results obtained have been compared and discussed.

The last chapter is the conclusion in Chapter 8. This chapter also includes information about the future scope of the designed controller.



PTTA UTHM
PERPUSTAKAAN TUNJUKU AMINAH

CHAPTER 2

LITERATURE REVIEW

2.1 Induction Motor

The induction motor is the most commonly used type of ac motor. Its simple, rugged construction costs relatively little to manufacture. The induction motor has a rotor that is not connected to an external source of voltage. The induction motor derives its name from the fact that ac voltages are induced in the rotor circuit by the rotating magnetic field of the stator. In many ways, induction in this motor is similar to the induction between the primary and secondary windings of a transformer. Large motors and permanently mounted motors that drive loads at fairly constant speed are often induction motors. Examples are found in washing machines, refrigerator compressors, bench grinders, and table saws.

The stator construction of the three-phase induction motor and the three-phase synchronous motor are almost identical. However, their rotors are completely different (see Figure 2.1). The induction rotor is made of a laminated cylinder with slots in its surface. The windings in these slots are one of two types (shown in Figure 2.2). The most common is the squirrel-cage winding. This entire winding is made up of heavy copper bars connected together at each end by a metal ring made of copper or brass. No insulation is required between the core and the bars. This is because of the very low voltages generated in the rotor bars. The other type of winding contains actual coils placed in the rotor slots. The rotor is then called a wound rotor.

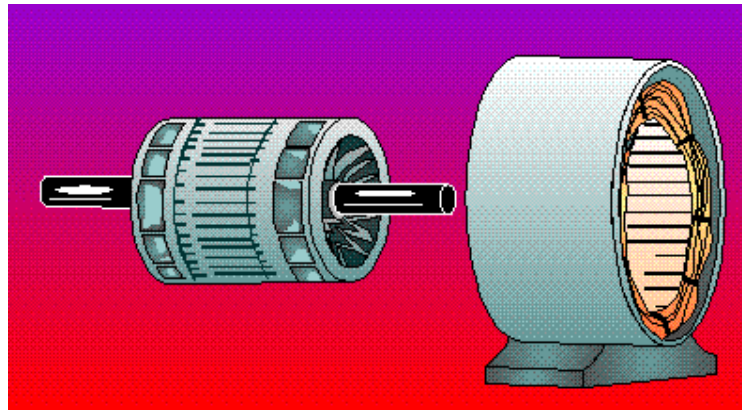

Figure 2.1 : Induction motor.

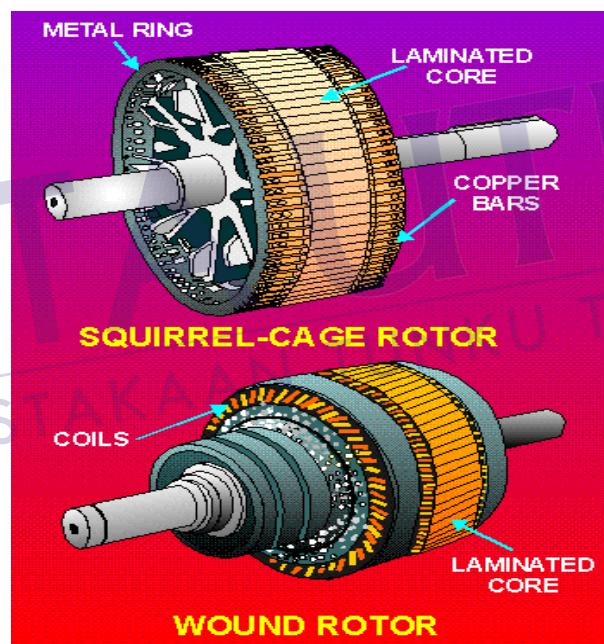

Figure 2.2 : Types of ac induction motor rotors

Regardless of the type of rotor used, the basic principle is the same. The rotating magnetic field generated in the stator induces a magnetic field in the rotor. The two fields interact and cause the rotor to turn. To obtain maximum interaction between the fields, the air gap between the rotor and stator is very small. As you know from Lenz's law, any induced emf tries to oppose the changing field that induces it. In the case of an induction motor, the changing field is the motion of the resultant stator field. A force is exerted on the rotor by the induced emf and the

resultant magnetic field. This force tends to cancel the relative motion between the rotor and the stator field. The rotor, as a result, moves in the same direction as the rotating stator field.

It is impossible for the rotor of an induction motor to turn at the same speed as the rotating magnetic field. If the speeds were the same, there would be no relative motion between the stator and rotor fields; without relative motion there would be no induced voltage in the rotor. In order for relative motion to exist between the two, the rotor must rotate at a speed slower than that of the rotating magnetic field. The difference between the speed of the rotating stator field and the rotor speed is called slip. The smaller the slip, the closer the rotor speed approaches the stator field speed. The speed of the rotor depends upon the torque requirements of the load. The bigger the load, the stronger the turning force needed to rotate the rotor. The turning force can increase only if the rotor-induced emf increases. This emf can increase only if the magnetic field cuts through the rotor at a faster rate. To increase the relative speed between the field and rotor, the rotor must slow down. Therefore, for heavier loads the induction motor turns slower than for lighter loads. The slip is directly proportional to the load on the motor. Actually only a slight change in speed is necessary to produce the usual current changes required for normal changes in load. This is because the rotor windings have such a low resistance. As a result, induction motors are called constant-speed motors.

2.2 Overloaded Motor

Overloaded motor is the electrical condition when a motor draws more current than it is rated to draw. When a motor draws current greater than full-load current continuously the motor windings may heat up beyond their temperature limits and consequently the winding insulation life expectancy may be shortened or even damage quickly. The motor overloaded is caused by:

- i. Low voltage from power grid - Low voltages can be due to “brown outs”, or “low voltage events”, which are system wide in the power grid. Low voltage events can occur when power grids are loaded to maximum, such as during severe cold spells, during the hottest days of the year, and during evening hours from 5:00 P.M. to 9:00 P.M.

- ii. Low voltage from local causes - Low voltages can also be caused by local system problems. Local system problems can be due to overloaded circuits in a building or on the site, undersized wire, or abnormal activity in the area overloading the power company's transformer or the feed wires to a site.

- iii. Low voltage due to poor design or installation - Low voltage can be caused by improper design or installation of the power circuit. Examples of this type of problem would be: wire size too small, loose connections or wire nuts, faulty circuit breakers or contactor points. Low voltage problems can also occur if the pump drive motor is designed for 1 type of voltage say for example 230 volts, but is being fed power from a 200 volt power supply.

Motor overload will lead to the motor overheated, cause the motor burning, and cause significant damage to the national economy. To prevent this happening, motors are widely used with overload protection technology.

2.3 Motor Torque

A motor must develop enough turning force to start a load and to keep it operating under normal conditions. The manufacturer designs an electric motor to produce adequate torque for different types of loads. A graph can be drawn of the torque developed by the motor at various rotor r/min , Figure 2.3. The *locked-rotor torque* is the torque available to get a load or machine started. This is one of the most important considerations when choosing a motor for a farm application. Single-phase motors are discussed later in this unit, from lowest to highest starting torque. The breakdown torque is not a consideration when selecting a motor. However, it is used by manufacturers in determining the rated horsepower of a motor. If the load torque requirement exceeds the breakdown torque, the motor will stall. A motor is designed to operate at the full-load torque. A continuous-duty motor will operate indefinitely at full-load torque without overheating. If the motor is oversized for the load, it will produce less than the full-load torque. If the motor is overloaded, it will develop more than the full-load torque. Look closely at Figure 2.3 and notice that the induction motor slows down when overloaded, and speeds up when under loaded.



Many single-phase motors have a starting winding that is disconnected when the motor achieves about three-quarters of operating r/min.

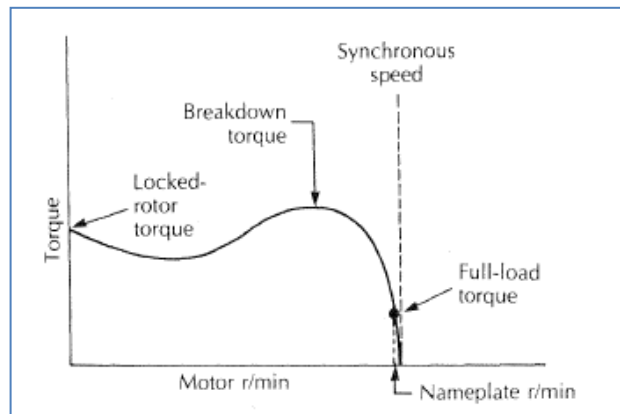

Figure 2.3 : Torque of three-phase motor

A centrifugal switch attached to the rotor shaft is often used to disconnect the starting winding. This switching point is easily noticeable on a single-phase induction motor torque-speed graph, Figure 2.4.

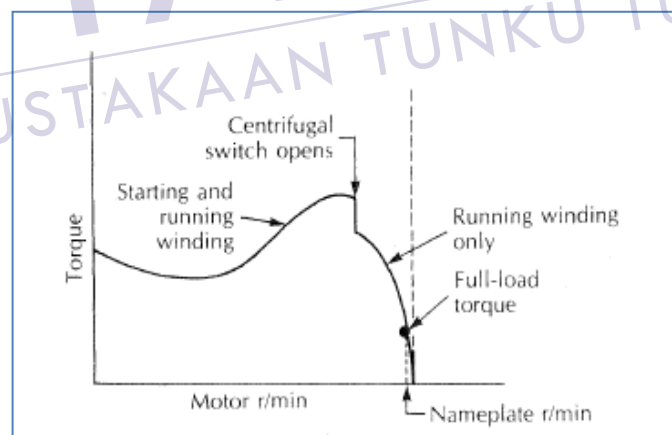

Figure 2.4 : Torque of single-phase motor as the rotor accelerates from zero to full speed.

2.4 Artificial Intelligence

Artificial intelligence (AI) is the intelligence of machines and the branch of computer science that aims to create it. AI textbooks define the field as "the study and design of intelligent agents" where an intelligent agent is a system that perceives its environment and takes actions that maximize its chances of success. John McCarthy, who coined the term in 1955, defines it as "the science and engineering of making intelligent machines."

AI research is highly technical and specialized, deeply divided into subfields that often fail to communicate with each other. Some of the division is due to social and cultural factors: subfields have grown up around particular institutions and the work of individual researchers. AI research is also divided by several technical issues. There are subfields which are focused on the solution of specific problems, on one of several possible approaches, on the use of widely differing tools and towards the accomplishment of particular applications. The central problems of AI include such traits as reasoning, knowledge, planning, learning, communication, perception and the ability to move and manipulate objects. General intelligence (or "strong AI") is still among the field's long term goals. Currently popular approaches include statistical methods, computational intelligence and traditional symbolic AI. There are an enormous number of tools used in AI, including versions of search and mathematical optimization, logic, methods based on probability and economics, and many others.

The field was founded on the claim that a central property of humans, intelligence—the sapience of *Homo sapiens*—can be so precisely described that it can be simulated by a machine. This raises philosophical issues about the nature of the mind and the ethics of creating artificial beings, issues which have been addressed by myth, fiction and philosophy since antiquity. Artificial intelligence has been the subject of optimism, but has also suffered setbacks and today, has become an essential part of the technology industry, providing the heavy lifting for many of the most difficult problems in computer science. Artificial intelligent techniques divide two groups: hard computation and soft computation. Expert system belongs to hard computation which has been the first artificial intelligent technique. In recent two decades, soft computation is used widely in electrical drives. They are:

- i. Artificial Neural Network (ANN)

- ii. Fuzzy Logic Set (FLS)
- iii. Fuzzy-Neural Network (FNN)
- iv. Genetic Algorithm Based system (GAB)
- v. Genetic Algorithm Assisted system (GAA)

Neural networks and fuzzy logic technique are quite different, and yet with unique capabilities useful in information processing by specifying mathematical relationships among numerous variables in a complex system, performing mappings with degree of imprecision, control of nonlinear system to a degree not possible with conventional linear systems.

2.5 Fuzzy Logic Controller

Fuzzy logic is a technique to embody human-like thinking into a control system. A fuzzy controller can be designed to emulate human deductive thinking, that is, the process people use to infer conclusions from what they know. Fuzzy control has been primarily applied to the control of processes through fuzzy linguistic descriptions. Fuzzy control system consists of four blocks as shown in Figure 2.5.

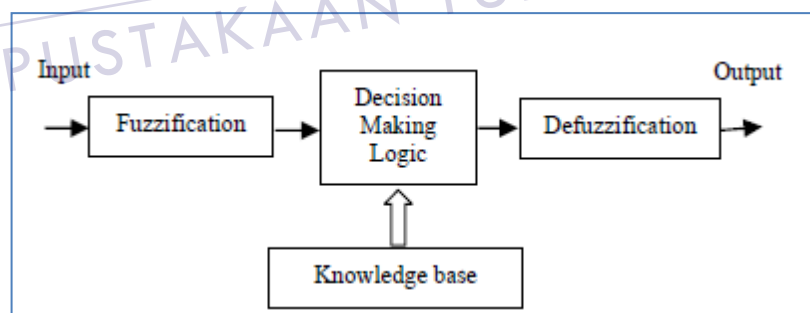

Figure 2.5 : Basic fuzzy logic control block diagram

To design a fuzzy controller based on human knowledge, there are several issues that have to be resolved. First, in many real world applications, human knowledge is not complete. That is, available human knowledge does not cover all possibilities of the status of a plant. Secondly, there are many applications that even human experts knowledge is not available, nor is a mathematical model of a plant.

2.6 Fuzzy Logic as an Evolutionary Computational Tool

Fuzzy logic, first introduced by Lotfi A. Zadeh ^[3] in 1965, embodies human-like thinking into a control system. A fuzzy controller employs a mode of approximate reasoning resembling the decision making route of humans, that is, the process people use to infer conclusions from what they know. Fuzzy control has been primarily applied to the control of processes through fuzzy linguistic descriptions stipulated by membership functions.

The conventional Boolean logic has been extended to deal with the concept of partial truth – truth values which exist between “completely true” and “completely false”, and what we shall be referring to as fuzzy logic ^[3]. This is achieved through the concept of degree of membership. The essence of fuzzy logic rests on a set of linguistic if-then rules, like a human operator. It has met a growing interest in many motor control applications due to its non-linearity handling features and independence of plant modeling. Moreover, the fuzzy logic concepts play a vital role in developing controllers for the plant since it isn't needy of the much complicated hardware and all it necessitates are only some set of rules.

2.7 Classical Set and Fuzzy Set: A Comparison

Let X be a space of objects (called universe of discourse or universal set) and be a generic element of X .

A classical set A (A is a subset of X), is defined as a collection of elements or objects $x \in X$, such that each x can either belong or not belong to the set A . By defining a characteristic function for each element x in X , we can represent the classical set A by a set of ordered pairs $(x, 0)$ or $(x, 1)$ which indicates or, respectively $x \in A$ or $x \notin A$.

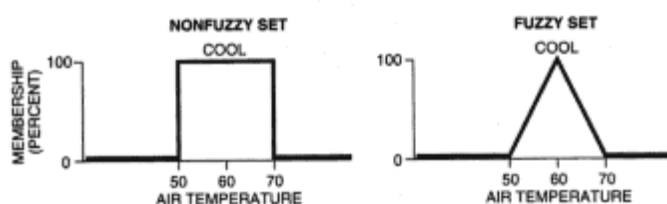

Figure 2.6 : Example of Classical Set and Fuzzy set

In spite of being an important tool for the engineering sciences, classical sets fail to replicate the nature of human conceptions, which tend to be abstract and vague. A fuzzy set ^[3] conveys the degree to which an element belongs to a set. In other words, if X is a collection of objects denoted generically by, then a fuzzy set A in X is defined as a set of ordered pairs:

$$A = \{(x, \mu_A(x)) \mid x \in X\} \quad (2.1)$$

where $\mu_A(x)$ is known as the *membership function* for the fuzzy set A . MF serves the purpose of mapping each element of X to a membership grade (or membership value) between 0 and 1. Clearly, if the value $\mu_A(x)$ of is restricted to either 0 or 1, then A is reduced to a classical set and $\mu_A(x)$ is the characteristic function of A .

2.8 Fuzzy Sets with a Continuous Universe

Let X is the set of possible ages for human beings. Then the fuzzy set $A =$ “about 50 years old” may be expressed as:

$$A = \{(x, \mu_A(x)) \mid x \in X\}$$

Where,

$$\mu_A(x) = \frac{1}{1 + \left(\frac{x-50}{10}\right)^4} \quad (2.2)$$

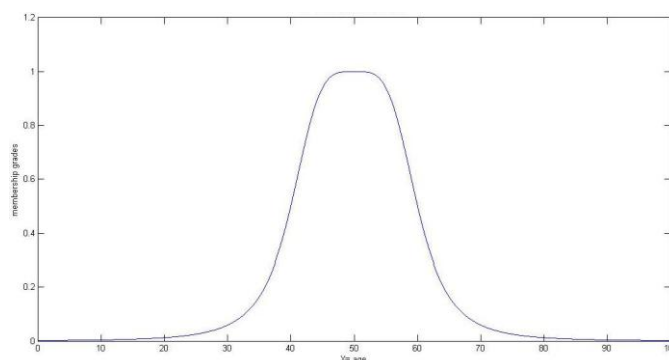

Figure 2.7 : Membership Function on a Continuous Universe

The aforementioned example clearly expresses the dependence of the construction of a fuzzy set on two things:

- i. Identifying a suitable universe of discourse.
- ii. Laying down a suitable membership function.

At this point, it is imperative to state that the specification of membership functions is *subjective*; meaning that membership functions stated for the same notion by different persons will tend to vary noticeably. Subjectivity and non-randomness differentiate the study of fuzzy sets from probability theory. Latter deals with tangible handling of random phenomena.

Crisp variable: A crisp variable is a physical variable that can be measured through instruments and can be assigned a crisp or discrete value, such as a temperature of 30 °C, an output voltage of 8.55 V etc.

Linguistic variable: When the universe of discourse is a continuous space, the common practice is to partition X into several fuzzy sets whose MFs cover X in a more or less uniform manner.

These fuzzy sets, which usually carry names that conform to adjectives appearing in our daily linguistic usage, such as “large”, “medium” or “small”, are called linguistic values. Consequently, the universe of discourse X is often called the linguistic variable.

2.9 Fuzzy Set-Theoretic Operations

The most elementary operations on classical sets include union, intersection and complement.

Analogous to these operations, fuzzy sets also have similar operations ^[3] which are explained below.

2.9.1 Containment or Subset

Fuzzy set A is contained in fuzzy set B (or, equivalently, A is a subset of B) if $\mu_A(x) \leq \mu_B(x)$ for all x . The following figure clarifies this concept.

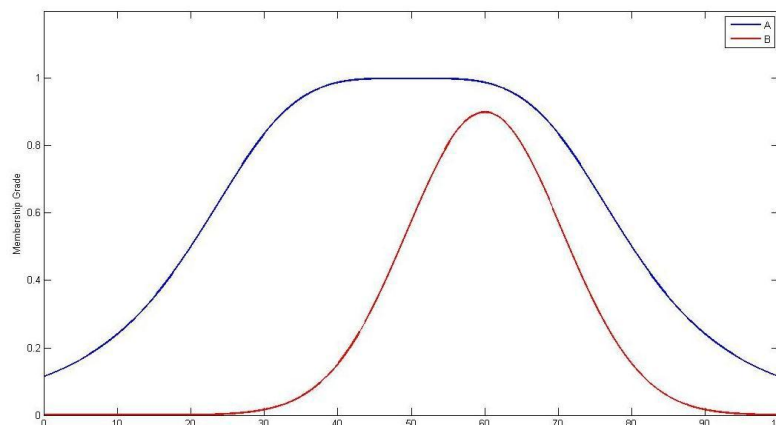

Figure 2.8 : The concept of containment or subset

2.9.2 Union (Disjunction)

The union of two fuzzy sets A and B is a fuzzy set C, written as $C = A \cup B$ or $C = A$ OR B, whose MF is related to those of A and B by:

$$\mu_C(x) = \max(\mu_A(x), \mu_B(x)) = \mu_A(x) \vee \mu_B(x) \quad (2.3)$$

Equivalently, union is the *smallest* fuzzy set containing both A and B. Then again, if D is any fuzzy set encompassing both A and B, then it also contains $A \cup B$. A union of two fuzzy sets A and B is shown in Figure 2.9 (b).

2.9.3 Intersection (Conjunction)

The intersection of two fuzzy sets A and B is a fuzzy set C, written as $C = A \cap B$ or $C = A$ AND B, whose MF is related to those of A and B by

$$\mu_C(x) = \min(\mu_A(x), \mu_B(x)) = \mu_A(x) \wedge \mu_B(x) \quad (2.4)$$

Analogous to the definition of union, intersection of A and B is the *largest* fuzzy set which is contained in both A and B. An intersection of two fuzzy sets A and B is shown in Figure 2.9(c).

2.9.4 Complement (Negation)

The complement of fuzzy set A, designated by \bar{A} ($\neg A$, NOT A), is defined as

$$\mu_{\bar{A}}(x) = 1 - \mu_A(x) \quad (2.5)$$

Fuzzy set A and its complement \bar{A} is shown in Figure 2.9(d).

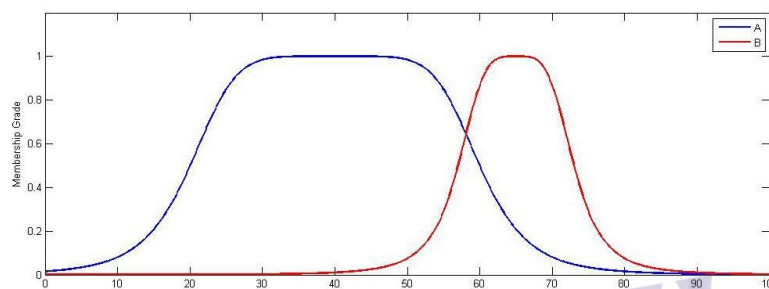

(a) Two Fuzzy sets A and B

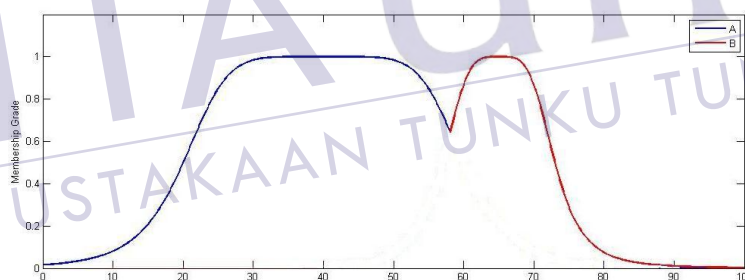

(b) $A \cup B$

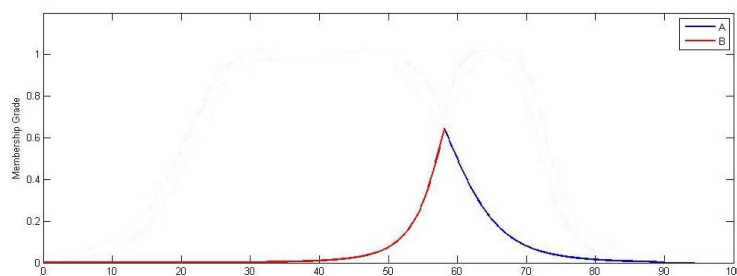

(c) $A \cap B$

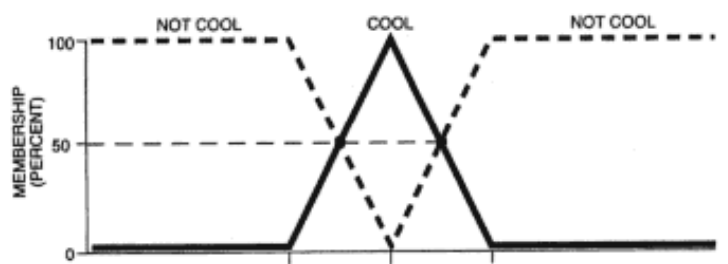

(d) Fuzzy set A and its complement \bar{A}

Figure 2.9 : Operations on Fuzzy sets

2.10 Formulating Membership Functions

Any membership function completely characterizes the fuzzy set that it belongs to. A convenient and succinct way to define an MF is to express it as a mathematical function. In order to define fuzzy membership function, designers choose many different shapes based on their preference and know-how. Different classes of parameterized membership functions ^[14] commonly used are:

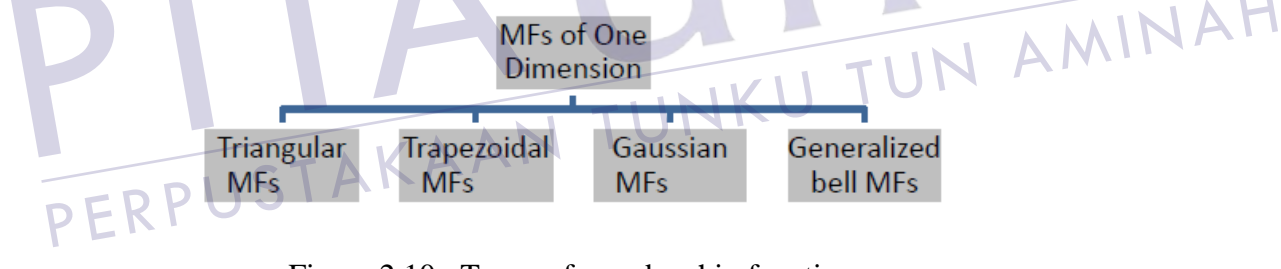

Figure 2.10 : Types of membership functions

Among the alternatives just mentioned, the most popularly used MFs in real-time implementations are triangular and trapezoidal because of the fact that these are easy to represent the designer's idea and require low computation time.

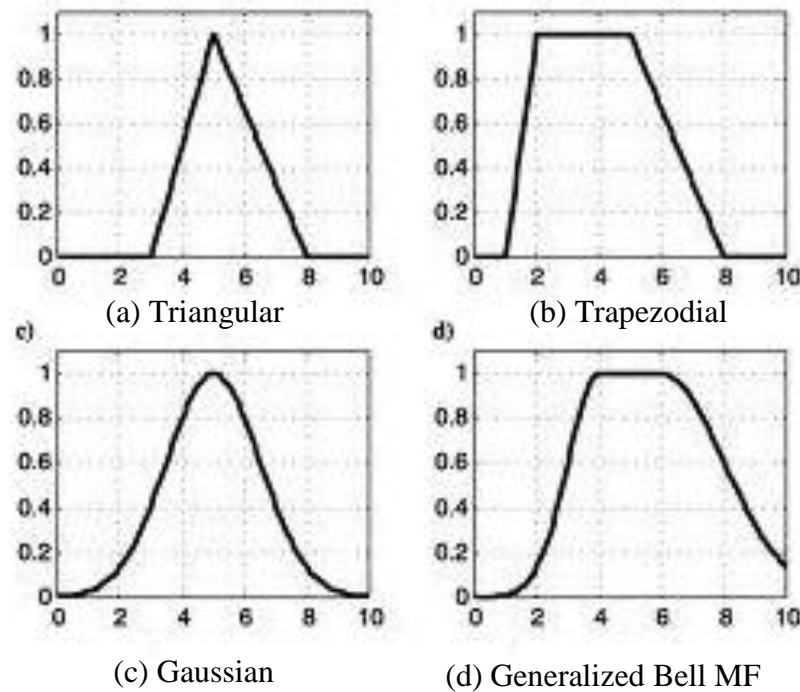

Figure 2.11 : Examples of four classes of parameterized MFs

2.11 Summary

This chapter throws light upon some of the basics of induction motor, which include its constructional details, working and in particular its pluses over conventional dc motors. It is a singly-fed motor unlike the synchronous motor which calls for ac supply on the stator side and dc excitation on the rotor. The torque developed in this motor originates from current induced in the rotor which is only feasible at non-synchronous speed; hence it is also known as *asynchronous* machine.

This chapter also defines the necessity of fuzzy logic, introduces fuzzy sets and corresponding set operations (AND, OR, and NOT), as well as describes membership function representations and their types. A fuzzy set is a set without a crisp periphery. That is, the switch from “belong to a set” to “not belong to a set” is steady, and this smooth transition is characterized by membership functions that give fuzzy sets flexibility in modeling universally used linguistic expressions. These sets^[14] play a significant role in human thinking, particularly in the domains of pattern recognition, communication of information and perception. Fuzziness does not come from the randomness of the constituent members of the sets, but from the uncertain and imprecise nature of abstract thoughts and concepts. Fuzzy set is simply an

extension of a classical set in which the characteristic function is allowed to have values between 0 and 1, which denotes the degree of membership of an element in a given set. The specification of membership functions is subjective, which comes from individual differences in perceiving nonconcrete models. The *universe of discourse* may consist of discrete objects or continuous space, which is totally covered by the MFs and the transition from one MF to another, is smooth and gradual. The union, intersection and negation operations perform exactly as that for crisp sets if the values of the membership functions are restricted to either 0 or 1.



PTTA UTHM
PERPUSTAKAAN TUNKU TUN AMINAH

CHAPTER 3

METHODOLOGY

3.1 Project Methodology

This chapter will be divided into three phases. The first phase is to understand the torque control method. The second phase understands the fuzzy logic controller method and its algorithm. The last phase is to develop a smart torque control for overloaded motor using artificial intelligence.

3.2 Literature reviews on previous works in torque control method

In applications of high-performance motor drives such as motion control, it is usually desirable that the motor can provide good dynamic torque response as is obtained from dc motor drives. Many control schemes have been proposed for this goal.

3.2.1 Field Oriented Control

Vector control or sometimes called field oriented control has been recognized as one of the most effective methods. It is well known that vector control needs quite complicated coordinate transforms on line to decouple the interaction between flux control and torque control to provide fast torque control of induction motor. Hence the algorithm computation is time consuming and its implementation usually requires using a high performance DSP chip [2].

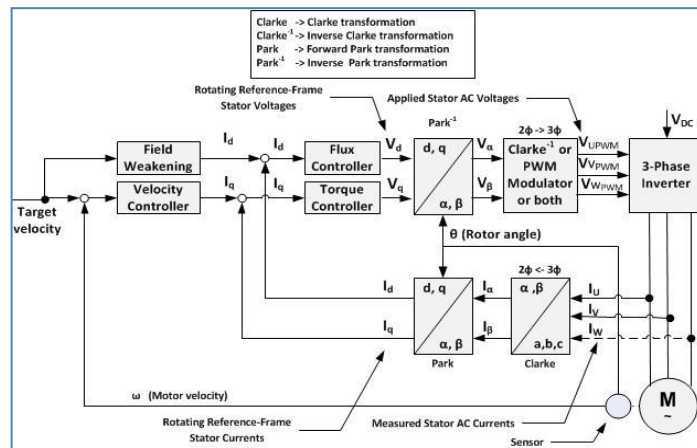

Figure 3.1 : Field oriented control scheme for motor drives

3.2.2 Direct Torque Control (DTC)

In recent years an innovative control method called direct torque control (DTC) has gained the attraction of researchers, because it can also produce fast torque control of the induction motor and does not need heavy computation on-line, in contrast to vector control. Basically direct torque control employs two hysteresis controllers to regulate stator flux and developed torque respectively, to obtain approximately decoupling of the flux and torque control. The key issue of design of the DTC is the strategy of how to select the proper stator voltage vector to force stator flux and developed torque into their prescribed band. The hysteresis controller is usually a two-value bang-bang controller, which results in taking the same action for the big torque error and small torque error. Thus it may produce big torque ripple. In order to improve the performance of the DTC it is natural to divide torque error into several intervals, on which different control action is; taken. As the DTC control strategy is not based on mathematical analysis, it is not easy to give an apparent boundary to the division of torque error [5].

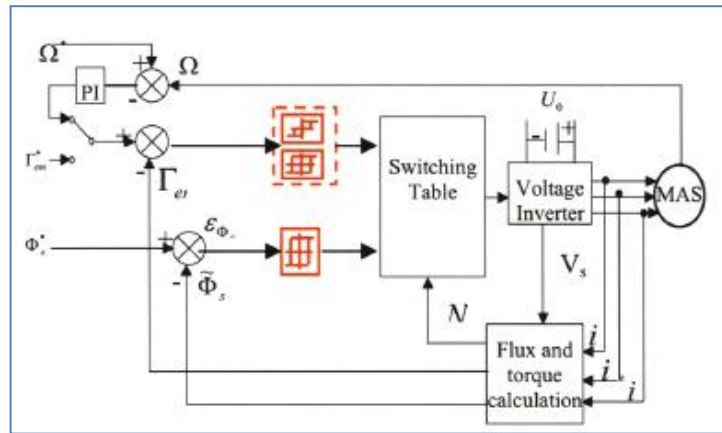

Figure 3.2 : Basic direct torque control scheme for motor drives

3.3 Fuzzy Logic Control

Fuzzy control is a way for controlling a system without the need of knowing the plant mathematic model. It uses the experience of people's knowledge to form its control rule base. There have appeared many applications of fuzzy control on power electronic and motion control in the past few years [6]. A fuzzy logic controller was reported being used with DTC. However there arises the problem that the rule numbers it used is too many which would affect the speed of the fuzzy reasoning. In this paper a comparison of various strategy of direct torque control of induction motors is used to improve the performance of DTC scheme. The control algorithm is based on the SVM technique to provide a constant inverter switching frequency and reduced flux and torque ripple and current distortion. A space vector is generated by two fuzzy logic controllers associated with hysteresis regulators. The first one is to control flux and the other to control torque. The use of fuzzy controllers permits a faster response and more robustness.

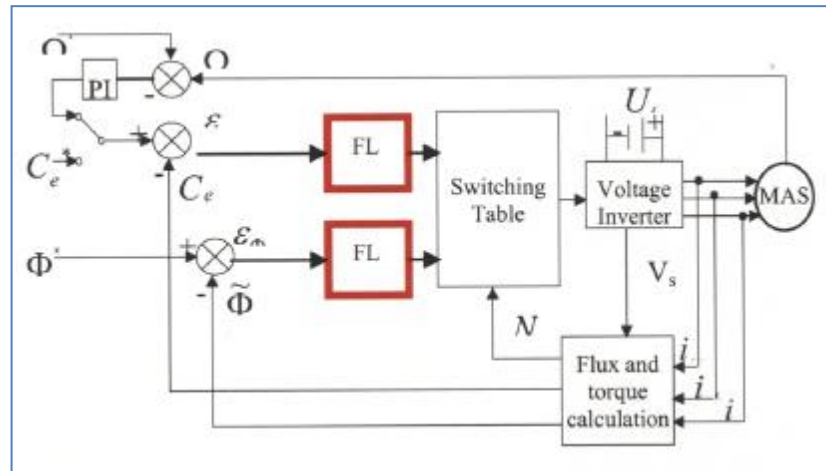

Figure 3.3 : Basic fuzzy logic control scheme for motor drives

3.4 Design fuzzy logic controller method and its algorithm

Fuzzy logic is the theory of fuzzy sets, sets that calibrate vagueness. A fuzzy control system consists of the following components and its block diagram is shown in Figure

3.4.

- i. A rule-base (a set of If-Then rules), which contains a fuzzy logic quantification of the expert's linguistic description of how to achieve good control.
- ii. An inference mechanism (also called an "inference engine" or "fuzzy inference" module), which emulates the expert's decision making in interpreting and applying knowledge about how best to control the plant.
- iii. A fuzzification interface, which converts controller inputs into information that the inference mechanism can easily use to activate and apply rules.
- iv. A defuzzification interface, which converts the conclusions of the inference mechanism into actual inputs for the process.

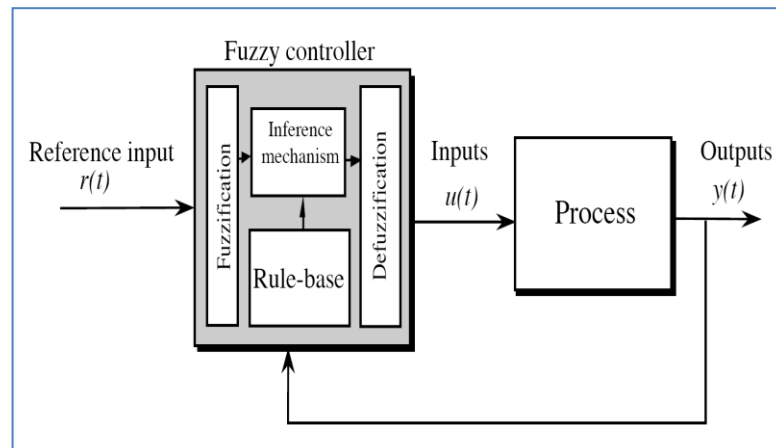

Figure 3.4 : Fuzzy controller block diagram

The controller can be used with the process in two modes:

- i. feedback mode when the fuzzy controller will act as a control device;
- ii. feed forward mode where the controller can be used as a prediction device.

All inputs to, and outputs from, the controller are in the form of linguistic variables. In many ways, a fuzzy controller maps the input variables into a set of output linguistic variables. Process of developing a fuzzy logic controller involves five steps:

Step 1 : Specify the problem; define linguistic variables.

Step 2 : Determine fuzzy sets.

Step 3 : Elicit and construct fuzzy rules.

Step 4 : Encode the fuzzy sets, fuzzy rules and procedures to perform fuzzy inference into the expert system.

Step 5 : Evaluate and tune the system.

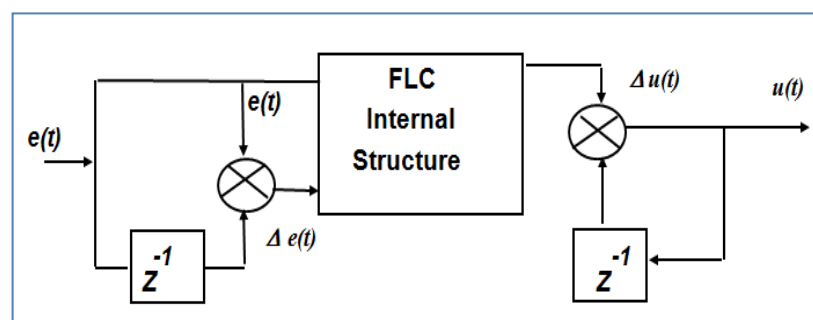

Figure 3.5 : Fuzzy logic based control system

3.5 Develop a smart torque control for overloaded motor using artificial intelligence.

The controllers that have been designed will be simulated. The simulation work will be carried out on MATLAB platform with Simulink as its user interface.



PTTA UTHM
PERPUSTAKAAN TUNKU TUN AMINAH

REFERENCES

- 1 A.Balakrishnan and T.Vasanth. (2008). "Electrical Machine 1.". Malaysia : IBSBuku Sdn. Bhd.
- 2 Lamia, Y and Aurelian, T. (2007). "A Comparison of Various Strategies for Direct Torque Control of Induction Motors." *International Conference on Computer, Electrical, and Systems Science, and Engineering, Prague, Republic Czech.*
- 3 Yang, X. and Wardina, O. (1991). "Study on Fuzzy Control of Induction Machine with Direct Control Approach." Centre for Railway Engineering, Central Queensland University.
- 4 Srinivasa, K. And Tulasi, R. (2010). "Improvement in Direct Torque Control of Indiction Motor using Fuzzy Logic Duty Ratio Controller." School of Electrical Engineering, Vignan University, Vadlamudi, A. P., India
- 5 Xiao, H.H, Li., S., Wan, P.L. and Zhao, M.F. (2002). "Study on Fuzzy Direct Torque Control System." Department of Electronic Engineering, Chongqing Institute of Technology.
- 6 L. A. Zadeh. "Fuzzy sets." *Information and Control*, 8(3):338-353, 1965.
- 7 R.Ouiguini, K. Djeflal, A.Oussedik and R. Megartsi, "Speed Control of an Induction Motor using the Fuzzy logic approach.", *ISIE'97 - Guimariies, Portugal*, IEEE Catalog Number: 97TH8280, vol.3, pg. 1168 – 1172.
- 8 Yau-Tze Kao and Chang-Huan Liu, "Analysis and Design of Microprocessor-Based Vector-Controlled Induction Motor Drives," *IEEE Transactions on Industrial Electronics*, Vol. 39, pp. 46 – 54, 1 February, 1992.
- 9 M.Chow, A. Menozzi and F. Holcomb , "On the Comparison of Emerging and Conventional Techniques for DC Motor Control," *proc. IECON* , pp. 1008 1013, 1992.

- 10 Abdullah I. Al-Odienat, Ayman A. Al-Lawama, "The Advantages of PID Fuzzy Controllers Over The Conventional Types," American Journal of Applied Sciences 5 (6): 653-658, 2008, ISSN 1546-9239, pp. 653 – 658.
- 11 Gopal K. Dubey, "Fundamentals of Electrical Drives", Narosa Publishing House Pvt. Ltd., 2001, chap. 6.
- 12 J. Martínez García, J.A. Domínguez, "Comparison between Fuzzy logic and PI controls in a Speed scalar control of an induction machine," CIRCE – ge3 – Departamento de Ingeniería Eléctrica C.P.S., Universidad de Zaragoza, Conf. Paper.
- 13 D. P. Kothari, I. J. Nagrath, "Electric Machines", Tata McGraw – Hill Education Private Limited, ISBN-13: 978-0-07-058377-1, ISBN-10: 0-07-058377-3, 2004, chap. 9.
- 14 J.-S. R. Jang, C.-T. Sun, E. Mizutani, "Neuro-Fuzzy and Soft Computing," Pearson Education Pte. Ltd., ISBN 81-297-0324-6, 1997, chap. 2, chap. 3, chap. 4.
- 15 I. J. Nagrath, M. Gopal, "Control Systems Engineering", New Age International Publishers, 2007, chap. 3.
- 16 MATLAB/SIMULINK® version 2009a, The MathWorks Inc., USA
- 17 Fuzzy Inference Systems reference manual for MATLAB/SIMULINK® version 2009a.
- 18 S. Mir, D. Zinger and M. Elbuluk, "Fuzzy controller for inverter-fed induction machine," IEEE Trans. Ind. Appl., vol. 30, 1994, no. 1, pp. 78-84.

