

INFLUENCE OF SPEED AND FLOW RATE ON ROAD ACCIDENTS: A CASE  
STUDY ALONG FEDERAL ROUTE 50 (FT 050)

HOR PEAY SAN

A thesis submitted in  
fulfillment of the requirement for the award of the  
Degree of Master of Civil Engineering



PTTAUTHM  
PERPUSTAKAAN TUNKU TUN AMINAH

Faculty of Civil and Environmental Engineering  
Universiti Tun Hussein Onn Malaysia

AUGUST 2013

## ABSTRACT

Federal Route 50 (FT 050) has an annual average daily traffic (AADT) of more than 68,000 vehicles daily at the Batu Pahat-Parit Raja stretch and above 22,000 vehicles daily at the Ayer Hitam-Parit Raja stretch in 2010. During peak hours, the traffic volume could even go beyond 9,000 veh/hr at certain sections. Works Ministry of Malaysia (KKR) reported that Federal Route 50 (FT 050) had been identified as the “deadliest stretch of road” in Malaysia. The road recorded more than an average of 1,000 accidents and 36 deaths annually since 2006. This research aims to study the effects of speed and flow rate on road accidents at selected sections along Federal Route 50 (FT 050), which each has different road characteristics. Spot speed study was carried out at KM 5, KM 10, KM 15, KM 20, KM 25 and KM 30 to evaluate the influence of speed upon road accidents, while traffic volume count was conducted at KM 5, KM 20 and KM 30 to identify the effect of flow rate upon road accidents. Besides that, site observation was also conducted at the selected sections, where road facilities and countermeasures were studied generally. A model produced using multiple regression analysis technique with backward method shows that road accident frequency increases with the increase of flow rate. The model estimates that every 200 pc/hr/lane increases accident frequency by about 9 acc/yr. On the other hand, speed relates to accident as an effect of flow rate. By categorising the sections of FT 050 into 3 different zones based on the frequency of road accidents, results reveal that road accidents frequency increases with speed at different rates.



## ABSTRAK

Jalan Persekutuan 50 (FT 050) mempunyai purata trafik harian tahunan yang melebihi 68,000 kenderaan sehari di laluan Batu Pahat-Parit Raja dan melebihi 22,000 kenderaan sehari di laluan Ayer Hitam-Parit Raja pada tahun 2010. Pada waktu puncak, isipadu trafik boleh mencecah 9,000 kenderaan/jam di sesetengah seksyen. Kementerian Kerja Raya Malaysia telah melaporkan bahawa Jalan Persekutuan 50 (FT 050) telah dikenal pasti sebagai “jalan maut” di Malaysia. Secara puratanya, jalan ini mencatatkan lebih daripada 1,000 kemalangan dan 36 kematian setiap tahun sejak 2006. Tujuan kajian ini ialah mengkaji kesan kelajuan dan kadar aliran ke atas kemalangan jalan raya di seksyen yang terpilih sepanjang Jalan Persekutuan 50 (FT 050), yang mana setiapnya mempunyai ciri-ciri jalan yang berbeza. Kajian kelajuan kenderaan telah dijalankan di KM 5, KM 10, KM 15, KM 20, KM 25 dan KM 30 untuk menilai pengaruh kelajuan ke atas kemalangan jalan raya, manakala kiraan isipadu trafik telah dijalankan di KM 5, KM 20 dan KM 30 untuk mengenal pasti kesan kadar aliran ke atas jalan raya. Selain itu, pemerhatian di tapak juga dilakukan di seksyen yang terpilih, di mana kemudahan dan dikaji secara umumnya. Satu model yang dihasilkan menggunakan *multiple regression analysis technique* dengan kaedah *backward* menunjukkan bahawa kekerapan kemalangan jalan raya bertambah dengan peningkatan aliran isipadu kenderaan. Model tersebut menganggarkan bahawa setiap 200 *pc/hr/lane* akan meningkatkan kekerapan kemalangan jalan raya sebanyak 9 kemalangan setahun. Kelajuan pula mempengaruhi kekerapan kemalangan jalan raya akibat daripada kesan kadar aliran. Dengan mengkategorikan seksyen-seksyen di FT 050 kepada 3 zon yang berbeza berdasarkan kekerapan kemalangan jalan raya, keputusan menunjukkan bahawa kekerapan kemalangan jalan raya meningkat dengan kelajuan pada kadar yang berbeza.

## CONTENTS

	<b>TITLE</b>	<b>i</b>
	<b>DECLARATION</b>	<b>ii</b>
	<b>DEDICATION</b>	<b>iii</b>
	<b>ACKNOWLEDGEMENT</b>	<b>iv</b>
	<b>ABSTRACT</b>	<b>v</b>
	<b>ABSTRAK</b>	<b>vi</b>
	<b>CONTENTS</b>	<b>vii</b>
	<b>LIST OF TABLES</b>	<b>x</b>
	<b>LIST OF FIGURES</b>	<b>xi</b>
	<b>LIST OF SYMBOLS AND ABBREVIATIONS</b>	<b>xiv</b>
	<b>LIST OF APPENDICES</b>	<b>xvi</b>
<b>CHAPTER 1</b>	<b>INTRODUCTION</b>	<b>1</b>
	1.1 Introduction	1
	1.2 Aim and objectives of research	4
	1.3 Scope of study	4
	1.4 Structure of thesis	5
<b>CHAPTER 2</b>	<b>LITERATURE REVIEW</b>	<b>7</b>
	2.1 Introduction	7
	2.2 Road accident factors	7
	2.2.1 Human factors	8
	2.2.2 Road and environment factors	9
	2.2.3 Vehicle factors	10
	2.3 Road design standards and road categories in Malaysia	10
	2.4 Geometric design of roads	14
	2.4.1 Sight distance	14
	2.4.2 Horizontal alignment	16



2.4.3	Vertical alignment	19
2.5	Overview of road accidents in Malaysia	22
2.6	Influence of speed on road accidents	24
2.6.1	Speed and accident severity	25
2.6.2	Speed and accident involvement	26
2.6.3	The role of speed variance	28
2.6.4	Speed and accidents involving killed and serious injury (KSI) cases	28
2.6.5	Speed and accidents on different road types	29
2.7	Influence of traffic volume on road accidents	33
2.8	Accident prediction models	36
2.8.1	Establishing prediction models using various methods	37
2.8.2	Accident prediction models for different types of areas	39
2.9	Summary	42
<b>CHAPTER 3 RESEARCH METHODOLOGY</b>		<b>43</b>
3.1	Introduction	43
3.2	Data collection	45
3.2.1	Accident data	45
3.2.2	Maps	45
3.3	Analysis of accident data	46
3.4	Site investigation	46
3.4.1	Initial site visit	46
3.4.2	Site studies and analysis	47
3.5	Data analysis	52
3.5.1	Regression analysis	52
3.5.2	Chi-squared test	52
3.5.3	Coefficient of determination ( $R^2$ value)	53
3.5.4	Mapping	53
<b>CHAPTER 4 RESULTS AND ANALYSIS</b>		<b>55</b>
4.1	Introduction	55
4.2	Accident trend and statistics at Federal Route 50	55



4.3	Traffic volume studies	63
4.4	Speed investigation	67
4.5	Zoning FT 050	69
4.5.1	Zone A	70
4.5.2	Zone B	72
4.5.3	Zone C	75
4.6	Relationship among variables	76
4.6.1	Relationship between flow rate and accident	77
4.6.2	Relationship between 85th percentile speed and flow rate	80
4.6.3	Relationship between 85th percentile speed and accidents	81
4.7	Accident prediction model	84
4.8	Mapping	85
4.9	Road accident countermeasures	88
4.9.1	Countermeasures for pedestrians	88
4.9.2	Speed reduction countermeasures	89
4.9.3	Central median	91
<b>CHAPTER 5</b>	<b>CONCLUSION AND RECOMMENDATION</b>	<b>92</b>
5.1	Introduction	92
5.2	Conclusion of study	92
5.3	Recommendations for future studies	93
	<b>REFERENCES</b>	<b>94</b>
	<b>APPENDIX</b>	<b>99</b>



## LIST OF TABLES

2.1	Characteristics of road categories	12
2.2	Design speed for roads for rural roads	13
2.3	Design speed for urban roads	13
2.4	Minimum stopping sight distance	15
2.5	Minimum passing sight distance	16
2.6	Minimum radius for simple curves design	17
2.7a	Maximum grades for R1, R2, U1 and U2 standard roads	20
2.7b	Maximum grades for R3 and R4 standard roads	20
2.7c	Maximum grades for U3 and U4 standard roads	20
2.7d	Maximum grades for R5 standard roads	21
2.7e	Maximum grades for U5 standard roads	21
2.7f	Maximum grades for R1, R2, U1 and U2 standard roads	21
2.8	Minimum k values for vertical curve design	22
2.9	Description of road categories by Greibe	41
3.1	Passenger-car equivalents on extended general highway segments	51
4.1	Peak hour traffic volume at selected sections	63
4.2	Speed observation of selected sections at FT 050	68
4.3	Correlation amongst variables	77



## LIST OF FIGURES

1.1	Federal Route 50 being two-lane undivided roadway before upgrade	2
1.2	Average annual daily traffic at FT 050	3
1.3	Killer stretches in Johor	4
1.4	Map of FT 050 from KM 1 to KM 30	5
2.1	Road accident factors	8
2.2	Layout of a simple horizontal curve	17
2.3	Layout of a compound curve	18
2.4	Layout of a reverse curve with parallel tangents	18
2.5	Layout of a spiral curve	19
2.6	Types of vertical curves	20
2.7	Total road accidents and motor vehicles involved	23
2.8	Total casualties and deaths caused by road accidents, 2001-2010	24
2.9	Probability of death for drivers in car-to-car accidents	26
2.10	Relationship between speed and relative accident involvement, as found in different studies	27
2.11	Accident frequency against mean speed for urban road groups	30
2.12	Accident frequency against proportion of speeders for urban roads	31
2.13	Fatality units against percentage of vehicles above 90 km/h speed limit	32
2.14	Speed-accident relationship by road group	33
2.15	Accident number and traffic flow versus time of day for 1997 and 1998	34



2.16	Number of accidents per kilometer for each motorway section versus average hourly traffic flow over 1 year	35
2.17	Number of accidents per number of lanes versus hourly traffic flow	36
2.18	Accidents per km per year as a function of the AADT for six urban road types	40
3.1	Flow chart of research methodology	44
3.2	Radar gun used to measure speed of vehicles	48
3.3	Measuring speed of vehicles at site	48
3.4	Tally counter used for traffic volume counts	49
3.5	Layers of spatial data used for developing the database	54
3.6	Entering attribute data for developing the database	54
4.1	Accident frequency at FT 050, 2004-2011	56
4.2	Breakdown of road accidents at FT 050 by year	56
4.3	Road accidents according to seriousness at FT 050	57
4.4	Breakdown of road accidents according to seriousness at FT 050 by year	58
4.5	Total of killed and severely injured accidents at FT 050	59
4.6	Breakdown of KSI accidents at FT 050 by section	60
4.7	Road accident frequency and AWP at FT 050	61
4.8	Accident frequency and accident costs at each section of FT 050	62
4.9	Peak hour traffic volume at KM 5	64
4.10	Peak hour traffic volume at KM 20	65
4.11	Peak hour traffic volume at KM 30	65
4.12	Average peak hours traffic volume	66
4.13	Vehicle composition at selected sections	67
4.14	85 <sup>th</sup> percentile speed at selected sections	69
4.15	Different zones at FT 050	70
4.16	Accident frequency at Zone A sections	71
4.17	Accident frequency at Zone B sections	72
4.18	The junction outside Sharp-Roxy at KM 10	73



PERPUSTAKAAN TUNKU TUNJUNGINAH

4.19	A dangerous turning manoeuvre by a car at KM 22	74
4.20	Accident frequency at Zone C sections	75
4.21	Accident frequency and flow rate at FT 050	78
4.22	Relationship between accident frequency and flow rate	79
4.23	AWP and flow rate at FT 050	79
4.24	Relationship between average AWP and flow rate	80
4.25	Relationship between 85 <sup>th</sup> percentile speed and flow rate	81
4.26	Relationship between average accident frequency and 85 <sup>th</sup> percentile speed	82
4.27	Relationship between AWP and 85 <sup>th</sup> percentile speed	82
4.28	Relationship between accident frequency and 85 <sup>th</sup> percentile speed	84
4.29	Thematic map	86
4.30	Tabular display	86
4.31	Data display with pictures	87
4.32	Conditional data display	87
4.33	Overhead bridge near a school and factory at KM 5	89
4.34	Overhead bridge outside a shopping mall at KM 5	89
4.35	Rumble strips before a pedestrian crossing	90
4.36	Various speed limits at different sections	90
4.37	Warning signs found along FT 050	91
4.38	Central median at KM 5	91



PTPTA UTHM  
PERPUSTAKAAN TUNKU TUNAMINAH

## LIST OF SYMBOLS AND ABBREVIATIONS

ADT	-	Average Daily Traffic
AWP	-	Accident Weightage Point
$c_v$	-	Coefficient of Variation
est.	-	Estimate
FHWA	-	Federal Highway Administration
FT 050	-	Federal Route 50
HCM 2000	-	Highway Capacity Manual 2000
IPTHO	-	Institut Perguruan Tun Hussein Onn
JKJR	-	Jabatan Keselamatan Jalan Raya
JKR	-	Jabatan Kerja Raya
km/h	-	kilometre per hour
KKR	-	Kementerian Kerja Raya
MIROS	-	Malaysian Institute of Road Safety Research
MOT	-	Ministry of Transport Malaysia
PDRM	-	Polis Diraja Malaysia
pc/hr/ln	-	Passenger cars per hour per lane
PHF	-	Peak Hour Factor
PLUS	-	Projek Lebuhraya Utara-Selatan
$R^2$	-	Coefficient of Determination
REAM	-	Road Engineering Association of Malaysia
RTA	-	Roads and Transport Authority
RV	-	Recreational Vehicle
TRB	-	Transportation Research Board
TRL	-	Transport Research Laboratory
UPM	-	Universiti Putra Malaysia
UK	-	United Kingdom

**LIST OF APPENDICES**

<b>APPENDIX</b>	<b>TITLE</b>	<b>PAGE</b>
A	Accident Data	99
B	Maps	114
C	Spot Speed Data	117
D	Traffic Volume Data	124
E	Data Analysis	143
F	Statistical Analysis and Model Development	151



**PTTA UTHM**  
PERPUSTAKAAN TUNKU TUN AMINAH

## CHAPTER 1

### INTRODUCTION

#### 1.1 Introduction

Federal Route 50 (FT 050) is the major road that connects two major towns in Johor, namely Batu Pahat and Kluang, which is 52 km apart. Most part of the road was mainly built under the JKR R5 road standard, allowing a maximum speed of up to 100 km/h, though the speed limit set for this route is 90 km/h. It functions as primary road with partial access control.

Along the highway are housing areas, schools, industrial zones where local and multinational companies operate, shopping complexes, institutions of higher learning, business parks, sub-urban areas and oil palm plantations. It is also one of the main roads that connect the town of Batu Pahat to the North-South Expressway (PLUS) via Ayer Hitam exit. Interior areas in the district of Batu Pahat are likewise connected to the main town via Federal Route 50 (FT 050) Jalan Kluang.

The district of Batu Pahat has a population of more than 400, 000 residents, thus placing it as the 16<sup>th</sup> most populated urban area in Malaysia (Dept. of Statistics, 2011). Being the main road in the Batu Pahat district, Federal Route 50 (FT 050) Jalan Kluang connects the residents in the sub-urban areas i.e. Parit Besar, Parit Yaani, Seri Gading, Parit Raja, Ayer Hitam, etc. to the main town.

Growth in small and medium industries such as garments, textiles, electronics and confectionary along the years helped to boost development. Batu Pahat was upgraded to town status (Majlis Perbandaran) in 2001, alongside Muar, Kluang and



Skudai. International companies like Sharp Roxy, Sony, Fujitsu and Hitachi are operating in the industrial zones in Batu Pahat.

The district of Batu Pahat is also becoming well known as an education hub with a few institutions of learning established here. Among them are institutions of higher learning i.e. Universiti Tun Hussein Onn Malaysia, Institut Perguruan Tun Hussein Onn (IPTHO) and Kolej Kemahiran Tinggi MARA; a nursing school and a few primary and secondary schools.

The rapid development in Batu Pahat and its surrounding areas had drawn more and more people to the district and this led to increased travelling from the sub-urban areas to the city and vice-versa. Nowadays, Batu Pahat enjoys the name of "Northern Johor Shopping Paradise" due to the rapid development of those shopping malls and hypermarkets. All these made Federal Route 50 (FT 050) to be a very important road which connects the sub-urban areas to the main town. To meet the need of growing number of road users, the road was upgraded from a two-lane undivided roadway (as shown in Figure 1.1) to a four-lane undivided roadway. The upgrading project began in February 2002 and completed in August 2004. It is currently completing another phase of upgrade, where a divider is being built along the roadway from KM 3 to KM 20.

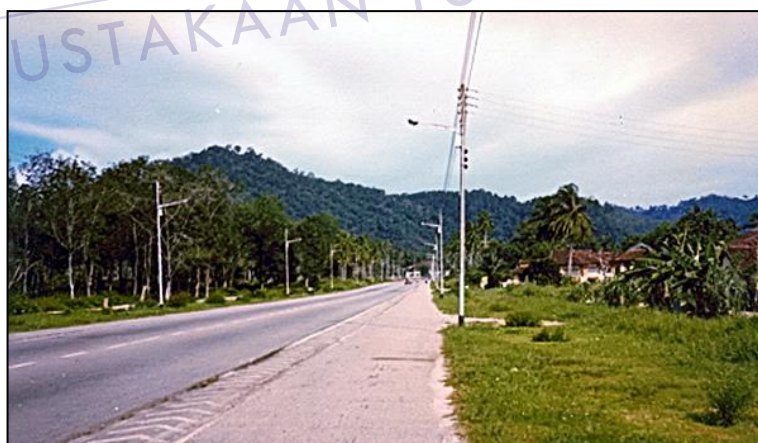

Figure 1.1: Federal Route 50 being two-lane undivided roadway before upgrade  
([www.batupahat.org](http://www.batupahat.org))

Federal Route 50 (FT 050) had an annual average daily traffic (AADT) of more than 68,000 vehicles daily at the Batu Pahat-Parit Raja stretch and above 22,000 vehicles daily at the Ayer Hitam-Parit Raja stretch in 2010. During peak

hours, the traffic volume could even go beyond 9,000 veh/hr at certain sections, as shown in Figure 1.2.

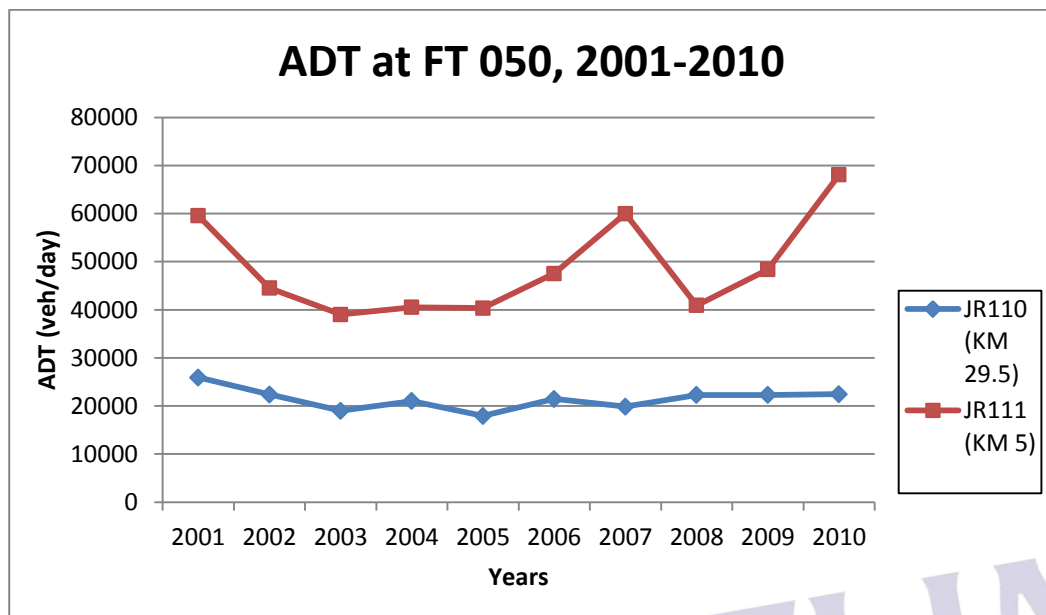

Figure 1.2: Annual average daily traffic at FT 050 (adapted from Highway Planning Unit, 2011)

As shown in Figure 1.3, *The Star* newspaper reported on 5 May 2009, that Federal Route 50 (FT 050) had been identified as the “deadliest stretch of road” in Malaysia, as announced by the Works Ministry of Malaysia (KKR). The stretch recorded more than an average of 1,000 accidents and 36 deaths annually since 2006.

Many researches had been conducted in the past to study the trend and factors affecting road accidents along Federal Route 50 (FT 050) but the majority of the studies were conducted in a few continuous sections only.



Figure 1.3: Killer stretches in Johor (The Star, 2009)

## 1.2 Aim and objectives of the research

The aim of the research is to evaluate the effects of speed and flow rate on road accidents along Federal Route 50 (FT 050).

The following are the objectives of the research:

- a) To correlate speed and flow rate with road accidents along FT 050.
- b) To produce an accident prediction model that can predict accident frequency based on selected variables.
- c) To produce road accident intensity map based on collected existing accident data.

## 1.3 Scope of study

This research focuses on section KM 1 to KM 30 of Federal Route 50 (FT 050) from Bandar Penggaram to Ayer Hitam only, as shown in Figure 1.4. Some of the



institutions found along the stretch are schools, nursing college, university, post office, police station, banks, housing areas, shops and factories.

Road accident statistics from 2006-2011 were used for analysis, which covers a total span of 6 years. Statistics from years before 2006 were used for reference and observation.

Variables used to produce the accident model were 85<sup>th</sup> percentile speed and flow rate. These two variables were chosen due to their significant effect upon road crashes at FT 050. Data collected for both variables was one-directional only, which was Ayer Hitam to Batu Pahat. Traffic volume data used in this research is from 2010.

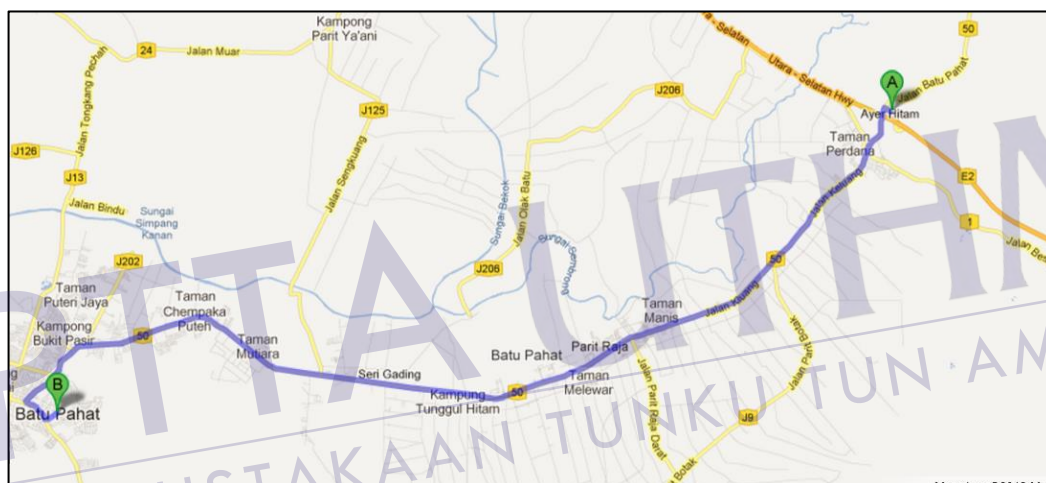

Figure 1.4: Map of FT 050 from KM 1 to KM 30 (Google Map, 2011)

#### 1.4 Structure of thesis

This thesis is structured and organised as follow:

a) Chapter 1 - Introduction

This chapter explains the background of the research, aim and objectives, scope of study, structure of the thesis.

b) Chapter 2 - Literature Review

The literature review is a critically written and comprehensive account of the related published works on the topic. It provides information on theories, models, and techniques used in this research.

c) Chapter 3 - Research Methodology

The research methodology explains clearly and in detail about how this research was conducted, which includes gathering of information and data, as well as processing and analysis of data.

d) Chapter 4 - Results and Analysis

This chapter presents the results obtained from the research. The writer also discusses the findings by comparing them with previous studies as mentioned in Chapter 2.

e) Chapter 5 - Conclusion and Recommendations

In this chapter, the writer draws conclusion for the whole research based on the findings of the results and linking it with the aim and objectives of the research.



PTTA UTHM  
PERPUSTAKAAN TUNKU TUN AMINAH

## CHAPTER 2

### LITERATURE REVIEW

#### 2.1 Introduction

Road accidents could happen anytime, anywhere on road to anyone. A complete definition of a road traffic accident by Transport Research Laboratory (TRL) is “a rare, random, multi-factor event always preceded by a situation in which one or more road users have failed to cope with their environment, resulting in a collision on the public highway which should be recorded by the police.”

#### 2.2 Road accident factors

There is rarely an accident situation in which only one “thing” or person is truly the sole cause of the accident; hence accidents are multi-factor events, basically grouped into 3 categories of factors:

- a) Human factors;
- b) Road and environment factors; and
- c) Vehicle factors

A study conducted by Lum & Reagen in 1995 confirmed one of the earliest comprehensive study (Treat, *et al.*, 1979) related to road accident factors that human

error was the factor that contributed the most to road accidents. This is followed by road environment factors and lastly vehicle factors. From Figure 2.1, it could be seen that some road accidents are not caused by a single factor alone, but due to a combination of multiple factors. This shows that one factor may interact with other factors in causing road accidents.

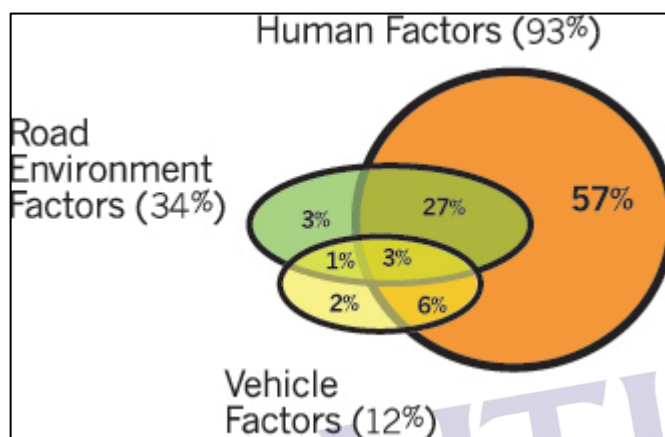

Figure 2.1: Road accident factors (Lum, H., & Reagen, J. A., 1995).

### 2.2.1 Human factors

In the Highway Safety Improvement Program Manual by the Federal Highway Administration (FHWA), a host of behavioural factors that contribute to road accidents have been identified. Some are attributes of drivers themselves, whilst others are related to the behaviour of drivers. Attributes such as advancing age and gender are unavoidable, whilst driver intoxication is a behavioural choice.

Some of the human factors that contribute to road accidents include:

- a) Age – older and younger drivers typically fall into higher accident risk groups.
- b) Gender – men are more likely than women to be involved in fatal accidents, are involved in a significant number of injury accidents.
- c) Aggressive driving – behaviours such as driving too fast for conditions, following too closely, inappropriate weaving in and out of traffic, and passing under unsafe conditions.
- d) Impaired driving – behaviours such as driving under the influence of drugs or being intoxicated.

- e) Occupant protection – drivers and passengers who choose not to put on safety restraints such as seat belt, helmet are at higher risk of serious injuries and death.
- f) Driver Inattention – distracted drivers who do not give sufficient attention whilst driving such as talking or texting on the mobile phone, eating or drinking and reading maps causes accidents.

### 2.2.2 Road and environment factors

Road and environment faults are causes beyond the control of the driver. Geometrically faulty roads and if not mended in the shortest time may cause more accidents on the road thus making the road not safe to be used.

Common road conditions that lead to road accidents are:

- a) Road surface damages – cracks, shoving, potholes, polishing, patching and rutting.
- b) Faulty sign boards, traffic lights and markings – cause drivers to lose a sense of direction and may cause accidents to happen.
- c) Failure of hillside and road structure - hillside failure is always linked to slope failure caused by the ground movement.
- d) Road geometry design failure – roads that are designed not according to geometric standard.

Environment factors literally have nothing to do with the roads. They are basically affected by the weather such as rain, wind and fog. The weather actually affects the road surface during rain and the visibility if it is foggy. The wind affects the vehicle directly especially where there is cross wind. The lighting condition on the road affects the visibility of the road greatly. When it is dark and without lamps on the road, it is very dangerous for the drivers as they may not be able to see very clearly what they are approaching.

### 2.2.3 Vehicle factors

Vehicle defects can be categorised as one of human errors because it is the responsibility of the driver to make sure that the vehicle is in safe condition before driving it. Some of the common defects which lead to road accidents are faulty brakes, signal lights, third brake light, front lights, back lights, rear mirror and side mirrors. Though most of these parts are not major parts of the vehicles, they are very important to ensure safety for the driver, passengers and other road users. The driver must ensure that all these parts are functioning well to prevent accidents.

## 2.3 Road design standards and road categories in Malaysia

Roads in Malaysia are categorised into two types of areas: rural and urban. Urban areas are defined as areas that have a population of at least 1000 where buildings and houses are gathered and business activity is prevalent. Rural areas can be considered as areas other than urban areas.

Generally there is no difference in the principles for designing rural and urban roads. Roads in urban areas, however, are characterized by high pedestrian activities and frequent stopping of vehicles. Lower design speeds are adopted for urban roads. It is for these reasons that variations in some aspects of geometric design are incorporated for these two groups of roads.

The design standard is classified into seven groups (R6, R5, R4, R3, R2 and R1) for rural areas and into seven groups (U6, U5, U4, U3, U2 and U1) for urban areas. These are in descending order of hierarchy.

Each road has its function according to its role either in the national network, regional network, state network or city/town network. The most basic function of a road is transportation. This can be further divided into two sub-functions that are mobility and accessibility.

In rural areas, roads are divided into five categories, namely, expressway, highway, primary road, secondary road and minor road. In urban areas, roads are divided into four categories, namely, expressway, arterial, collector and local street.



a) Expressway

An expressway is a divided highway for through traffic with full control of access and always with grade separations at all intersections. In rural areas, they apply to the interstate highways for through traffic and make the basic framework of national road transportation for fast travelling. In urban areas, they form the basic framework of road transportation system in urbanised area for through traffic.

b) Highways

They constitute the interstate national network and complement the expressway network. They usually link up directly or indirectly the federal capitals, state capitals and points of entry/exit to the country.

c) Primary Roads

They constitute the major roads forming the basic network of the road transportation system within a state. They usually link up the state capitals and district capitals or other major towns.

d) Secondary Roads

They constitute the major roads forming the basic network of the road transportation system within a district or regional development areas. They usually link up the major towns within the district or regional development areas.

e) Minor Roads

They apply to all roads other than those described above in the rural areas. They form the basic road network within a land scheme or other inhabited areas in a rural area.

f) Arterials

Arterials convey traffic from residential areas to the vicinity of the central business district or from one part of a city to another which does not intend to penetrate the city centre. Arterials do not penetrate identifiable



neighbourhoods. Smooth traffic flow is essential since it carries large traffic volume.

g) Collectors

A collector road is a road with partial access control designed to serve on a collector or distributor of traffic between the arterial and the local road systems. Collectors are the major roads which penetrate and serve identifiable neighbourhoods, commercial areas and industrial areas.

h) Local Streets

The local street system is the basic road network within a neighbourhood and serves primarily to offer direct access to abutting land. They are links to the collector road and thus serve short trip lengths. Through traffic should be discouraged.

Roads which function to provide long distance travel, will require higher, design speeds whilst road which serve local traffic, where the effect of speed is less significant can have a lower design speed. The characteristics of each road types are found in Table 2.1

Table 2.1: Characteristics of road categories (REAM, 2002)

AREA	ROAD CATEGORIES	Trip Length			Design Volume			Speed			NETWORK
		Long	Med	Short	High	Med	Low	High	Med	Low	
RURAL	Expressway	█			█			█			National network
	Highway	█			█			█			National network
	Primary Road		█		█				█		State network
	Secondary Road			█		█				█	District network
	Minor Road						█			█	Supporting network
URBAN	Expressway	█			█			█			National network
	Arterial		█		█				█		Major links to Urban centres
	Collector			█		█				█	Major streets within urban centres
	Local Street						█			█	Minor streets/town network.

Speed is a primary factor in all modes of transportation. The speed of vehicles on a road depends upon general conditions such as the physical



characteristics of the highway, the weather, the presence of other vehicles and the legal speed limitations.

The speeds are selected to meet the class of the road and its hierarchy to fulfil its function. Thus roads which are planned to provide long distance travel will be designed with a higher speed whilst those which provide short distance travel can be given a lower design speed.

Design speed is the maximum safe speed that can be maintained over a specific section of the road when conditions are favourable that the design features of the road governs. Table 2.2 and Table 2.3 indicate the selection of design speeds according to rural and urban standards.

Table 2.2: Design speed for roads for rural roads (REAM, 2002)

Design Standard	Category of Road	Design Speed (km/h)		
		Terrain		
		Flat	Rolling	Mountainous
R6	Expressway	110	100	80
R5	Highway	100	90	70
	Primary Roads	100	90	70
R4	Primary Roads	90	80	60
	Secondary Roads	90	80	60
R3	Secondary Roads	80	60	50
R2	Minor Roads	60	50	40
R1		50	50	30

Table 2.3: Design speed for urban roads (REAM, 2002)

Design Standard	Category of Road	Design Speed (km/h)		
		Area Type		
		I	II	III
U6	Expressway	100	90	80
U5	Arterials	90	70	60
	Collectors	80	70	60

Table 2.3 (continued)

U4	Arterials	80	60	50
	Collectors	70	60	50
	Local Streets	70	60	50
U3	Collectors	60	50	40
	Local Streets	60	50	40
U2	Local Streets	50	40	30
U1	Local Streets	40	30	30

Note:

Type I - relatively free in road location with very little problems as regards land acquisition, affected buildings or other socially sensitive areas.

Type II - Intermediate between I and III.

Type III - Very restrictive in road location with problems as regards land acquisition, affected buildings and other sensitive areas.

## 2.4 Geometric design of roads

The geometry of a road influences its safety performance. While studies of contributing factors to road accidents show that human factors predominate, roadway factors are the second most common category, with vehicle factors last.

### 2.4.1 Sight distance

Sight distance is the length of road ahead visible to drivers. The ability of a driver to see ahead is of great importance to ensure a safe and efficient operation of a road. Sight distance includes stopping sight distance and passing sight distance. Sight distance applied to multilane divided roads is only the safe stopping sight distance.

### 2.4.1.1 Stopping sight distance

The stopping sight distance is the length required to enable a vehicle traveling at or near the design speed to stop before reaching an object in its path. Minimum stopping distances are as shown in Table 2.4.

Table 2.4: Minimum stopping sight distance (REAM, 2002)

Design speed (km/h)	Minimum stopping sight distance (m)
110	250
100	205
90	170
80	140
70	110
60	85
50	65
40	45
30	30

The safe stopping sight distances on upgrades are shorter and those on downgrades are longer. However the effect of grade to sight distance need not be considered as the sight distance available on downgrades is larger than on upgrades and this more or less provides for the necessary corrections for grade.

### 2.4.1.2 Passing sight distance

Most roads in rural areas are two-lane two way on which vehicles frequently overtake slower moving vehicles on a lane regularly used by the opposing traffic. Passing sight distance for use in design should be determined on the basis of the length needed to safely complete a normal passing manoeuvre. Table 2.5 gives the minimum passing sight distance to be used for each speed design.

Table 2.5: Minimum passing sight distance (REAM, 2002)

Design speed (km/h)	Minimum passing sight distance (m)
110	730
100	670
90	610
80	550
70	490
60	410
50	350
40	290
30	230

Specific adjustment for design use is not available. The effect of grade is not considered in design as the effect is compensated either in upgrade or downgrade.

#### 2.4.2 Horizontal alignment

In the design of horizontal curves, it is necessary to establish the proper, relation between the design speed and curvature and also their joint relations with superelevation and side friction.

##### 2.4.2.1 Simple curves

Figure 2.2 is a layout of a simple horizontal curve. The curve is a segment of a circle with radius,  $R$ . The minimum radius is a limiting value of curvature for a given speed and is determined from the maximum rate of superelevation and the maximum allowable side friction factor. The minimum safe radius can be calculated from the standard curve formula:

$$R = \frac{v^2}{127(e + f)} \quad (2.1)$$

$R$  = minimum radius of circular curve (m)

$v$  = design speed (km/h)

$e$  = maximum superelevation rate

$f$  = maximum allowable side friction

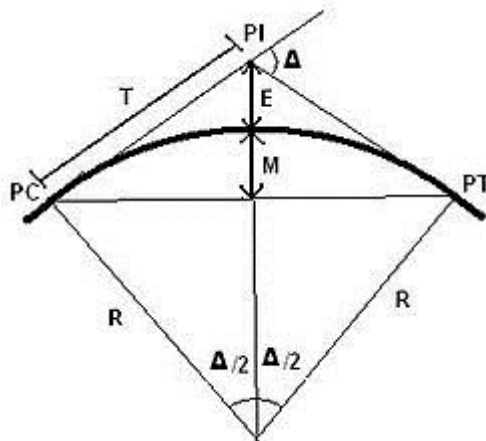

Figure 2.2: Layout of a simple horizontal curve (Garber & Hoel, 2009)

Table 2.6 lists the minimum radius to be used for the designated design speed and maximum superelevation rates.

Table 2.6: Minimum radius for simple curves design (REAM, 2002)

Design speed (km/h)	Minimum radius (m)	
	$e = 0.06$	$e = 0.10$
110	560	500
100	465	375
90	335	305
80	280	230
70	195	175
60	150	125
50	100	85
40	60	50
30	35	30

**2.4.2.2 Compound curves**

Compound curves consist of two or more simple curves in succession, turning in the same direction, with any two successive curves having a common tangent point. Figure 2.3 shows a typical layout of a compound curve, consisting of two simple curves. To avoid abrupt changes in the alignment, the radii of any two consecutive simple curves should not be widely different.

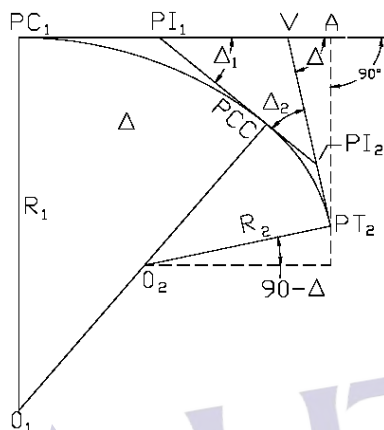

Figure 2.3: Layout of a compound curve (Garber & Hoel, 2009)

**2.4.2.3 Reverse curves**

Reverse curves usually consists of two simple curves with equal radii turning in opposite directions with a common tangent. They are usually used to change the alignment of a highway. Figure 2.4 illustrates a reverse curve with parallel tangents.

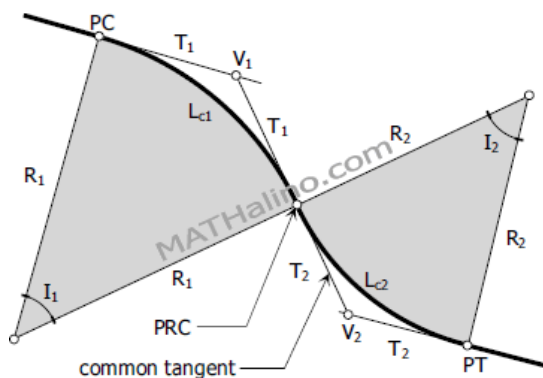

Figure 2.4: Layout of a reverse curve with parallel tangents (www.mathalino.com)

### 2.4.2.4 Spiral curves

Spiral curves are placed between tangents and circular curves or between two adjacent circular curves having substantially different radii. Spiral curves provide a vehicle path that gradually increases or decreases the radial force as the vehicle enters or leaves a circular curve. Figure 2.5 shows the layout of a spiral curve.

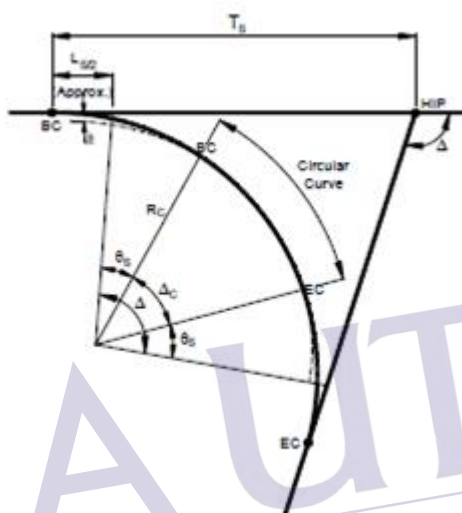

Figure 2.5: Layout of a spiral curve (www.expertsmind.com)

### 2.4.3 Vertical alignment

The vertical alignment of a highway consists of straight sections known as grades connected by vertical curves. The topography of the area through which the road traverses has a significant impact on the design of the vertical alignment. Vertical curves are used to provide a gradual change from one tangent grade to another so that vehicles can run smoothly as they traverse the highway. These curves are usually in parabolic shape. The curves are classified as crest of sag, as illustrated in Figure 2.6.

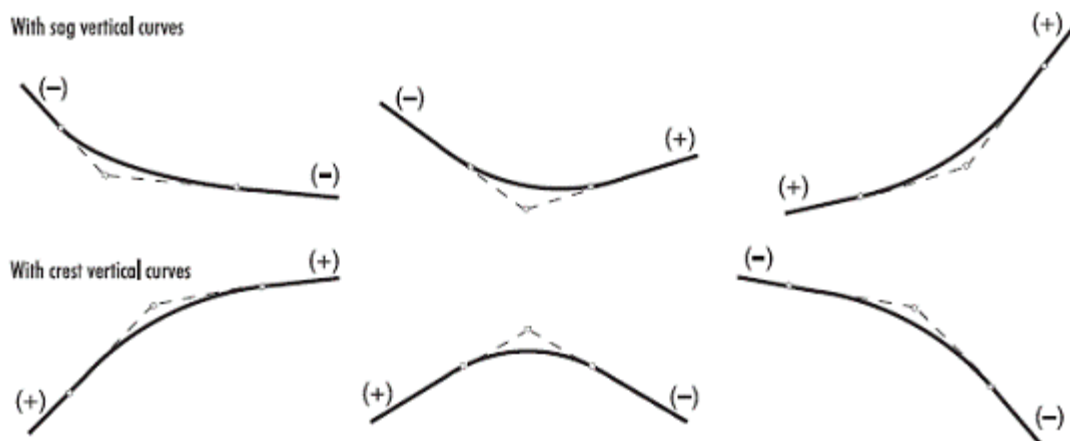

Figure 2.6: Types of vertical curves (www.ec.europa.eu)

The vertical profile of road affects the performance of vehicles. The maximum grade controls in terms of design speed is summarised in Table 2.7a-f.

Table 2.7a: Maximum grades for R1, R2, U1 and U2 standard roads (REAM, 2002)

Type of Terrain / Area	Design speed (km/h)					
	30	40	50	60	70	80
Flat & Type I	8	7	7	7	7	6
Rolling & Type II	11	11	10	10	9	8
Mountainous & Type III	16	15	14	13	12	10

Table 2.7b: Maximum grades for R3 and R4 standard roads (REAM, 2002)

Type of Terrain / Area	Design speed (km/h)					
	50	60	70	80	90	100
Flat	7	7	7	6	6	5
Rolling	9	8	8	7	7	6
Mountainous	10	10	10	9	9	8

Table 2.7c: Maximum grades for U3 and U4 standard roads (REAM, 2002)

Type of Terrain / Area	Design speed (km/h)				
	40	50	60	70	80
Type I	9	9	9	8	7
Type II	12	11	10	9	8
Type III	13	12	12	11	10



Table 2.7d: Maximum grades for R5 standard roads (REAM, 2002)

Type of Terrain / Area	Design speed (km/h)					
	60	70	80	90	100	110
Flat	5	5	4	4	3	3
Rolling	6	6	5	5	4	4
Mountainous	8	7	7	6	6	5

Table 2.7e: Maximum grades for U5 standard roads (REAM, 2002)

Type of Terrain / Area	Design speed (km/h)					
	50	60	70	80	90	110
Type I	8	7	6	6	5	5
Type II	9	8	7	7	6	6
Type III	11	10	9	9	8	8

Table 2.7f: Maximum grades for R1, R2, U1 and U2 standard roads (REAM, 2002)

Type of Terrain / Area	Design speed (km/h)			
	80	90	100	110
Flat & Type I	4	4	3	3
Rolling & Type II	5	5	4	4
Mountainous & Type III	6	6	6	5

According to REAM, the desirable maximum should be aimed at in most cases. The total upgrade for any section of road should not exceed 3000m, unless the grade is less than 4%.

Minimum lengths of vertical curves are determined by the sight distance requirements. The stopping sight distance is the major control for the safe operation at the design speed chosen. The basic formulas for length of a parabolic vertical curve in terms of algebraic difference in grade and sight distance are as follows:

$$L = \frac{AS^2}{404} \quad (\text{for } S < L) \quad (2.2)$$

and

$$L = 2S - \frac{404}{A} \quad (\text{for } S > L) \quad (2.3)$$

where:

$L$  = minimum length of vertical curve (m)

$S$  = sight distance (m)

$A$  = algebraic difference in grades (%)

Table 2.8 indicates the minimum  $k$  values that are to be used in design for the various design speeds.  $k$  is the calculated value of  $L/A$  used in determining the horizontal distance from the beginning of the vertical curve to the apex or low point of the curve.

Table 2.8: Minimum  $k$  values for vertical curve design (adapted from Guidelines on Geometric Design of Roads, REAM)

Design speed (km/h)	Minimum $k$ value (for crest vertical curve)	Minimum $k$ value (for sag vertical curve)
110	151	62
100	105	51
90	71	40
80	49	32
70	31	25
60	15	18
50	10	12
40	10	8
30	5	4

## 2.5 Overview of road accidents in Malaysia

Over the last two decades, Malaysia has experienced a remarkable period of economic expansion and growth in population, economy, industrialisation and motorisation. The population increased to 29.2 million (Jul 2012 est.) at a growth rate of about 1.54 % (2012 est.). The total registered vehicles in Malaysia increased from 10,589,804 in 2000 to 20,188,565 vehicles in 2010.

The increase in population and motorisation led to a consequent increase in the number of road traffic accidents. Referring to Figure 2.7 obtained from the Ministry of Transport Malaysia (MOT), the total number of accidents rose from 265,175 cases in 2001, and grew to 414,421 cases in 2010.

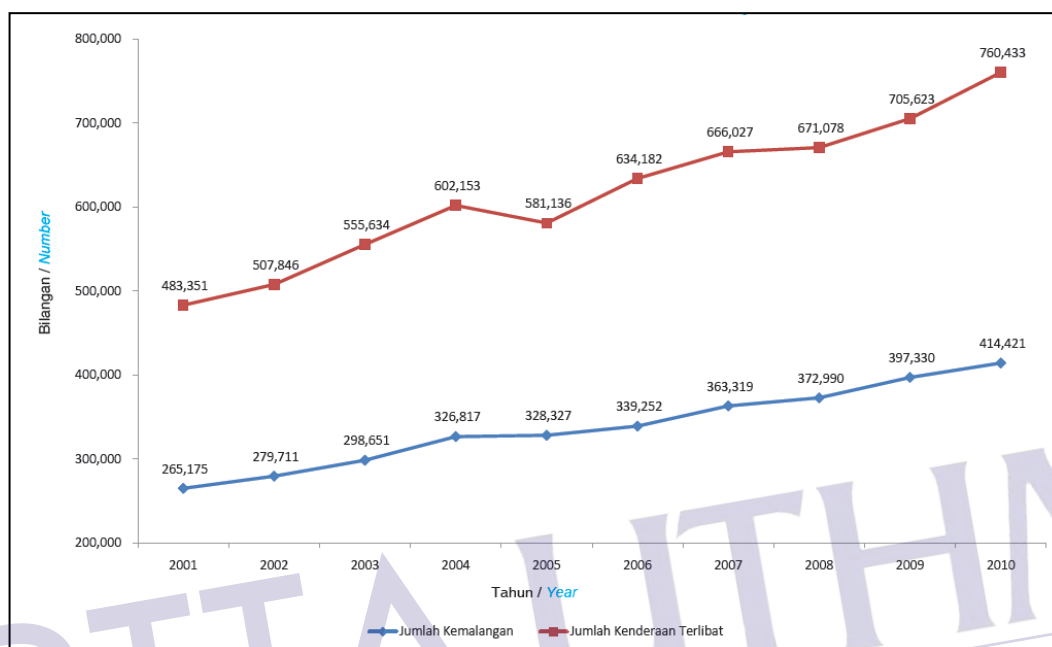

Figure 2.7: Total road accidents and motor vehicles involved, 2001-2010 (MOT, 2010)

The number of fatalities (death within 30 days after an accident) however, increased at a much slower rate from 5,849 in 2001 to 6,872 in 2010. Based on the report released by International Traffic Safety Data and Analysis Group (IRTAD) in 2012, the fatality index due to road accidents in Malaysia is 23.8 per 100 000 population in 2010, which is still a very high rate in comparison to Australia (6.1), Japan (4.5) and South Korea (11.3).

Figure 2.8 shows that though the total of road accidents increases, the number of casualties shows a dropping trend since 2005. Those who experienced serious injuries dropped from 9,397 in 2005 to 7,781 in 2010 whilst minor injured casualties dropped from 31,429 in 2005 to 13,616 in 2010. In terms of percentage, seriously injured casualties dropped 17% whilst minor injured casualties dropped 57%.

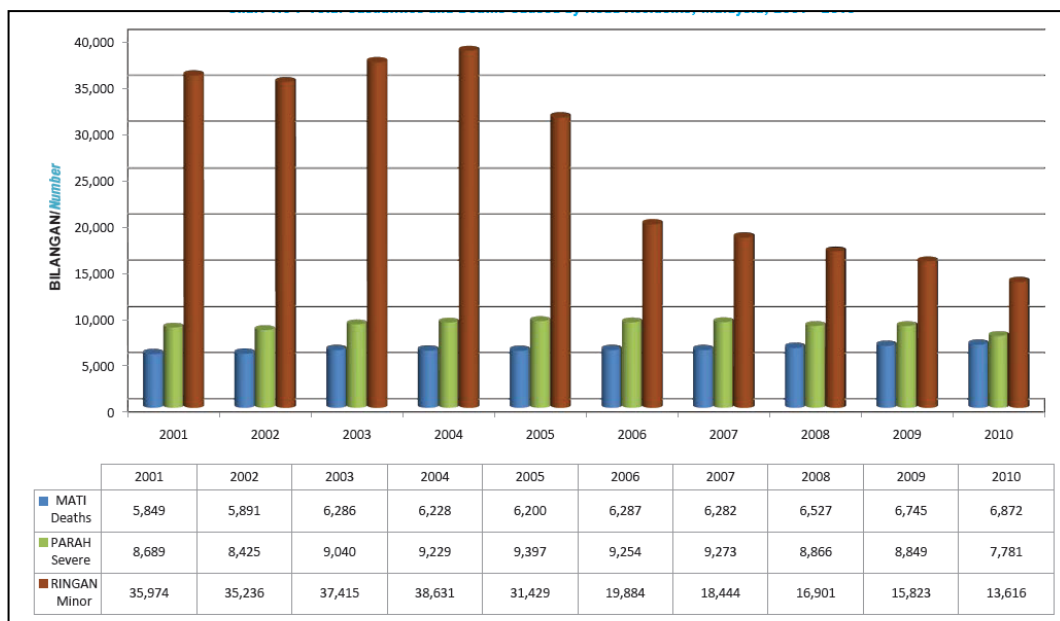

Figure 2.8: Total casualties and deaths caused by road accidents, 2001-2010 (MOT, 2010)

## 2.6 Influence of speed on road accidents

The spot speed of a vehicle is the speed of an individual vehicle measured as that vehicle passes a particular point on the road, measured usually in kilometre per hour (km/h). It is most commonly used in research into road accidents. This speed measurement yields a distribution of speed for vehicles using a particular section of road.

Speed distribution can be captured by means of a number of statistical parameters describing the characteristics of the distribution. Amongst the common parameters are average or mean speed, 85<sup>th</sup> percentile speed, standard deviation and coefficient of variation. 85th percentile is the speed at or below which 85 per cent of drivers drive. Standard deviation characterise the spread or variability of speeds on any road. Coefficient of variation is the ratio of the standard deviation to the mean; a dimensionless number describing the shape of the distribution.

Over the last 50 years, extensive research on the effect of speed on accidents had been conducted, one of the earliest being *Accidents on main rural highways related to speed, driver and vehicle* by Solomon D in 1964. Major national reviews

## REFERENCES

- Andersson G and Nilsson G (1997). *Speed management in Sweden*. Swedish National Road and Transport Institute VTI, Linköping.
- Aronsson, K., & Bang, K. L. (2006). Influence on Vehicle Speed Profiles of Interactions with other Road Users. *European Transport Conference*. Strasbourg: Association for European Transport.
- Baruya A (1998). *Speed-Accident Relationships on Different Kinds of European Roads*. Deliverable D7 MASTER-project. Transport Research Laboratory, Crowthorne.
- Bowie NN, and Waltz M (1994). *Data Analysis of the Speed-Related Crash Issue*. In: Auto and Traffic Safety. Vol. 2, Winter 1994.
- Fildes BN, Rumbold G and Leening A (1991). *Speed Behaviour and Drivers' Attitude to Speeding*. Report No. 16. Monash University Accident Research Centre, Victoria Australia, June 1991.
- Department of Statistics, Malaysia. (2010). *Population Distribution and Demographic Characteristics*. Putrajaya: Department of Statistics, Malaysia.
- Department for Transport (2001). *Road safety engineering good practice guide*. London. First edition.
- Elvik R (1999). *Area-wide urban traffic calming schemes: a meta -analysis of safety effects*. In: Proceedings of the conference "Traffic safety on two continents". Malmo Sweden, September 20-22. VTI-Konferens No. 13A, Part 6. VTI. Linköping.
- European Transport Safety Council (1995). *Reducing Traffic Injuries Resulting From Excess and Inappropriate Speed*. ETSC, Brussels, 1995.
- European Transport Safety Council (ETSC) (1996). *Low cost road and traffic engineering measures for casualty reduction*. European Transport Safety



Council, Brussels.

Federal Highway Administration. (2003). *Benefits of Access Management*. New Jersey: Federal Highway Administration.

Fildes, B. N., Rumbold, G., & Leening, A. (1991). *Speed Behaviour and Drivers' Attitude to Speeding*. Victoria, Australia: Monash University Accident Research Centre.

Fildes B N & Lee S J (1993). *The speed review: Road environment, behaviour, speed limits, enforcement and crashes*. Monash University, Accident Research Centre for Federal Office of Road Safety. CR 127 (FORS); CR 3/93 (RSB), Clayton, Victoria,

Finch, D. J., Kompfner, P., Lockwood, C. R., & Maycock, G. (1994). *Speed, speed limits and accidents*. Crowthorne: Transport Research Laboratory.

Garber, N.J., Ehrhart, A.A., (2000). Effects of speed, flow, and geometric characteristics on crash frequency for two-lane highways. *Transport. Res. Rec.* 1717, 76–83.

Garber, N.J. & Hoel, L.A., (2009). *Traffic & Highway Engineering*. 4<sup>th</sup> ed. Toronto: Cengage Learning.

Gårder, P. E. (2004). The impact of speed and other variables on pedestrian safety in Maine. *Accident Analysis & Prevention*, 36 (4), 533-542.

Golob, T. F., Recker, W. W., & Alvarez, V. M. (2004). Freeway safety as a function of traffic flow. *Accident Analysis & Prevention*, 36 (6), 933-946.

Gorrill, D. (2007). *Transverse Rumble Strips*. Minnesota: Minnesota Department of Transportation.

Greibe, P. (2003). Accident prediction models for urban roads. *Accident Analysis and Prevention*, 35 (2), 273-285.

Herbel. S., Laing, L., McGovern, C. (2010). *Highway Safety Improvement Program (HSIP) Manual*. FHWA-SA-09-029. Federal Highway Administration, McLean, VA.

Highway Planning Unit. (2011, June). *Road Traffic Volume Malaysia 2010*.

Retrieved April 20, 2012, from JKR website

<http://rakan1.jkr.gov.my/ckjg/index.php?r=download/getfile&id=150&file=%2Fckjg%2Fvar%2Fdownload%2FRRTVM2010.pdf>

- Hiselius, L. W. (2004). Estimating the relationship between accident frequency and homogeneous and inhomogeneous traffic flows. *Accident Analysis & Prevention*, 36 (6), 985-992.
- Hong, D., Kim, J., Kim, W., Lee, Y., & Yang, H. C. (2005). Development of traffic accident prediction models by traffic and road characteristics in urban areas. *5th Eastern Asia Society for Transportation Studies Conference* (pp. 2046-2061). Fukuoka: Association for Planning Transportation Studies.
- Hawkins, D. M. (1980), Identification of Outliers, Chapman and Hall.
- Iglewicz, B. and Hoaglin, D. (1993), "Volume 16: How to Detect and Handle Outliers", The ASQC Basic References in Quality Control: Statistical Techniques, Edward F. Mykytka, Ph.D., Editor.
- Institut Kerja Raya Malaysia & Transport Research Laboratory (1995). *Interim Guide on Identifying, Prioritising and Treating Hazardous Locations on Roads in Malaysia*. Kuala Lumpur: Jabatan Kerja Raya Malaysia.
- International Traffic Safety Data and Analysis Group (2012). *Road Safety Annual Report 2011*. France: International Transport Forum
- Jabatan Kerja Raya (1986). *A Guide On Geometric Design of Roads*. Kuala Lumpur: Arahan Teknik (Jalan) 8/86
- Jokschi, H. C. (1993). Velocity change and fatality risk in a crash – a rule of thumb. *Accident Analysis and Prevention*, 25 (1), 103-104.
- Kloeden C N, McLean A J and Glonek G (2002). *Reanalysis of travelling speed and the risk of crash involvement in Adelaide South Australia*. Australian Transport Safety Bureau ATSB. Report No. CR207.
- Kloeden, C. N., McLean, A. J., Moore, V. M., & Ponte, G. (1997). Travelling Speed and the Risk of Crash Involvement. Canberra: Federal Office of Road Safety.
- Kloeden C N, Ponte G and McLean A J (2001). *Travelling speed and the risk of crash involvement on rural roads*. Australian Transport Safety Bureau ATSB. Report No. CR 204.
- Liu, P., Huang, J., Wang, W., & Xu, C. (2011). Effects of transverse rumble strips on safety of pedestrian crosswalks on rural roads in China. *Accident Analysis & Prevention*, 43 (6), 1947-1954.
- Lum, H., & Reagen, J. A. (1995, Winter). Interactive Highway Safety Design Model: Accident Predictive Module. *Public Roads*, 59(2).



PTFA UTHM  
 REPPUSIAKKAAN TEKNIKAL TUN AMINAH

- Lynam, D. & Hummel, T. (2002). The effect of speed on road deaths and injuries. Crowthorne, Berkshire: Transport Research Laboratory Limited. (Unpublished).
- Martin, J.-L. (2002). Relationship between crash rate and hourly traffic flow on interurban motorways. *Accident Analysis & Prevention*, 34 (5), 619-629.
- Ministry of Transport Malaysia. (2010). *Transport Statistics Malaysia 2010*. Retrieved April 20, 2012, from MoT website  
<http://www.mot.gov.my/Publication/Official/Statistik%20Pengangkutan%20Malaysia%202010-comp.pdf>
- Mustakim, F. (2005). *Treating Hazardous Locations at Federal Route 50*. Universiti Teknologi Malaysia: Master's Project Report.
- Mustakim, F., & Fujita, M. (2011). Development of Accident Predictive Model for Rural Roadway. *World Academy of Science, Engineering and Technology* (58), 126-131.
- Mustakim, F., et al. (2008). Blackspot Study and Accident Prediction Model Using Multiple Linear Regression. *First International Conference on Construction In Developing Countries (ICCIDC-I)*. Karachi.
- Pang, T. Y., Radin Umar, R. S., Azhar, A. A., Megat Ahmad, M. H., & Nasir, M. T. (2000). Accident Characteristics of Injured Motorcyclists in Malaysia. *Medical Journal Malaysia*, 55 (1), 45-50.
- Persaud, B., Dzbik, L., 1992. Accident prediction models for freeways. *Transport. Res. Rec.* 1401, 55–60.
- Quimby, A., Maycock, G., Palmer, C., & Buttress, S. (1999). The factors that influence a driver's choice of speed — a questionnaire study. Crowthorne, Berkshire: Transport Research Laboratory Limited.
- Ramli, Z. (2011). *Development of Accident Prediction Model by Using Artificial Neural Network (ANN)*. Universiti Tun Hussein Onn Malaysia.
- The Road Engineering Association of Malaysia (2002). *Guidelines on Geometric Design of Roads*. Shah Alam: GI 2/2002
- Sarani, R., Roslan, A., & Saniran, N. (2011). *Motorcycle*. Malaysian Institute of Road Safety Research (MIROS), Accident Database System and Analysis (ASDA) Unit . Kuala Lumpur: MIROS.
- Solomon, D. R. (1964). *Accidents on Main Rural highways related to Speed, Driver and Vehicle*. US Department of Commerce, Federal Bureau of Highways,





Washington DC.

Stuster J , Coffman Z and Warren D (1998). *Synthesis of Safety Research Related to Speed and Speed Management*. Publication no. FHWA-RD-98-154. Federal Highway Administration. McLean, VA..

Sullivan, E.C., 1990. Estimating accident benefits of reduced freeway congestion. J. Transport. Eng. 116, 167–180.

Taylor M C (2001). *The speeds of vehicles which are involved in fatal accidents*. In: Traffic Engineering & Control, February 2001.

Taylor, M. C., A. Baruya and J. V. Kennedy (2002). *The relationship between speed and accidents on rural single-carriageway roads*. TRL report TRL511. Transport Research Laboratory, Crowthorne, Berkshire.

Taylor, M. C., D. Lynam and A. Baruya (2000). *The effects of drivers' speed on the frequency of road crashes*. TRL Report 421. Transport Research Laboratory, Crowthorne, Berkshire.

Taylor, M. C., & Wheeler, A. (2000). Accident reductions resulting from village traffic calming schemes. *European Transport Conference*. pp. 163-174. Cambridge: Homerton College.

Transportation Research Board (2000). *Highway Capacity Manual*. Washington, D.C.: HCM 2000

Treat, J. R., Tumbas, N. S., McDonald, S. T., Shinar, D., Hume, R. D., Mayer, R. E., et al. (1979). *Tri-level Study of the Causes of Traffic Accidents*. Washington, D.C.: U.S. Department of Transportation.

Wan Manan, W. N. (2011). *A Prediction Model at Un-signalized Intersections Using Multiple Regression Method*. Universiti Tun Hussein Onn Malaysia: Master's Project Report.

Wheeler, A. and M. Taylor (2000). *Changes in accident frequency following the introduction of traffic calming in villages*. TRL report 452. Transport Research Laboratory, Crowthorne, Berkshire

Zabli, Z. A. (2006). *Analisis Pembangunan Pangkalan Data Kemalangan Jalanraya Menggunakan GIS*. Universiti Tun Hussein Onn Malaysia: Bachelor Degree's Project Report.

Zolkepli, F. (2009, May 05). Deadliest stretch in Johor claims 36 lives every year. *The Star*. Retrieved June 17, 2009, from <http://thestar.com.my>



PTT UTHM  
PEPUSIAKAN TUNKU TUN MINAH