

RFID-BASED INDOOR POSITIONING OF AUTONOMOUS AID FOR DISABLE
PEOPLE

INTAN SURIA BINTI ZAKARIA

A project report submitted in partial fulfillment of the
requirement for the award of the degree
Master of Electrical Engineering



Faculty of Electrical and Electronic Engineering
University Tun Hussein Onn Malaysia

JANUARY 2013

DEDICATION

Special dedicated to my mother Rahmah Idar, my father Zakaria Ibrahim, my husband Sahreen Solimin, my son Qaiser Zafran and all my family's member thank you so much for the support and attention to me.



PTTA UTHM
PERPUSTAKAAN TUNKU TUN AMINAH

ACKNOWLEDGEMENT

First of all, Alhamdulillah, praise to Allah for His Blessings I have finished writing this dissertation for Master of Electrical Engineering. I express my sincere appreciation to my supervisor, Dr Babul Salam KSM Kader Ibrahim and my co supervisors, Dr Rosli Omar and Dr Muhammad Mahadi Abdul Jamil for their encouragement, guidance, advices and critics. Without their continuous support and interest, this research could not be finished.

My appreciation also goes to my family especially my husband and my parents for their biggest support and involvement in every aspect. Last but not least, my appreciation goes to my fellow friends and everyone involved directly or indirectly in order to finish this study and compilation of this dissertation.



PTTA UTHM
PERPUSTAKAAN TEKNIK DAN TEKNOLOGI AMINAH

ABSTRACT

Nowadays, global positioning system (GPS) is widely used in localization area because it's very capable and reliable. However, in indoor positioning, GPS capabilities are very limited since the satellite signals are typically strongly attenuated by walls and ceiling. Thus, this project introduced the concept which presents a self-localization of a mobile robot by fusing radio frequency identification (RFID) system and wireless communication using XBee module to be used in indoor environment. Two Xbee devices will be used to transfer data from the remote control unit to mobile robot. Aims of this project are to create a mobile robot that reacts to the remote control to go to the desired position as command. To meet the desired aim of this project, practical and compact design technique are emphasized in order to create a mobile robot and the remote control. Sixteen RFID cards are arranged in a fixed pattern on the floor. A unique code of each RFID card provides the position data to the mobile robot. An RFID reader act as antenna will be installed to read the card data on the below of the mobile robot. The user can make it come by easily pressing the remote control by informing the user location.

Keywords: RFID, RFID reader, RFID tag, indoor location identification, mobile robot, remote control, navigation, wireless communication.

ABSTRAK

Kini, sistem kedudukan global (GPS) digunakan secara meluas di kawasan penyetempatan kerana ia sangat berkebolehan dan boleh dipercayai ketepatannya. Walau bagaimanapun, dalam kedudukan tertutup, keupayaan GPS adalah sangat terhad kerana isyarat satelit biasanya lemah disebabkan oleh dinding dan siling. Oleh itu, projek ini memperkenalkan konsep penyetempatan robot mudah alih dengan menggabungkan sistem pengenalan frekuensi radio (RFID) dan komunikasi tanpa wayar menggunakan modul XBee untuk digunakan dalam persekitaran dalaman. Dua peranti Xbee akan digunakan untuk memindahkan data dari unit kawalan jauh kepada robot mudah alih. Matlamat projek ini adalah untuk mencipta sebuah robot mudah alih yang akan bertindak balas kepada alat kawalan jauh untuk pergi ke kedudukan yang dikehendaki seperti arahan. Untuk memenuhi matlamat projek yang diinginkan, teknik reka bentuk yang praktikal dan padat ditekankan dalam usaha untuk mencipta sebuah robot mudah alih dan alat kawalan jauh. Enam belas kad RFID disusun dalam corak yang tetap di atas lantai. Kod unik setiap kad RFID menyediakan data kedudukan kepada robot mudah alih. Pembaca RFID bertindak sebagai antena akan dipasang untuk membaca data kad di bawah robot mudah alih. Pengguna boleh membuat robot mudah alih datang dengan mudah iaitu menekan alat kawalan jauh dengan memaklumkan lokasi pengguna.

CONTENTS

TITLE	i
DECLARATION	iii
DEDICATION	iv
ACKNOWLEDGEMENT	v
ABSTRACT	vi
ABSTRAK	vii
TABLE OF CONTENTS	viii
LIST OF FIGURES	x
LIST OF TABLES	xii
CHAPTER 1 INTRODUCTION	
1.1 Overview	1
1.2 Problem Statement	2
1.2.1 GPS Cannot Be Used In Indoor Positioning	2
1.2.2 Wheelchair and User Matters Problem	3
1.3 Objectives	3
1.4 Scope	4
1.5 Approach to the Study	4
1.6 Significant of the study	5
1.7 List of Publications	5
CHAPTER 2 LITERATURE REVIEW	
2.1 Related Work	6
2.2 Research Comparison	12
CHAPTER 3 METHODOLOGY	
3.1 System Architecture	14
3.2 Hardware Design	16
3.2.1 Types of Microcontroller	17

3.2.2	4x4 Keypad	17
3.2.3	Xbee OEM RF Module	19
3.2.4	RFID System	21
3.2.5	Graphic LCD 84x48	23
3.3	Circuits Schematic	23
3.4	Software Design	26
3.4.1	Low-level Software	27
3.4.2	High-level Software (Application)	29
3.5	Motor Speed Division	31

CHAPTER 4 RESULT AND DISCUSSION

4.1	Hardware Development	35
4.1.1	Mechanical	35
4.1.2	Electronics	36
4.1.3	Specification	39
4.2	Software Development	39
4.2.1	Low-level Software	39
4.2.2	High-level Software	42

CHAPTER 5 CONCLUSION

5.1	Conclusion	48
5.2	Recommendations	49
5.2.1	Encoder	49
5.2.2	Four Wheels	49
5.2.3	Obstacle Avoidance	50
5.2.4	Section	50
5.2.5	Improvement in mobile robot circuit	50

REFERENCES	51
-------------------	-----------

VITA	53
-------------	-----------

APPENDIX A: Mobile robot coding	54
--	-----------

APPENDIX B: Remote control coding	68
--	-----------

APPENDIX C: UART coding	72
--------------------------------	-----------

APPENDIX D: Motor coding	76
---------------------------------	-----------

LIST OF FIGURES

2.1	Localization system based on tag-floor for an indoor mobile robot	7
2.2	High-level system configuration with two RFID tags	8
2.3	Scanning range of the RFID antenna	9
2.4	Position tracing system	10
2.5	Driving circuit for the mobile robot	11
3.1	Flowchart of project activities	14
3.2	Device configuration	15
3.3	System architecture	15
3.4	4x4 keypad	18
3.5	Internal structure of the 4X4 keypad	18
3.6	Interface PIC with keypad	19
3.7	Xbee wireless module	20
3.8	RFID reader	21
3.9	RFID tag	22
3.10	RFID tag distribution pattern	22
3.11	Mobile robot board schematic design	24
3.12	Keypad board schematic design	26
3.13	Subroutine flowchart for 4x4 keypad	27
3.14	Subroutine flowchart for motor control	28
3.15	Manual mode flowchart	29
3.16	High-level software application	30
3.17	Configuration of the robot movement	31
3.18	Configuration for robot moving forward	32
3.19	Configuration for robot moving backward	32
3.20	Configuration for robot moving left	33
3.21	Configuration for robot moving right	34

4.1	Main body of the robot	36
4.2	Mobile robot circuit	37
4.3	Keypad circuit	38
4.4	X-CTU configuration	40
4.5	HyperTerminal configuration	41
4.6	Tag's ID in ASCII	41
4.7	The RFID card	42
4.8	Indoor positioning test 1	42
4.9	Indoor positioning test 2	43
4.10	Indoor positioning test 3	44
4.11	Indoor positioning test 4	44
4.12	Indoor positioning test 5	45
4.13	Indoor positioning test 6	46
4.14	Indoor positioning test 7	46
4.15	Indoor positioning test 8	47



LIST OF TABLES

2.1	Comparison between each research	12
3.1	List of component	16
3.2	Pin signals of Xbee wireless module	20
3.3	Pin signals of LCD Nokia 3310	23
4.1	List of component for mobile robot circuit	37
4.2	List of component for keypad circuit	38
4.3	Specification outcome of the mobile robot	39



PTTA UTHM
PERPUSTAKAAN TUNKU TUN AMINAH

CHAPTER 1

INTRODUCTION

This chapter will focus on the brief introduction of the project to be carried out. The important overview or description including the problem statement, project objectives, and project scopes are well emphasized in this part.

1.1 Overview

Nowadays, many activities are required reliably the location of a person and an object. It is whether in the form of physical coordinates or as a symbolic label[1]. In mobile robotics areas, localization is the main and complex problem. The localization capability becomes important for path-planning, motion control and positioning in any given environment[2].

Therefore, localization system in indoor environment becomes a hot research topic in the technology of location-aware[3]. This technology is very useful for the paraplegia patients especially as it can grant them freedom of movement[4].

There are two methods of localization which is relative localization and absolute localization[5]. Example of relative localization is dead-reckoning and inertial navigation. Dead-reckoning sensors such as encoders can estimate the displacement to the starting position and orientation[2, 6]. However, dead-reckoning has no external reference signal so it can't estimate error accumulate over time. In order to improve the accuracy of localization, many approaches combine external sensors such as cameras, beacon, laser range finder, sonar or global positioning

system (GPS)[5]. For absolute localization, it uses a camera, GPS, ultrasonic or infrared sensors recognize the absolute location from reference point[2, 7].

Thus, an RFID technology has been applied for this project. Actually, an RFID is functioning as object recognition and recently it is applied to robotic for the localization system especially in indoor environment regarding to the features which can be used practically[2]. An RFID tag can provide location information of a robot within the classification of information by its unique code[5]. With these features, it's suitable for solving the problem of conventional sensor system and implement a new forming robot system for localization[2].

RFID tags are arranged in a fixed pattern on the floor. A unique code of each RFID tag provides the position data to the mobile robot. An RFID reader act as an antenna will be installed to read the tag data on the below of the mobile robot. The user can make it come by easily pressing the remote control by informing the user location. Then the user location data will emit by wireless.

There are several of wireless techniques that can be located in an indoor environment, but in this project, ZigBee technology is chosen. That is because of the advantages of this technology which is low-cost, small size, little energy and so on[8]. It's suitable to use in short range data transmission between electronic components.

1.2 Problem statement

1.2.1 GPS cannot be used for indoor positioning

Global Positioning System (GPS) is a capable and reliable localization system for outdoor environments[9]. However, in an indoor environment its capabilities are very limited since the satellite signals are typically strongly attenuated by walls and ceiling[10]. In addition, in indoor environments localization system it required to differentiate locations inside the room and therefore, the domain-meter accuracy is expected. Thus, RFID-based techniques were used to solve this matter.

1.2.2 Wheelchair and user matters problem

Wheelchair is widely used by patients with gait disorder because it is inexpensive and enables to move easily as long as a little muscle power is left in upper limbs[11]. However, wheelchairs have other problems with its hardware and user matters[12]. One of the problems of the traditional wheelchair, the user still needs their family member to bring his wheelchair before the user can use it[13]. Another type of transportation device that can solve this problem mentioned above should be developed for a better welfare society. If these problems could be solved, it can help the user to move freely without seeking the help of their family members. In addition, it can reduce the burden on users when handling a wheelchair.

1.3 Aim and objectives of the project

The aim of this project is to develop a self-localization in the indoor environment of a mobile robot as a prototype of mobility aid for disabled people using RFID technology with wireless network. In order to achieve this aim, the objectives are formulated as follows:-

- i. To design a remote control for a mobile robot using microcontroller and wireless systems.
- ii. To develop a remote control that could give commands to mobile robot to a desired location of RFID tag.
- iii. To design a mobile robot that is capable of finding a desired location using RFID technology.
- iv. To design dual mode of positioning which is manual mode and automatic mode.
- v. To explore the functionality and system architecture of RFID.

1.4 Scope

The works undertaken in this project are limited to the following aspect:

- i. Mobile robot will be controlled wirelessly by keypad 4x4.
- ii. The wireless system module is XBee S1 1mW Wire Antenna with IEEE 802.15.4 networking protocol.
- iii. Have 16 specific locations of passive RFID tag.
- iv. Tag location is in a grid pattern.
- v. The path is not disturbed by interferences and blocking caused by obstacle.

1.5 Approach to the study

At the inception of the study, the overall approach has been described as follows: In addition to RFID-based indoor positioning of autonomous aid for disables people, there is several operational scenarios need to be considered. It consists of (1) strategies of RFID deployment (2) the detection method and (3) options to deliver the user's location information and communicating this information to the mobile robot. The RFID deployment and tracking aspects of the scenarios to be examined will include:

- The tradeoffs involved in the selection of RFID devices for this application, including cost, ease of programming, user friendly, and data capacity.
- Use various RFID location reference points to provide data for localization without the use of inertial sensors.
- The emphasis will be to make the maximum use of information and utilize software to facilitate hardware implementation. Aspects of the presentation and communication scenarios investigated include:
 - Notifying the user positions to the mobile robot which consider any communication that is provided by a separate system.
 - The communication system combines RFID reading and wireless network.

1.6 Significance of the study

This project arising from an idea of a difficult or impossible observations for disabled people to move or drive with a conventional wheelchair. This project is a study on the ability and suitability of using RFID technology together with wireless systems in the indoor environment so that it can be applied to improve the mobility aid. Thus, this project will design a self-localization of a mobile robot as a prototype of mobility aid for disabled people using RFID technology with wireless network. With the study of this project, hopefully it can contribute more ideas to improve the mobility aid for disabled people to enhance their range of mobility.

1.7 List of publication

I.S. Zakaria, B.S.K.K. Ibrahim (2012). Localization of Multifunction Electrical Stimulator (FES), National Conference on Engineering Education and Entrepreneurship (NCEEE) 2012, 8-10 May: University Tun Hussein Onn Malaysia (published).



PERPUSTAKAAN
UNIVERSITI TUN HUSSEIN ONN MALAYSIA

CHAPTER 2

LITERATURE REVIEW

Literature review has been conducted prior to undertaking this project to obtain the information of the technology available and the method that used by other researchers on the same topic. This chapter provides the summary of literature reviews on key topics related to the indoor localization techniques.

2.1 Related work

Radio frequency identification (RFID) [14] technology has been utilized in the field of mobile robotics. Recent approaches in the area of mobile robot navigation have evidenced an increasing interest in the emerging RFID technology as a promising alternative due to ease of use, flexibility, and low cost[15].

Byoung-suk Choi et al. [2] reported an improved localization scheme for self-localization of an mobile robot by fusing RFID localization system and ultrasonic measurements. This novel localization system for an indoor mobile robot is proposed to improve the efficiency of the mobile robot system. The system is based on the RFID localization system, which removes the uncertainty of robot location using the distance measurements by ultra-sonic sensors. The RFID system has the same environmental-structure based on tag-floor using passive tags as depicted in Figure 2.1.

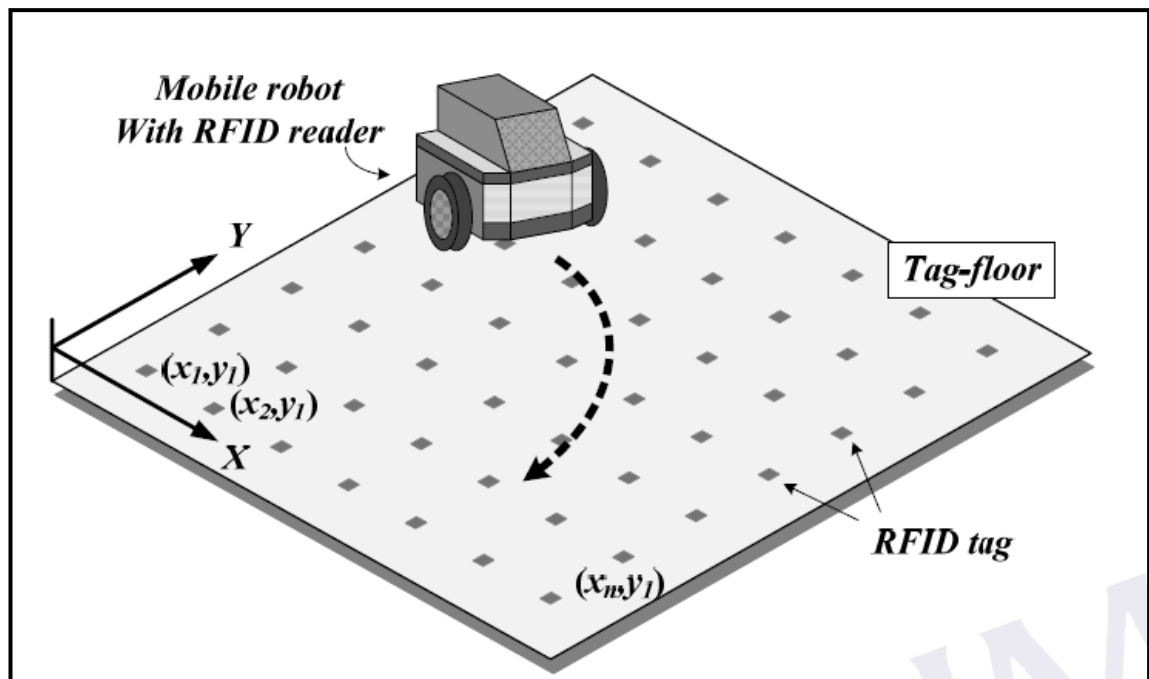

Figure 2.1: Localization system based on tag-floor for an indoor mobile robot [2].

Passive RFID tags are arranged in a fixed pattern on the floor. The absolute coordinates of the location has been stored in each tag to provide the position data to the mobile robot. An RFID reader has been installed to read the tag data on the bottom of the mobile robot. If the robot moves and stays on any tag, the RFID reader reads the coordinate value of RFID tags on the floor to localize the mobile robot. The additional localization system is required to compensate the limitation and uncertainty in an RFID system. In this paper, the additional system used is absolute-localization based on ultra-sonic range sensor system. The ultra-sonic localization systems based on the distance between the robot and environment can provide precise location, therefore they are widely used for mobile robot localization system with geometric algorithm.

Wail Gueaieb et al. [16] presented a navigation system that uses RFID tags. The technique relies on RFID tags placed in 3-D space so that the lines linking their projections on the ground virtually define the “freeways” along which the robot can navigate. The locations of the tags are unknown to the robot. The robot is pre-programmed with an ordered list of tag ID numbers defining its desired path. For instance, if the robot is given the list (4, 9, 1, 5), then it is supposed to navigate to the closest point it can reach to tag number 4, then move in a straight line to the closest

point it can reach to tag number 9, and from there to tag number 1, and then to tag number 5.

The closest point to a tag that the robot can reach is usually the orthogonal projection point of that tag on the ground. During navigation, the robot continuously reads the ID's of all the tags within reach but will only process the signal coming from the destination tag at that time instant. The communication with the tags is performed through an RFID reader with two receiving antennas mounted on the robot. A high-level configuration setup of this system with two RFID tags is depicted in Figure 2.2. In this configuration, the robot's desired path is the straight line segment between the tags' orthogonal projection points on the ground, i.e., A and B.

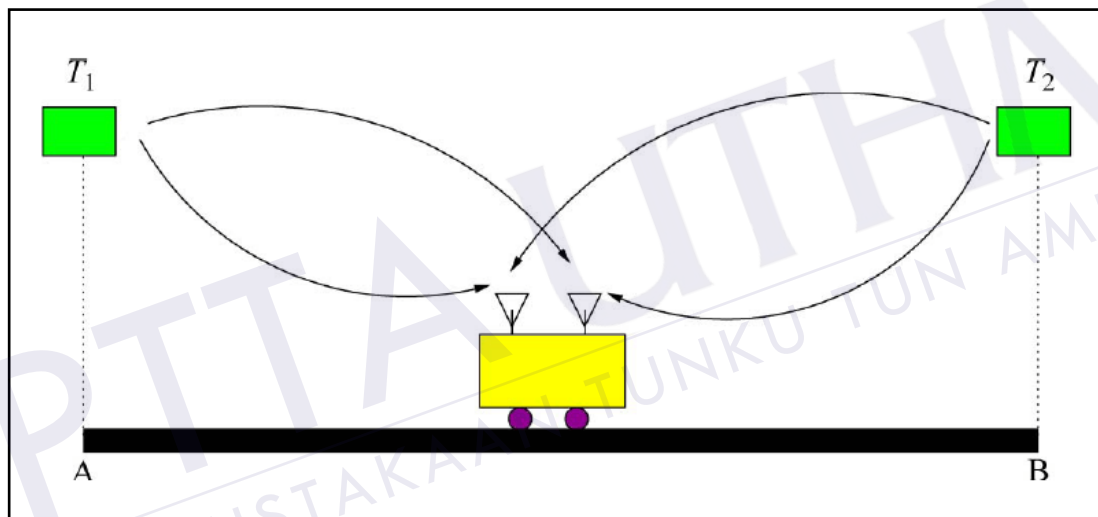

Figure 2.2: High-level system configuration with two RFID tags [16].

Sunhong Park et al. [5] developed a navigation system for mobile robots using passive RFID tags. The mobile robot consists of three main parts which is the personal computer (PC) for control, the RFID system for obtaining the location information of the robot, and the mobile base for navigation. It was developed based on an electric wheelchair for the elderly and disabled persons as a mobility device. The PC mounted on the mobile robot acts as a central controller that handles information of IC tags from the RFID system and sends commands to mobile base in order to reach the goal. The RFID system reads IC tags on the floor which allows the PC to roughly deduce the location and pose of the robot based on the proposed algorithms. Finally, the mobile base is controlled by the PC based on calculations

result from information provided by the RFID system. This mobile robot has external sensors such as distance sensors and touch sensors (bumper switches) for detection of obstacles. The robot's front wheels are free rotating casters, causing some instability when moving.

The size of the antenna in the RFID system must be adjusted in accordance with the distance between IC tags. Circular antenna is constructed to detect IC tags on the 13.56MHz frequency band by using the S6350 Midrange Reader Module. It is possible to read IC tags within 6cm under the antenna. The antenna is attached to the underside of the mobile base, keeping the distance from the antenna to the floor approximately 5cm. The antenna is able to read IC tags which exist within about 17cm from the center of the antenna.

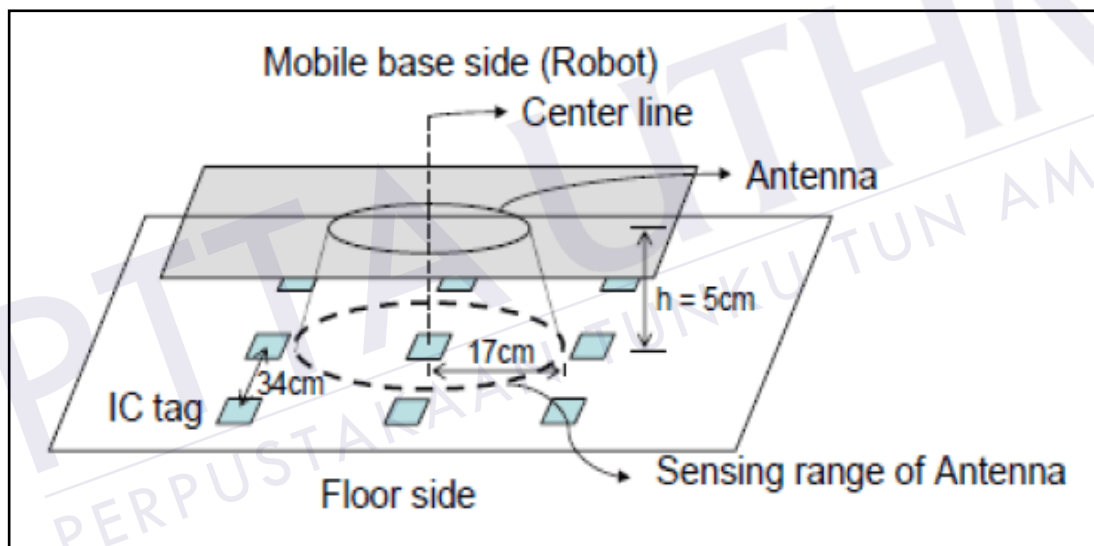

Figure 2.3: Scanning range of the RFID antenna[5].

Takehiro [17] proposed a location estimation system using UHF band RFID, with tags deployed on the ceiling. Location estimation is estimated from the radio field strength of the tag signals received at the readers. This system requires many RFID readers. The RFID used is 950MHz band passive system because it offers the communication over several meters.

Figure 2.4 shows the system outline. Each tag has a unique ID number. Tag IDs of reading tags are transferred to the server. The server has a location information mapping table that pairs each of with its coordinates. The server calculates the reader's position from the coordinates of detecting tags. This position

calculation algorithm is the key advance of this paper. The design target is to not only browse the position information on real-time but also the past data with access via PC and/or mobile phone.

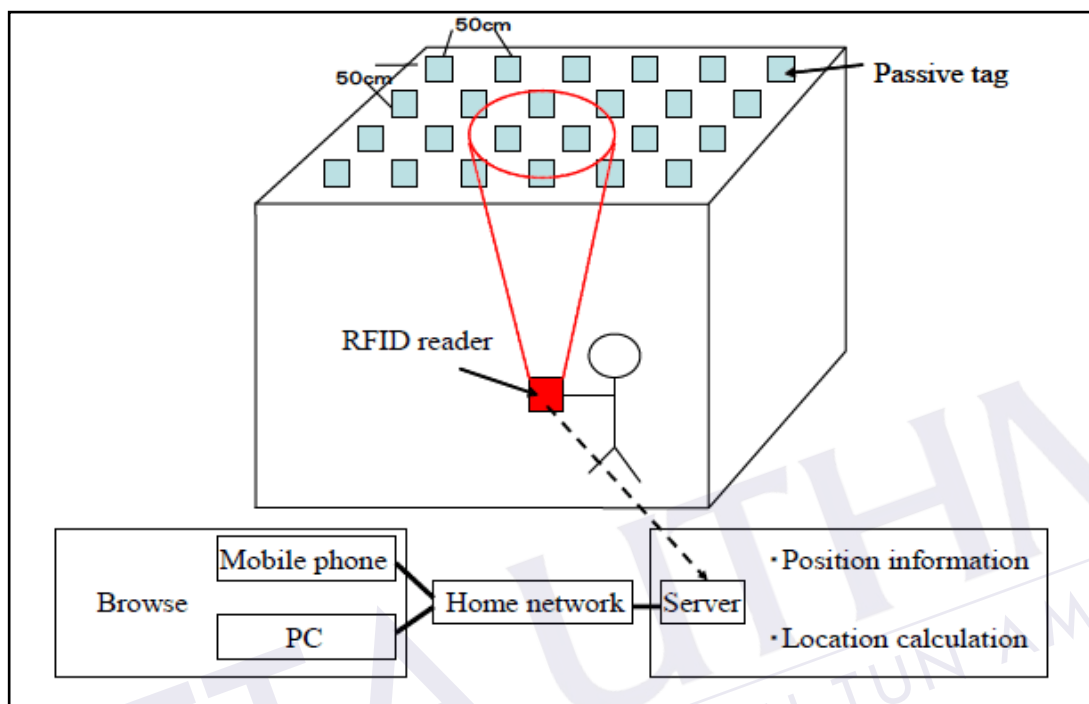

Figure 2.4: Position tracing system [17].

Prathyusha et al. [18] proposed a mobile robot navigation technique using a customized RFID reader with two receiving antennas mounted on the robot and a number of standard RFID tags attached in the robot's environment to define its path. It used the RF signal from the RFID tags as an analogue feedback signal which can be a promising strategy to navigate a mobile robot within an unknown or uncertain indoor environment. The ARM Microcontroller of Microchip LPC 2148 is used to control the autonomous mobile robot to communicate with an RFID reader. By storing the moving control commands such as turn right, turn left, speed up and speed down into the RFID tags beforehand and sticking the tags on the tracks, the autonomous mobile robot can then read the moving control commands from the tags and accomplish the proper actions.

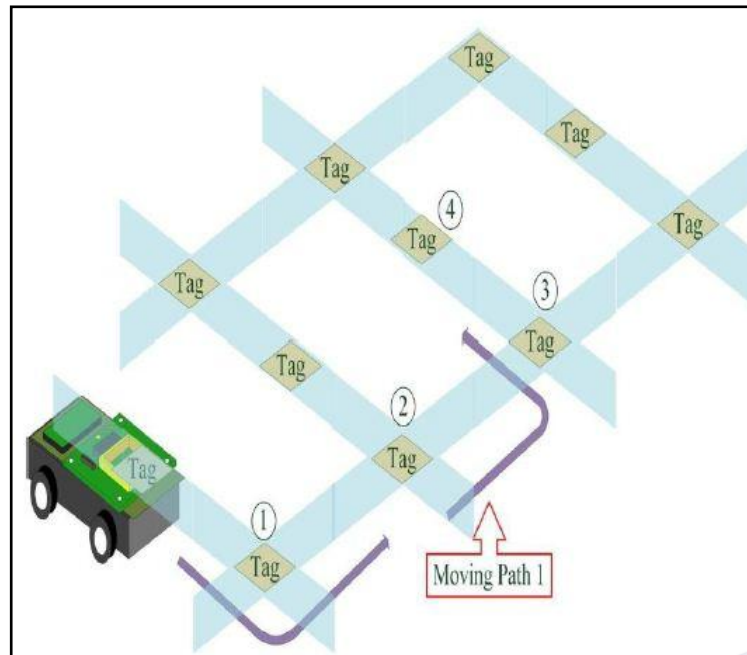

Figure 2.5: Driving circuit for the mobile robot [19].

According to the Figure 2.5, while the robot moves to tag 1 and receives the commands of turn left and speed up, then the ARM microcontroller will make some control actions to let the robot conform the commands [19]. While the robot moves to tag 2, the commands of go straight and slow down were received, the ARM microcontroller will once again make some control actions to let the robot conform the commands. Therefore, the robot will then move in moving path 1 automatically.

2.2 Research comparison

The comparison for each of the previous studies regarding the RFID system in indoor positioning is summarized in Table 2.1.

Table 2.1: Comparison between each research

No.	Research Title	Advantages	Disadvantages
1	An Improved Localization System with RFID Technology for a Mobile Robot (Byoung-Suk Choi, 2008)	More precise location of the robot.	Not economical because required ultrasonic sensor.
2	An Intelligent Mobile Robot Navigation Technique Using RFID Technology (Wail Gueaieb, 2008)	The lines linking the projections on the ground virtually define the “freeways” along which the robot can navigate.	Use active IC tags which require maintenance by humans, such as a periodical battery exchange.
3	Indoor Localization for Autonomous Mobile Robot Based on Passive RFID (Sunhong Park, 2009)	Reduce the localization error without the use of external sensor or a vision system to modify the location of the robot.	PC mounted on the mobile robot and there is no separate system for communication.
4	Indoor Location Estimation Technique using UHF band RFID (Takehiro Shiraishi, 2008)	More cost effective because use the passive tags that do not need any battery which greatly improves serviceability.	Suffers from a variety of obstacles such as lighting fixtures, piping, and ventilation ducts.
5	Design And Development Of A Rfid Based Mobile Robot (Prathyusha, 2011)	Have a moving control command which can speed up or speed down the mobile robot.	Not cost effective because using ARM Microcontroller of Microchip LPC 2148

CHAPTER 3

METHODOLOGY

This chapter will describe the method that will be used for this project in order to achieve the desired objectives. This project development is divided into two phases that is phase A and phase B. Phase A represented the study of the project in semester 1 and phase B will reflect on the design and development of a system that has been studied in phase A. Phase B will be conducted in semester 2. Figure 3.1 compressed the project development.

The project developments shown in Figure 3.1 begin by identifying the problems that exist in indoor positioning. Extensive literature reviews were done on related knowledge to assist in any ways that it may. Such reviews are based on international publications, websites, and engineering books. Detail research in hardware is needed for the robot electrical and electronic development in terms of availability, performance and technical supports. The system requirement was then determined to proceed with this project.

The next step is followed by planning in the design of the hardware and software part of the robot system. The low-level software is an interfacing subroutine for associated components that consist of an XBee wireless module, RFID reader, motor control, and keypad. The interface testing has to be done to ensure the functionality of the hardware and software modules are compatible with the microcontroller. If the tests fail, the problem should be verified either it is due to components or software parameters.

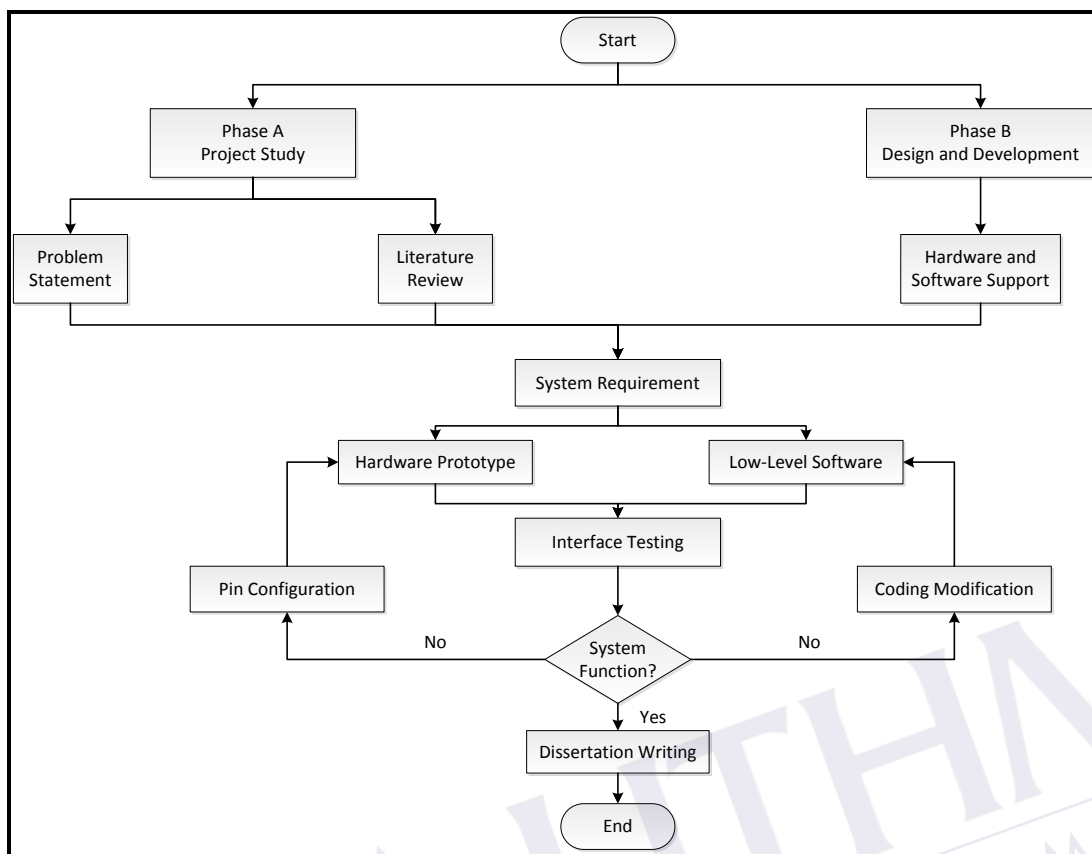

Figure 3.1: Flowchart of project activities.

3.1 System Architecture

Figure 3.2 shows the interface between all devices that will be implemented for this project by using the remote control and mobile robot control setup. The remote control part is used for the user gives the desired location signal to the mobile robot. It will send command to mobile robot in order to reach the desired location of the tag. The input command is coming from the keypad 4x4. While mobile robot control receives the signal from remote control, the RFID reader in mobile robot will start reads IC tags on the floor for obtaining the location information of mobile robots. PIC16F777 will act as a controller that handles information of IC tags on the floor and will determine the path for mobile robot will go through. Connection between remote control and mobile robot control will be made by using the XBee wireless module which provides low transmission power rate and is suitable to use in short range data transmission.

REFERENCES

1. Fernando Seco, C.P., Antonio R. Jiméñez, Wolfram Burgard, *Improving RFID-Based Indoor Positioning Accuracy Using Gaussian Processes*, in *International Conference on Indoor Positioning and Indoor Navigation*. 2010.
2. Byoung-Suk Choi, J.-W.L., Ju-Jang Lee, *An Improved Localization System with RFID Technology for a Mobile Robot*. 2008: p. 3409.
3. Ruixue Li, Z.F., Baocong Hao, Fengjie Yang, *Research on Indoor Wireless Localization System for Radioactive Sources Based on ZigBee*, in *International Conference on Computing, Control and Industrial Engineering*. 2010.
4. Manabu Kosaka, D.W., Ian Swain, *FES Control Design for Paraplegia Using Indoor Rowing Machine*. IEEE Intelligent Systems, 2009: p. 127-132.
5. Sunhong Park, S.H., *Indoor Localization for Autonomous Mobile Robot Based on Passive RFID*. International Conference on Robotics and Biomimetics, 2009.
6. Youngsu Park, J.W.L., Daehyun Kim, Sang-woo Kim. *Improving Position Estimation of the RFID Tag Floor Localization with Multiple Recognition Ranges*. 2011 [cited; Available from: <http://www.intechopen.com/books/advanced-radio-frequency-identification-design-and-applications/improvingposition-estimation-of-the-rfid-tag-floor-localization-with-multiple-recognition-ranges>].
7. Hyeeyeon Chang, J.C., Munsang Kim, *Experimental research of probabilistic localization of service robots using range image data and indoor GPS system*, in *Emerging Technologies and Factory Automation*. 2006.
8. Shi, P.W.M.-C.C.W.-Z., *Research on Data Fusion Algorithm in ZigBee Protocol*. International Symposium on Computer Science and Computational Technology, 2008. 2: p. no., pp.524-527.
9. Ali Montaser, O.M., *RFID Indoor Location Identification for Construction Projects*. 2011, Concordia University: Canada.
10. Dominik Lieckfeldt, J.Y., Dirk Timmermann, *Exploiting RF-Scatter: Human Localization with bistatic passive UHF RFID-Systems*, in *IEEE International Conference on Wireless and Mobile Computing, Networking and Communications*. 2009.
11. Suzuki K., K.Y., Hayashi T., Sakurai T., Hasegawa Y., Sankai Y., *Intention-Based Walking Support for Paraplegia Patient*.
12. Y. Touati, A.A.-C., B. Achili, *Smart Wheelchair Design and Monitoring via Wired and Wireless Networks*. IEEE Symposium on Industrial Electronics and Applications, 2009: p. 920-925.
13. Osamu Matsumoto, K.K., *Autonomous Traveling Control of the "TAO Aidce" Intelligent Wheelchair*, in *International Conference on Intelligent Robots and Systems*. 2006: Beijing, China.

14. Finkenzeller, K., *RFID Handbook: Radio-Frequency Identification Fundamentals and Applications*. 2000: Wiley.
15. L. E. Miller, P.F.W., N. P. Bryner, M. H. Francis, J. R. Guerrieri, D. W. Stroup, L. Klein-Berndt, *RFID-Assisted Indoor Localization and Communication for First Responders*. 2006: National Institute of Standards and Technology (NIST)
16. Wail Gueaieb, M.S.M., *An Intelligent Mobile Robot Navigation Technique Using RFID Technology*. IEEE Transactions on Instrumentation and Measurement, 2008. **57**.
17. Takehiro Shiraishi, N.K., Hiromi Ueda, Hiroyuki Kasai, and Toshinori Tsuboi, *Indoor Location Estimation Technique using UHF band RFID*, in *Proceedings of the ICOIN 2008 international conference on information networking*. 2008.
18. Prathyusha.K, V.H., Dr. S. Balaji, *Design and Developmet of a RFID Based Mobile Robot*. International Journal of Engineering Science and Advanced Technology, 2011. **1**.
19. Jen-Hao, K.-Y.H., Shang-Wen, Luan Rong, Ceng Leo, *RFID-based Autonomous Mobile Car*. IEEE TRANSACTIONS ON INSTRUMENTATION AND MEASUREMENT, 2010.
20. MaxStream, I., *XBee™/XBee-PRO™ OEM RF Modules*. 2006.
21. R.Kousalya, P.M., G.Murugesan, *An Intelligent Mobile Robot Navigation Technique Using RFID Technology*. International Journal of Advanced Engineering Sciences and Technologies. **8**.
22. Sunhong Park, S.H., *Autonomous Mobile Robot Navigation Using Passive RFID in Indoor Environment*. IEEE Transactions on Industrial ELelectronics, 2009. **56**.
23. Dokor Boontrai, T.J., Panarat Cherntanomwong, *Indoor Localization Technique using Passive RFID Tags*. International Symposium on Computer Science and Computational Technology, 2009.
24. *Nokia 3310 Lcd Thermometer Using DS18B20*. 2008 [cited; Available from: <http://www.radiolocman.com/shem/schematics.html?di=44132>].
25. Ishida, S.M., *Ball wheel drive mechanism for holonomic omnidirectional vehicle*. IEEE World Automation Congress (WAC),, 2010.
26. Mark Ashmore, N.B., *Omni-drive robot motion on curved paths: The fastest path between two points is not a straight-line*. IEEE Control Systems, 2010.
27. Sudin, S., *Wireless Knee Joint Angle Measurement System Using Gyroscope*. 2012, Universiti Tun Hussein Onn.