

**OPTIMAL DESIGN OF PASSIVE FILTER TO MITIGATE HARMONIC IN  
POWER FREQUENCY**

**MOHAMAD MILOOD ALMELIAN**

A project report is Submitted In partial  
Fulfillment of the Requirements for The Award of The  
Degree of Master of Electrical Engineering



Faculty of Electrical and Electronic Engineering  
University Tun Hussein Onn Malaysia

**JUNE, 2015**

## ABSTRACT

Nowadays, electricity becomes one of the most important necessities for industrialization increasing living standard of people around the world. Power electronic devices find tremendous applications in industry as well as in domestic appliances. The excessive use of these devices causes major problems in the power system due to generate the harmonics. These harmonics pollute the power system and produce many adverse effect like malfunction of sensitive equipment, reduced power factor, overloading of capacitor, flickering lights, overheated equipments, reduced system capacity etc. One of the methods to mitigate harmonics is by using passive filter. The passive filter concept uses passive components such as capacitors, inductors and resistors which cancel the harmonic components from the nonlinear loads. Passive filter helps the system to improve the power quality and improve reactive power problem. Moreover, it reduces the need of capacitor for supplying extra needed Kvar. This project presents the optimal design of single tuned passive filter that its application is to mitigate harmonics in power frequency. The optimal parameter of this filter was calculated by using LAGRANGE interpolation method. The results were obtained by Matlab/simulation which shows the effectiveness of this filter.

## ABSTRAK

Pada masa kini, elektrik menjadi salah satu keperluan yang paling penting untuk perindustrian bagi meningkatkan taraf hidup masyarakat di seluruh dunia. Kuasa peranti elektronik didapati mempunyai permintaan yang tinggi dalam industri dan juga pada perkakas rumah. Penggunaan berlebihan alat-alat ini boleh menyebabkan masalah utama kepada sistem kuasa kerana generasi harmonik. Harmonik ini mencemarkan sistem kuasa dan menghasilkan banyak kesan buruk seperti kerosakan peralatan sensitif, faktor kuasa dikurangkan, muatan kapasitor, lampu kelipan, peralatan panas, kapasiti sistem dikurangkan dan sebagainya. Salah satu kaedah untuk mengurangkan harmonik adalah dengan menggunakan penapis pasif. Konsep penapis pasif menggunakan komponen pasif seperti kapasitor, induktor dan perintang yang membatalkan komponen harmonik daripada beban tak linear. Penapis pasif membantu sistem untuk meningkatkan kualiti kuasa dan memperbaiki masalah kuasa reaktif. Selain itu ia dapat mengurangkan keperluan kapasitor untuk membekalkan keperluan tambahan Kvar. Projek ini membentangkan rekabentuk optimum penapis pasif tunggal dimana aplikasinya adalah untuk mengurangkan harmonik di dalam frekuensi kuasa. Parameter optimum penapis ini telah dikira dengan menggunakan kaedah interpolasi LAGRANGE. Keputusan yang telah diperolehi oleh Matlab/simulasi menunjukkan keberkesanan penapis ini.

## CONTENTS

<b>TITLE</b>	ii
<b>DECLARATION</b>	iii
<b>DEDICATION</b>	iv
<b>ACKNOWLEDGMENTS</b>	v
<b>ABSTRACT</b>	vi
<b>ABSTRAK</b>	vii
<b>CONTENTS</b>	viii
<b>LIST OF TABLES</b>	xi
<b>LIST OF FIGURES</b>	xii
<b>LIST OF SYMBOL AND ABBREVIATIONS</b>	xiv
<b>LIST OF APPENDICES</b>	xvi
<b>CHAPTER 1 INTRODUCTION</b>	<b>1</b>
1.1 Introduction	1
1.2 Problem statement	2
1.3 Objectives	2
1.4 Scope	2
1.5 Structure of master project report	3
<b>CHAPTER 2 LITERATURE REVIEW</b>	<b>4</b>
2.1 Introduction	4
2.2 Harmonics	5
2.2.1 Harmonic standards	5
2.2.1.1 IEEE Standard 519	5

2.2.1.2	IEC 61000-3 Standard	7
2.2.2	Harmonic Order	8
2.2.3	Source of Harmonic	9
2.2.4	Effect of Harmonics	10
2.4.4.1	Effect on Transformer	10
2.4.4.2	Effect on Capacitor bank	11
2.4.4.3	Neutral conductor over loading	11
2.4.4.4	Effect on lines and cables	12
2.4.4.5	Thermal effect on rotating machine	12
2.4.4.6	Undesired operation of fuse	12
2.3	Harmonic Reduction	13
2.4	Passive filter	14
2.4.1	Filter design constraints	17
2.4.2	Classification Of Passive Filters	17
2.4.2.1	Passive Series Filter	17
2.4.2.2	Passive Shunt Filter	18
2.4.3	Type Of Passive Filters	19
2.4.4	Compensation Principle of Passive Shunt Filters	21
2.5	Previous Research	23
<b>CHAPTER 3 METHODOLOGY</b>		<b>28</b>
3.1	Introduction	28
3.2	Methodology	29
3.3	Design of three phase non-linear load system	31
3.4	optimal Passive Filter Design	31
3.4.1	Single Tuned Passive Filter Design	32
3.5	LAGRANGE interpolation method	33
3.6	Nonlinear Load without and with passive filter	35
3.7	Procedure to design single tuned passive filter parameters for non-linear load test system	37



<b>CHAPTER 4 RESULT AND ANALYSIS</b>	<b>39</b>
4.1 Introduction	39
4.2 Simulation results and analysis	40
4.2.1 Linear load system	40
4.2.2 Non-linear Load without single tuned passive filter	42
4.2.3 Non-linear Load with single tuned passive filter	45
<b>CHAPTER 5 CONCLUSION AND RECOMMENDATION</b>	<b>49</b>
5.1 Conclusion	49
5.2 Recommendation	50
<b>REFERENCES</b>	<b>51</b>
<b>APPENDIX A</b>	<b>54</b>
<b>APPENDIX B</b>	<b>56</b>
<b>APPENDIX C</b>	<b>59</b>



PTTA UTHM  
PERPUSTAKAAN TUNKU TUN AMINAH

## LIST OF TABLES

2.1	Current distortion limits (in % of $I_L$ ) for general distribution system (120-69kV)	6
2.2	Voltage Distortion Limits (in % of $V_1$ )	6
2.3	THD Limits from IEC 61000-3-2 and 61000-3-4	7
2.4	Comparison of different types of filters	13
2.5	Comparison of different types of passive filter	20
2.6	Previous Research	23
3.1	Parameters of Test system	36
3.2	Reactive power of single tuned passive filter and THD on test system	37
3.3	Excel worksheet result	38
3.4	Parameters of single tuned passive filter	38
4.1	Harmonic values of line current without single passive filter	45
4.2	Harmonic values of line current with single passive filter	48

## LIST OF FIGURES

2.1	IEC Harmonic Limits as a Function of Wattage	8
2.2	Resultant waveform of system having 3 <sup>rd</sup> , 5 <sup>th</sup> and 7 <sup>th</sup> harmonics	9
2.3	Low and High pass passive filters	15
2.4	Characteristic of cutoff frequency of Low and High Pass Filters	16
2.5	Block diagram of basic passive filter operation	16
2.6	Schematic diagram of passive series filter	18
2.7	Schematic diagram of passive shunt filter	19
2.8	Type of Passive Filter	19
2.9	Equivalent circuit diagram of passive tuned shunt filter	21
3.1	Thesis Flowchart	29
3.2	Three phase non-linear load	31
3.3	Single Tuned filter	32
3.4	Interpolation of discrete data	34
3.5	6-pulse diode Rectifier	35
3.6	Test System without passive Filter	35
3.7	Test System with passive Filter	36
4.1	Three phase linear load system	40
4.2	Voltage source waveform of linear load system	41
4.3	Current source waveform of linear load system	41
4.4	Voltage source waveform of non-linear system without passive filter	43



4.5	Current source waveform of non-linear system without passive filter	43
4.6	Line current analysis without passive filter	44
4.7	Non-linear system with designed single tuned passive Filter	46
4.8	Source current waveform of non-linear load system with designed single tuned passive filter	46
4.9	Line current analysis with designed single tuned passive filter	47



## LIST OF SYMBOL AND ABBREVIATIONS

PS	-	Power System
THD	-	Total Harmonic Distortion
AC	-	alternating current
DC	-	Direct current
PCC	-	point of common coupling
IEEE	-	Institute of Electrical and Electronics Engineers
IEC	-	International Electro technical Commission
<b>h</b>	-	Harmonic order
$I_{sc}$	-	Available short circuit current
$I_L$	-	15 or 30 minute (average) maximum demand current
TDD	-	Total demand distortion
$I_1$	-	Fundamental current
$I_h$	-	Harmonic current
$THD_I$	-	Total Harmonic Distortion for current
$TDD_I$	-	Total Demand Distortion for current
$THD_v$	-	Total Harmonic Distortion for voltage
$V_1$	-	Fundamental voltage
$V_h$	-	Harmonic voltage
A	-	Ampere
W	-	Watt
UPS	-	Uninterruptible power supplies
RMS	-	Root mean square

$I_{rms}$	-	RMS value current
$I_0$	-	Peak value current
V	-	volt
$\tau$	-	Time constant
$f_c$	-	Cutoff frequency
R	-	Resistor
C	-	Capacitor
L	-	Inductor
$Z_{sh}$	-	Impedance of parallel RLC filter
$Z_L$	-	load impedance
$Z_S$	-	Line impedance
$V_L$	-	Output voltage
$V_S$	-	Input voltage
$I_L$	-	load current
$I_F$	-	Filter current
$I_S$	-	Input current
$L_S$	-	Inductive line
SCR	-	Silicon controlled Rectifier
$Q_C$	-	capacitive reactive power
$X_C$	-	capacitor reactance
kV	-	nominal line to line voltage by kilovolt
$X_L$	-	inductor reactance
Q	-	quality factor of filter
$X_n$	-	characteristic reactance
$Z_F$	-	Filter impedance
HZ	-	Hertz
$\Omega$	-	Ohm
$V_{rms}$	-	RMS value voltage
H	-	Henry
var	-	Volt-ampere reactive
FFT	-	Fast Fourier Transform

**LIST OF APPENDICES**

<b>APPENDIX</b>	<b>TITLE</b>	<b>PAGE</b>
A	GANTT CHART OF MASTER'S PROJECT	54
B	TOOLS OF SOFTWARE	56
C	MATLAB/Simulink DOCUMENTATION FOR SIMULATION MODEL	59



**PTTA UTHM**  
PERPUSTAKAAN TUNKU TUN AMINAH

## CHAPTER 1

### INTRODUCTION

#### 1.1 Introduction

Harmonic signal can be described as signal whose frequency in multiple occupy with the reference signal, which mean current and voltage will multiple continues of the fundamental frequency. In mathematical view, it is described as the ratio of the frequency of such a signal to the frequency of the reference signal [1].

Harmonic signal can cause several malfunction in electric equipment such as, distortion in the voltage, current waveform, excessive current on neutral wire, overheating of the motor, microprocessor problem and unexplained computer crash. In terms of industrial sectors, harmonic causes higher transformer losses ,line losses, reactive power and resonance problems, harmonic interactions between customers or between the utility and load.

Basically, the common source of harmonic signal is nonlinear load. It is due to the fact that current does not very smoothly with voltage. Nonlinear load such as fluorescent lamp, electric welding machine and three-phase rectifier generates primarily 5th and 7th current harmonic and some of higher order harmonic.

The harmonic signal cannot be totally eliminated, but it can be reduced by several ways. One of the technique is by using passive filter The most common practice for harmonic mitigation is the installation of passive harmonic filters.

Passive filters exhibit the best relationship cost-benefit among all other mitigation techniques when dealing with low and medium voltage rectifier system [2]. They supply reactive power to the system while being highly effective in attenuating harmonic components.

## 1.2 Problem statement

In a power system (PS), the three-phase is used to supply line loads. Operation of three-phase nonlinear load causes harmonic effect on PS. Harmonic voltages cause voltage distortion in PS. Meanwhile, harmonic current provide power that still can be used but with some losses called as harmonic distortion.

The 5<sup>th</sup> and 7<sup>th</sup> harmonics are the troublesome harmonic components, especially in the industrial PS. If the total harmonic distortion (THD) increases to a particular percentage level, it could cause permanent damage to the equipments.

Nowadays, many countries set limits for the harmonic distortion in the distribution networks, this harmonic distortion can be mitigated by using filters. So in this project optimal design of passive filter is crucial to make sure it mitigates the harmonic component.

## 1.3 Objectives

The objectives of this research are:

- (a) To design an optimal single tuned passive filter by using MATLAB.
- (b) To mitigate harmonics in power frequency.

## 1.4 Scope

- (a) The main focus in this project to design a single tuned passive filter for mitigating harmonics.
- (b) Study on constructing harmonic filter by using MATLAB / simulink .
- (c) Using Fast Fourier Transform (FFT) method to find THDi by using MATLAB / simulink.

- (d) Graphical result and comparing the result before and after installation the harmonic filter by using MATLAB / simulink.

### **1.5 Structure of master project report**

This report is structured and organized as follows:

Chapter 1 (Introduction) -This chapter explains the introduction of the project, problem statements, objectives, scope of study, and the structure of the master project.

Chapter 2 (Literature Review) - This chapter discuss about a journal that associate with this project. Harmonics phenomena, common source of harmonics, and the effect of harmonic signal.

Chapter 3 (Methodology) -The methodology explains clearly and details about how this project was conducted, This chapter will review about the designation of passive filter.

Chapter 4 (Result and Analysis) -This chapter shows the simulation results and brief discussion on the results obtained.

Chapter 5 (Conclusion and Recommendation) -In this chapter, a conclusion for the whole project based on the finding of the results was conducted.



## **CHAPTER 2**

### **LITERATURE REVIEW**

#### **2.1 Introduction**

This chapter explains and discusses on harmonic phenomena, sources, effects and reduction. Besides that, this chapter is also including the harmonic filters, the advantage, disadvantage, and application of different types of harmonic filters, and the Comparison of different types of passive filter. Several journals are also included in this chapter to have an overview about the harmonics and method of mitigation.



PTM  
PERPUSTAKAAN TUNJUKKAN



## 2.2 Harmonics

Harmonics are the integral multiples of fundamental frequency resulting in the distortion of supply waveform. Harmonics are defined as the sinusoidal components of a repetitive waveform which consist of frequencies that are exact multiples or harmonic orders of fundamental frequency.

A complete set of harmonics then makes up a Fourier series which together represent the original waveform. Harmonics are currents, usually in multiples of the supply fundamental frequency, produced by non-linear loads such as the AC to DC power conversion circuits. For example a 50 Hz supply, the 5th harmonic is 250 Hz, 7<sup>th</sup> harmonic is 350 Hz and so on [3].

### 2.2.1 Harmonic standards

There are two most important international harmonic standards, (American standard) IEEE 519 and (European standard) IEC 61000-3 [10,11].

#### 2.2.1.1 IEEE Standard 519

To assist the integrity of the PS, the IEEE issued an IEEE 519-1981 standard, “Guide for applying harmonic limits on PS,” which was first published in 1981. The updated version IEEE 519-1992, “Recommended practices and requirements for harmonic control in Electric PS,” is published in 1992. IEEE 519-1992 addresses current distortion permitted at the utility interface while IEEE 519-1981 standard focused on the issue of the system voltage distortion. The reason is that the current distortion is the root cause of voltage distortion. IEEE 519 which is the most often quoted American standard attempts to establish reasonable current/voltage harmonic goals at the point of common coupling (PCC) for electrical systems that contain nonlinear loads. IEEE 519 explains how harmonics are generated, the effects of harmonics, solutions to harmonic problems, measurement techniques, and recommended limits on harmonic generation for both electric utilities and their customers [10]. The recommended harmonic current limits from IEEE 519 are given in table 2.1.

**Table 2.1:** Current distortion limits (in % of  $I_L$ ) for general distribution system (120-69kV)

$I_{SC} / I_L$	<11	11≤h<17	17≤h<23	23≤h<35	35≥h	TDD
< 20	4	2	1.5	0.6	0.3	5
20 - 50	7	3.5	2.5	1	0.5	8
50 - 100	10	4.5	4	1.5	0.7	12
100 - 1000	12	5.5	5	2	1	15
> 1000	15	7	6	2.5	1.4	20

Where  $I_{SC}$ : Available short circuit current,  $I_L$ : 15 or 30 minute (average) maximum demand current. TDD: Total demand distortion. TDD is identical to THD except  $I_L$  is used instead of the fundamental current component. It is important to note that Table 2.1 shows limits for odd harmonics only [10].

$$THD_I = \frac{1}{I_1} \sqrt{\sum_{h=2}^{\infty} I_h^2} \quad (2.1)$$

$$TDD_I = \frac{1}{I_L} \sqrt{\sum_{h=2}^{\infty} I_h^2} \quad (2.2)$$

Where:  $THD_I$  is Total Harmonic Distortion for current,  $TDD_I$  is Total Demand Distortion for current,  $I_1$  is the fundamental current,  $I_h$  is the harmonic current. Based on the harmonic current limit given in Table 2.1, it is assumed that the voltage levels will not exceed those given in Table 2.2.

**Table 2.2:** Voltage Distortion Limits (in % of  $V_1$ )

PCC Voltage	Individual Harmonic Magnitude (%)	THDv
≤ 69 kV	3	5
69 Kv-161 kV	1.5	2.5
≥ 161 kV	1	1.5

$$THD_v = \frac{1}{V_1} \sqrt{\sum_{h=2}^{\infty} V_h^2} \quad (2.3)$$

Where:  $THD_v$  is Total Harmonic Distortion for voltage,  $V_1$  is the fundamental voltage,  $V_h$  is the harmonic voltage.

### 2.2.1.2 IEC 61000-3 Standard

The IEC 61000-3-2 describes the general requirements of harmonic current emissions and voltage fluctuations of electrical equipment with line currents lower than 16 A per phase. For the purpose of harmonic current limitation, the standard divides electrical equipment into four classes. IEC 61000-3-4 is applied for line currents greater than 16 A per phase. The table 2.3 shows what the resulting current THD limit is for a 220 V device [11].

**Table 2.3:** THD Limits from IEC 61000-3-2 and 61000-3-4

Wattage	THD Limit (%)
< 600	90
1000 – 1500	60
> 3500	26

Figure 2.1 shows the same information contained in the table 2.3 but also shows the linear decline between intervals (i.e., between 600 W and 1000 W, and between 1500 W and 3500 W).



**Figure 2.1:** IEC Harmonic Limits as a Function of Wattage

Finally, the harmonic limits of IEC 61000-3 are based on product level at the terminals of end-user equipment while those of IEEE 519 are based on the interactions between facilities and the public distribution system. The main reason for these harmonic standards which are still evolving is to limit harmonic emissions from electronic equipment in order to protect other loads and components of the PS [10,11].

### 2.2.2 Harmonic Order

In the electrical system various type of harmonics are present which are given by their order. Harmonic order or harmonic number is a reference to the frequency of the harmonic component.

The order of harmonics [4] is given by equation (2.4).

$$f_h = (h) * \text{fundamental frequency or line frequency} \quad (2.4)$$

Where  $h$  = Integer value

So now if we had considered ideal condition that system has frequency of 50 Hz is with a peak value of 100 Amp current along the system. This 100 Amp value is also consider as one per unit. Likewise this per unit the harmonics would have same waveform of order of  $(1/3)$   $(1/5)$   $(1/7)$  of fundamental waveform or amplitude. Figure 2.2 shows the harmonic order is inverse to the amplitude of fundamental frequency.

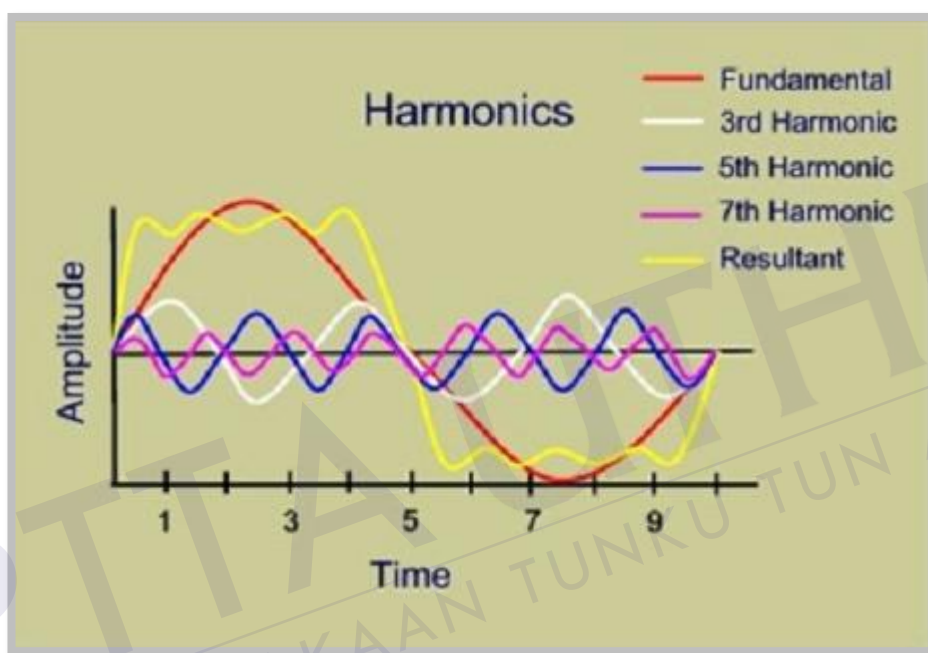

**Figure 2.2:** Resultant waveform of system having 3<sup>rd</sup>, 5<sup>th</sup> and 7<sup>th</sup> harmonics

### 2.2.3 Source of Harmonic

The main harmonics sources can be divided into two categories.

- i. Non linear loads (i.e: speed drives ).
- ii. Static power converters and transmission system level power electronic devices (i.e: switch-mode power supplies, voltage source converters).

A nonlinear component consists of single phase diode bridge rectifiers and the power supply. Power electronic loads draw power only during portions of the applied current waveform. For the industrial load, which is mainly three wire system,

the Uninterruptible power supplies (UPS) produces harmonics between the phases and produced the imbalanced system [4].

#### **2.2.4 Effect of Harmonics**

Harmonics are a major cause of power supply pollution lowering the power factor and increasing electrical losses. The effect of harmonic results in premature equipment failure and also cause of requirement of equipment of high rating. The voltage distortion produced in the system is the major issue with the harmonics distribution. The electronics equipment used in the system usually generate harmonics more than one. In all type of harmonics the tripled harmonics are more severe example of triplet harmonics are 3<sup>rd</sup> 9<sup>th</sup> 15<sup>th</sup> [5].

These harmonics creates a big challenge for engineers because they poses more distortion in voltage. The effect of triplex harmonics come with overheating in wires, overheating in transformer units and also may become the cause of end user equipment failure. Triplex harmonics overheat the neutral conductor of 4 wire system. the neutral have generally no fundamental frequency or even harmonics but there may be existence of odd harmonics in system neutral conductor and when there is system consist of triplex harmonics it is become additive. These triplex frequency impact on the system can be understand by this way that even under balanced load condition on the account of triplex frequency neutral current magnitude reaches up to 1.75 times of average phase current [6]. Under above discussed case if the load of system increase may become cause of failure of insulation of neutral conductor which further result in the breakdown of transformers winding. The important and major effect of Harmonics is further discussed as:

##### **2.2.4.1 Effect on Transformer**

Harmonics effect transformer losses and eddy current loss density [7]. Actually, the harmonic effects on transformer will not be notice until actual failure occurs. It will occurs when there has been changes that been made to the system like additional or replacement of new loads. Overheating of transformer is always been related with harmonics effects.

Harmonics produce addition losses in the transformer core as the higher frequency harmonic voltages set up hysteresis loops, which superimpose on the fundamental loop. Each loop represents higher magnetization power requirement and higher core losses.

Because of harmonics, the losses in conductor will increase. The resultant current will increase the distortion and is given by equation (2.5).

$$I_{rms} = \sqrt{1 + (THD_I)^2} \quad (2.5)$$

Where:  $I_0$  (Peak value current) =  $\sqrt{2} I_{rms}$

$I_{rms}$ : is RMS value current

Overheating also can occur when there is resistive skin effect and winding proximity effect [1].

#### 2.2.4.2 Effect on Capacitor bank

In industrial load where a lot of motors are used, we need to improve power factor. For this purpose we are connected capacitor banks near to the loads to improve it. Since harmonics create reactance as for capacitor reactance will increase as the frequency decrease. Therefore, the linear loads served from a common feeder, which also serves nonlinear loads of some other consumers, may become susceptible to harmonic distortion. Moreover, a consumer's system which does not have harmonics can be subjected to harmonic pollution due to of other consumers in the system. The capacitors can be severely overloaded due to harmonics and can be damaged [7].

#### 2.2.4.3 Neutral conductor over loading

In single phase PS neutral play a very important role as they carry the return current and complete the circuit. But in case of harmonics it also becomes the return path for the harmonic current to transformer through neutral connection. For an unbalanced system the unbalanced currents are passed through the neutral and for this purpose we need to balance the system the size of neutral cable is almost taken equal to its

phase cable. Under environment of harmonics the unbalanced current which is passed through the neutral produces a heat loss in the system which again affects the power quality of distribution system [4].

#### **2.2.4.4 Effect on lines and cables**

Harmonic distortion in a distribution system affects the system current and significantly. These increased rms currents produce additional heat losses in the system lines and cables. Harmonic distortion in cables affect by increasing the dielectric stress in the cables. This stress is proportional to the voltage crest factor which represents the crest value of voltage waveform to rms value of waveform. The effect of this increased stress is such that, the cable useful life is shortened, causing faults, which ultimately increases the system capital and maintenance cost [6].

#### **2.2.4.5 Thermal effect on rotating machine**

Rotating machine are also affected by harmonics same as transformer. Resistance of rotating machine will go high if the frequency of system is high. For this if there is harmonic present in the system have a very rich current value which tends to produce a heat loss in the rotating machine . This overall heat loss will again affect its life and thus increase maintenance problems [8].

#### **2.2.4.6 Undesired operation of fuse**

In the environment of harmonic the RMS value of voltage and current may increase. This tendency will lead the problem of unexpected operation of fuse in capacitor banks or other arrangements which are used in the system to make operation of nonlinear load. If the fuse of one connected phase blown off then the other remaining fuse is in operation under a stress. In this condition the system become unbalanced and it will tends to produce the overvoltage in the system. To summarize above discussion it is concluded that, the following problems arise due to harmonics [8].

- i) Equipment overheating
- ii) Equipment malfunction or operation failure of equipment
- iii) Equipment failure



- iv) Communications interference
- v) Fuse and breaker operation failure
- vi) Maintenance problem

### 2.3 Harmonic Reduction

There are various kinds of methods to reduce harmonics signal such as, oversize the neutral conductor, use separate neutral conductors and harmonic filters. Filters are designed to suppress system harmonics as well as to improve power factor. There are two common type of filters; passive filter and active filter. Table 2.4 shows comparison of different types of filters used for harmonic mitigation [4].

**Table 2.4:** Comparison of different types of filters

Type of filter	Passive filter	Active filter	Hybrid filter
<b>Advantages</b>	<ul style="list-style-type: none"> <li>* no power supply required.</li> <li>* can handle large currents and high voltages.</li> <li>* very cheap</li> </ul>	<ul style="list-style-type: none"> <li>* generally easier to tune.</li> <li>* no inductors</li> <li>* small in size and weight</li> </ul>	<ul style="list-style-type: none"> <li>* very reliable</li> <li>* can produce high gains.</li> </ul>
<b>Disadvantages</b>	<ul style="list-style-type: none"> <li>* limited standard sizes, often requiring variable inductors and therefore tuning.</li> <li>* generally not amenable to miniaturization</li> </ul>	<ul style="list-style-type: none"> <li>* power supply require</li> <li>* susceptible to inter modulation, oscillations</li> </ul>	<ul style="list-style-type: none"> <li>* required many components</li> <li>* Very expensive</li> </ul>

Type of filter	Passive filter	Active filter	Hybrid filter
<b>Application</b>	* Industrial installations with a set of non-linear loads representing more than 500 kVA (variable-speed drives, UPSs, rectifiers, etc.) * Installations where current distortion must be reduced to avoid overloads	* Commercial installations with a set of non-linear loads representing less than 500 kVA (variable-speed drives, UPSs, office equipment, etc.) * Installations where current distortion must be reduced to avoid overloads	* Industrial installations with a set of non-linear loads representing more than 500 kVA (variable-speed drives, UPSs, rectifiers, etc.) * Installations where voltage distortion must be reduced to avoid disturbing sensitive loads

#### 2.4 Passive filter

Power distribution system is designed to operate with sinusoidal voltage and current waveform at constant frequency. However, when non linear load like thyristor drives, converters and arc furnace are connected to the system, excessive harmonic currents are generated and this causes both current and voltage distortions. From the table 2.4, it is concluded that, the passive filter is the best way to eliminate the distortion in distribution power system [5].

A filter in the most common sense is something that removes an unwanted feature, or aspect of something. In signal processing and engineering the only difference is that the unwanted component may be voltage or current harmonics. Figure 2.3 (a) and (b) shows the basic low and high pass filters respectively.

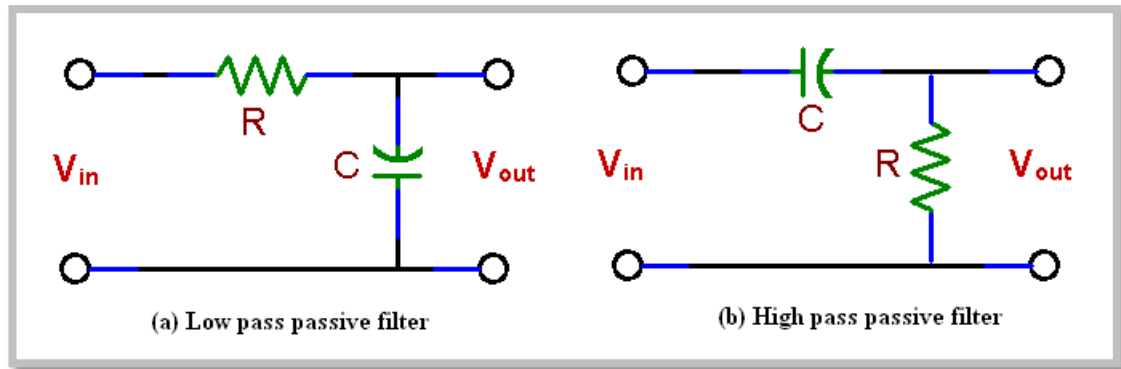

**Figure 2.3:** Low and High pass passive filters

These filters pass low or high frequencies regardless of whether it is a fundamental or a  $n^{\text{th}}$  harmonic (where  $n$  is any integer number). This means that these filters, known to be part of the class of passive filters, can be used to filter out higher order frequencies. These filters have an element known as a time constant which is often equal to the resistance multiplied by the capacitance “RC” connection. This time constant is called  $\tau$ .

$$\tau = RC \quad (2.6)$$

The cutoff frequencies of the filters are directly dependent on this constant. A simple equation to represent the cutoff frequencies for both the basic high and low pass RC filters is shown in Equation (2.7) [13].

$$f_c = \frac{1}{2\pi RC} \quad (2.7)$$

$$RC = \frac{1}{2\pi f_c} \quad (2.8)$$

$$\tau = \frac{1}{2\pi f_c} \quad (2.9)$$

The characteristic of cutoff frequency of both low and high pass filter is shown in figure 2.4

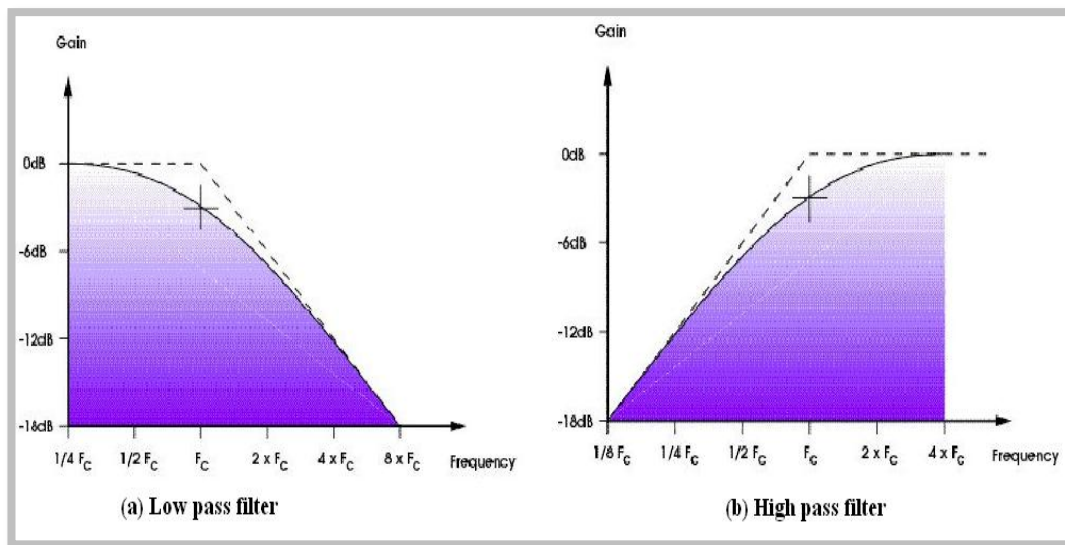

**Figure 2.4:** Characteristic of cutoff frequency of Low and High Pass Filters

Figure 2.5 shows the diagram of basic passive filter operation in power system network.

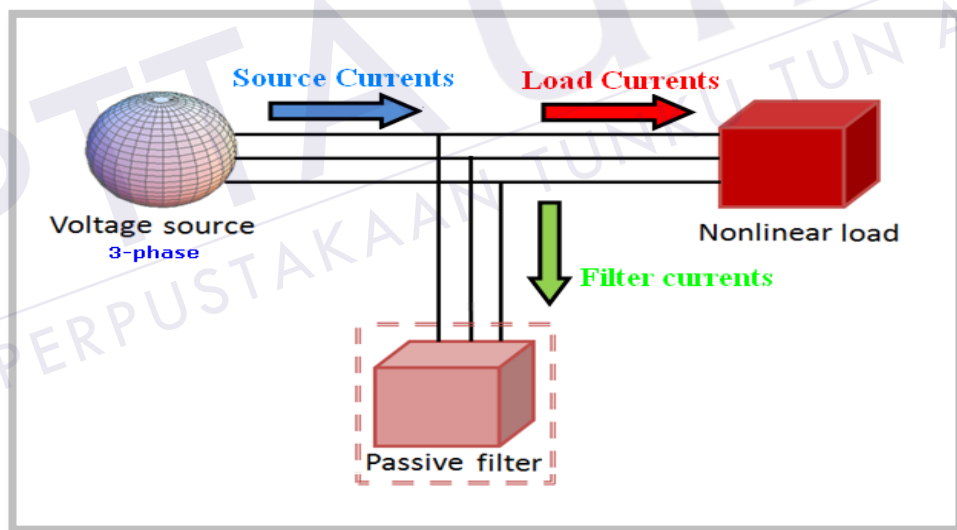

**Figure 2.5:** Block diagram of basic passive filter operation

This project will present a design of a passive filter to mitigate harmonics in power frequency. It focuses on the performance of passive filter through non linear loads. The calculation of design passive filter for this project is represented in chapter 3.

### 2.4.1 Filter design constraints

There are various issues in the design of a passive filter for its proper functioning in harmonic reduction. The key issues are mentioned here:

a) Minimizing harmonic source current:

The prime objective of the filter design is to minimize the harmonic current in ac mains. This is ensured by minimizing the filter impedance at the harmonic frequencies so that the harmonic filter acts as a sink for the harmonic currents.

b) Minimizing fundamental current in passive filter:

To ensure that the installation of passive filter does not cause the system loading, the fundamental current in the passive filter is minimized by the maximizing the passive filter impedance at the fundamental frequency.

c) Environment and ageing effect:

The capacitors with metalized film construction lose capacitance as they age. Similarly the manufacturer tolerance of the harmonic filter reactor may result in tuned frequency higher than the nominal. An IEEE Standard 1531 [6] recommends that the passive filters are tuned at 6% below the rated frequency so that it will exhibit acceptable tuning at the end of its 20 year life.

### 2.4.2 Classification Of Passive Filters

Depending on the connection of different passive components, the passive filters can be broadly classified in two categories as given below.

#### 2.4.2.1 Passive Series Filter

For voltage source type of harmonic loads (such as diode rectifier with R-L load filter), passive series filter is considered as a potential remedy for harmonic mitigation [16]. Here, the different tuned branches of passive filters are connected in series with the supply and the diode rectifier. Figure 2.6 shows the schematic diagram of a passive series filter connected at input ac mains. It consists of a set of low block tuned shunt filter tuned at 5th and 7th harmonic frequencies and high block tuned filter for 11th harmonic frequency. These passive filters blocks most dominant 5th, 7th and other higher order harmonics and thus prevents them from

flowing into ac mains. Here, the performance of the series filter is not much dependent on the source impedance. However, it results in reduction in dc bus voltage due to voltage drop across filter components.

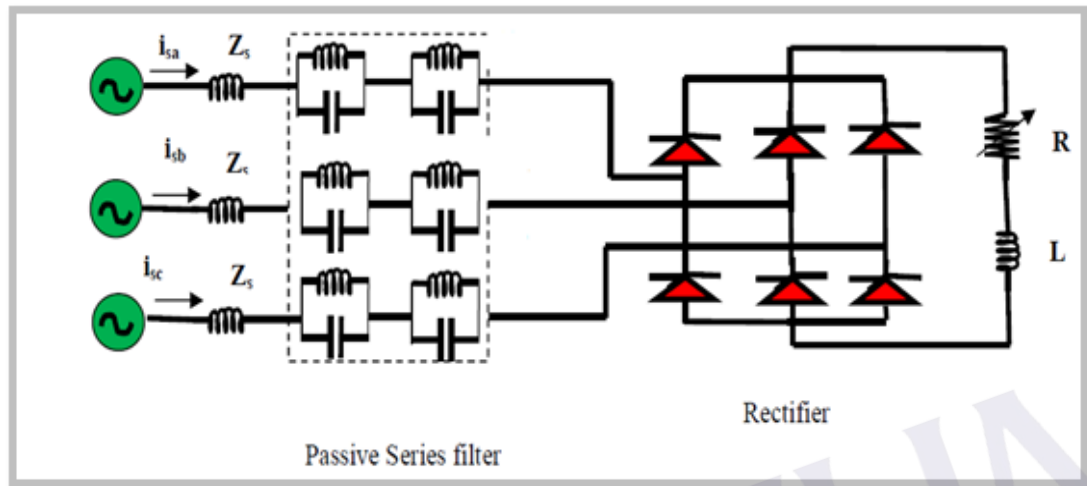

**Figure 2.6:** Schematic diagram of passive series filter

#### 2.4.2.2 Passive Shunt Filter

It is the most common method for the cancellation of harmonic current in the distribution system. Passive harmonic filter are basically designed on principle of either single tuned or band pass filter technology. As the name suggests shunt type filter are connected in system parallel with load. Passive filter offer a very low impedance in the network at the tuned frequency to divert all the related current and at given tuned frequency. Because of passive filter always have tendency of offering some reactive power in the circuit so the design of passive shunt filter take place for the two purpose one is the filtering purpose and another one is to provide reactive compensation purpose of correcting power factor in the circuit at desired level. The advantage with the passive shunt type filter is that it only carry fraction of current so the whole system AC power losses are reduced compare to series type filter. The given figure 2.7 shows the schematic diagram of 6 pulse converter system connected with shunt passive type filter which are simply employed ever connection in distribution system have R-L load in system [16].

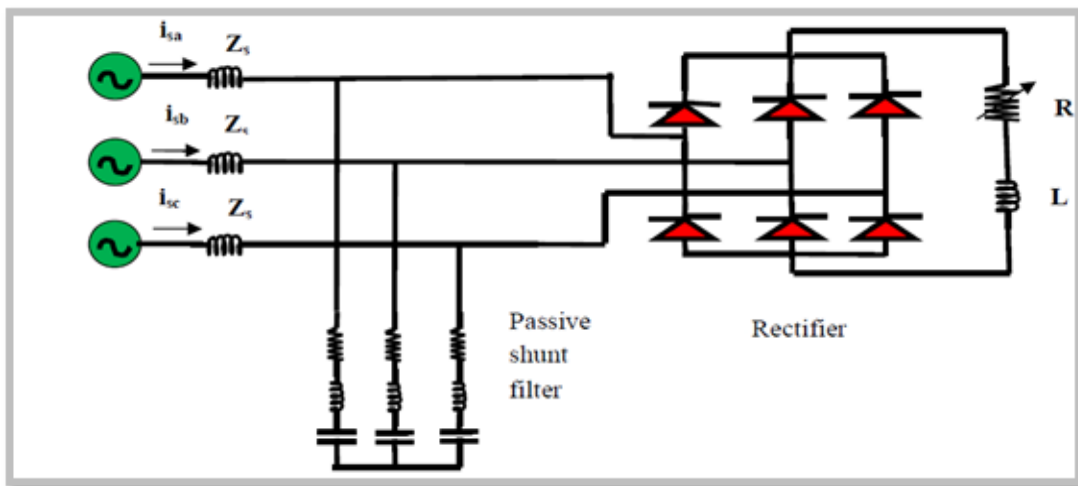

Figure 2.7: Schematic diagram of passive shunt filter

### 2.4.3 Type Of Passive Filters

There are several type of passive filters, the most commonly filter types as shown in figure 2.8 [7].

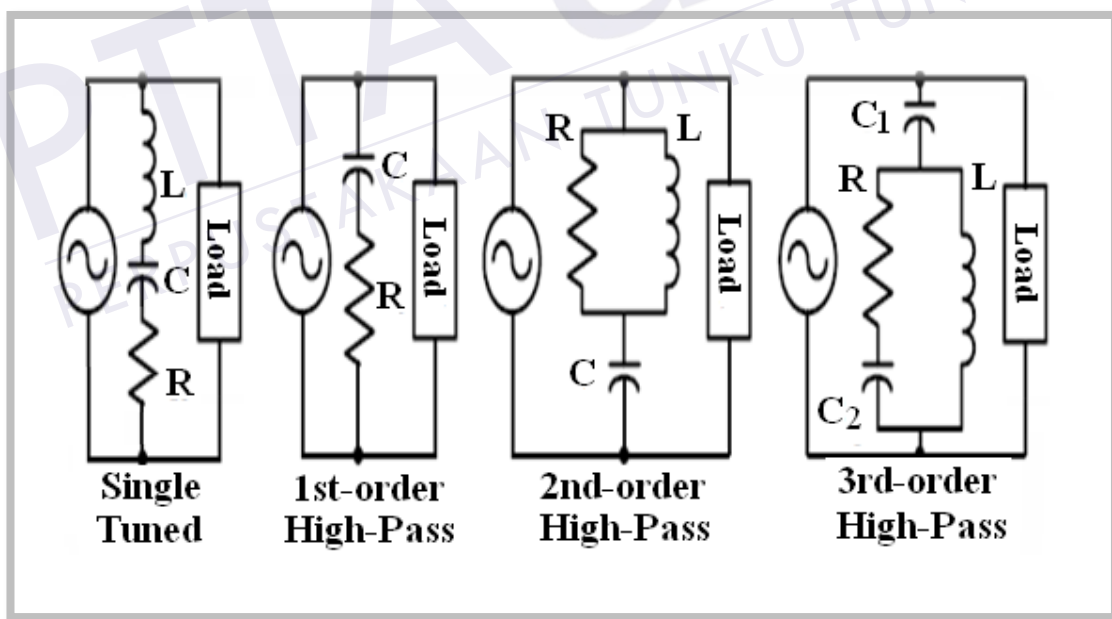

Figure 2.8: Type of Passive Filter

Table 2.5 shows comparison of different types of passive filters used for harmonic mitigation.

**Table 2.5:** Comparison of different types of passive filter

Type of passive filter	advantages	disadvantages	application	Filter impedance ( $Z_F$ )
<b>Single tuned</b>	<ul style="list-style-type: none"> <li>* Inexpensive</li> <li>* Simple</li> <li>* Has low impedance</li> </ul>	<ul style="list-style-type: none"> <li>* Cannot mitigate two harmonics at same time</li> </ul>	<ul style="list-style-type: none"> <li>* Common in industrial application</li> <li>* At the PCC</li> </ul>	$R + j\omega L + \frac{1}{j\omega C}$
<b>First order high-pass</b>	<ul style="list-style-type: none"> <li>* Can filter harmonics over a certain frequency band width</li> </ul>	<ul style="list-style-type: none"> <li>* Cause large power losses at fundamental frequency</li> </ul>	<ul style="list-style-type: none"> <li>* In system that has high harmonic component</li> </ul>	$R + \frac{1}{j\omega C}$
<b>Second order high-pass</b>	<ul style="list-style-type: none"> <li>* Decrease energy losses at fundamental frequency</li> </ul>	<ul style="list-style-type: none"> <li>* Require a quite different sizing of filter elements to mitigate harmonic compared with single tuned at same harmonic</li> </ul>	<ul style="list-style-type: none"> <li>* In high voltage application</li> </ul>	$\frac{1}{j\omega C} + \frac{1}{\left(\frac{1}{R} + \frac{1}{j\omega L}\right)}$
<b>Third order (C- type) high-pass</b>	<ul style="list-style-type: none"> <li>* Avoid parallel resonances</li> <li>* Zero losses at fundamental frequency</li> </ul>	<ul style="list-style-type: none"> <li>* complex</li> <li>* expensive</li> </ul>	<ul style="list-style-type: none"> <li>* Becoming dominant in the utility environment</li> </ul>	$\left( \frac{\left(R + \frac{1}{j\omega C_2}\right) j\omega L}{\left(R + j\omega L + \frac{1}{j\omega C_2}\right)} \right) + \frac{1}{j\omega C_1}$



#### 2.4.4 Compensation Principle of Passive Shunt Filters

This part will discuss about the compensation principle of passive shunt filters. Mainly single tuned filter are used as composite filter.

A passive shunt filter mainly consists of several LCR branches each tuned at a particular frequency. Figure 2.9 shows the equivalent circuit diagram of a passive tuned shunt filter. The compensation characteristics of a passive shunt filter is equated as [9].

$$\frac{I_S}{V_L} = \frac{Z_{sh}}{Z_L Z_S + Z_L Z_{sh} + Z_S Z_{sh}} \quad (2.10)$$

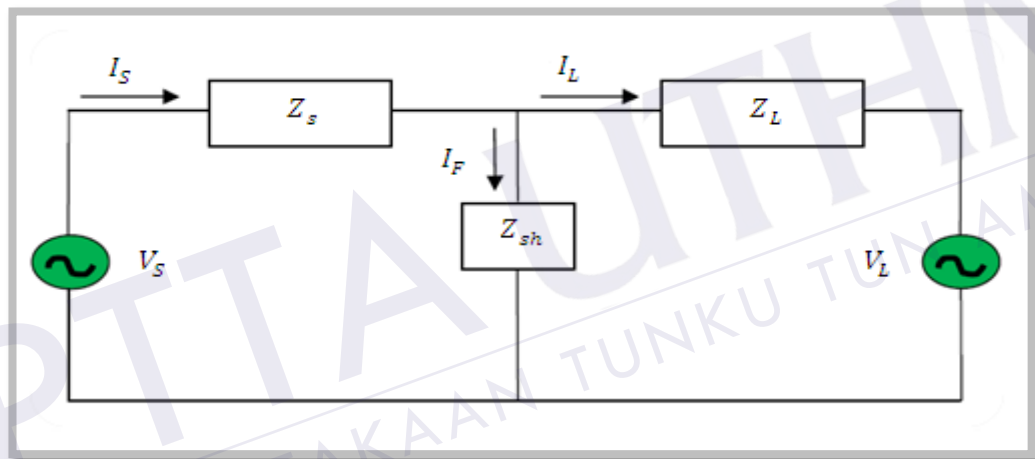

**Figure 2.9:** Equivalent circuit diagram of passive tuned shunt filter.

Where  $Z_{sh}$  is the impedance of parallel RLC filter,  $Z_L$  is the load impedance,  $Z_S$  is the line impedance,  $V_L$  is the output voltage,  $V_S$  is the input voltage,  $I_L$  is the load current,  $I_F$  is the filter current and  $I_S$  is the input current. As it can be seen from equation (2.10), that the performance of parallel RLC filter greatly depends on the source impedance .

If  $Z_L = 0$ , then from figure 2.9,  $I_S = I_L$ , which means that the passive filter is not effective. On the other hand, if  $Z_S = 0$ , then,  $\frac{I_S}{V_S} = \frac{1}{Z_L}$ , which means that the filter does not provide harmonic compensation. It is seen that the filter interaction with the line impedance results in a parallel resonance. For inductive line impedance ( $Z_S$ ), this occurs at a frequency below the frequency at which the filter is tuned. It is given as:

$$f_{sys} = \frac{1}{2\pi(L_S+L)C} \quad (2.11)$$

Moreover, if a filter is exactly tuned at a frequency of concern, then an upward shift in the tuned frequency results in a sharp increase in impedance as seen by the harmonic. The most common mechanisms that may cause filter detuning are:

- i. Capacitor fuse-blowing, which lowers the total capacitance, thereby raising the frequency at the filter has been tuned.
- ii. Manufacturing tolerances in both inductor as well as capacitor.
- iii. Temperature variations.
- iv. System parameter variations.

Therefore, generally, the filter banks are tuned to around 5% below the desired frequency as per IEEE standard 1531 [6].



## 2.5 Previous Research

The table 2.6 below shows the summary of previous research.

**Table 2.6 : Previous Research**

Sr.No	year	authors	Title	publication	Outcomes	Tools and techniques	Remark
[12]	2013	C. L. Anooja , et al	Passive Filter For Harmonic Mitigation Of Power Diode Rectifier And SCR Rectifier Fed Loads.	International Journal of Scientific & Engineering Research, Volume 4, Issue 6, June-2013 ISSN 2229-5518	Presents a comparison between diode rectifier and SCR rectifier in six pulse and twelve pulse configuration.	Matlab / Simulink	* Need to reduce the number of filters due to cost because the Author have used five filters in the test circuit. * Need to reduce firing angle in SCR rectifier because it is proportional with Total harmonic distortion.

Sr.No	year	authors	Title	publication	outcomes	Tools and techniques	Remark
[13]	2014	D.M.RAN, et al	Design of passive filters for reducing harmonic distortion and correcting power factor in two pulse rectifier systems using optimization.	Journal of Theoretical and Applied Information Technology 30th April 2014. Vol. 62 No.3 ISSN: 1992-8645 E-ISSN: 1817-3195	Presents a method capable of designing passive filters to reduce harmonic distortion and correct the power factor based on an optimization technique.	Matlab / Simulink And Genetic Algorithm	Show the result of power factor after mitigates the effect.
[14]	2010	H.Z.Azazi, et al	Review of Passive and Active Circuits for Power Factor Correction in Single Phase, Low Power AC/DC Converters.	Proceedings of the 14th International Middle East Power Systems Conference (MEPCON'10), Cairo University, Egypt, December 19-21, 2010, Paper ID 154.	Explanation about passive and active methods of power factor correction.	---	Need to show Total harmonic distortion after getting the result and the values of active and reactive power.

## REFERENCES

- 1 Grady, W. Mack, and Surya Santoso. "Understanding power system harmonics." *IEEE Power Engineering Review* 21.11 (2001): 8-11.
- 2 Fujita, Hideaki, Takahiro Yamasaki, and Hirofumi Akagi. "A hybrid active filter for damping of harmonic resonance in industrial power systems." *Power Electronics, IEEE Transactions on* 15.2 (2000): 215-222.
- 3 Lin, Whei-Min, Tung-Sheng Zhan, and Ming-Tong Tsay. "Multiple-frequency three-phase load flow for harmonic analysis." *Power Systems, IEEE Transactions on* 19.2 (2004): 897-904.
- 4 Arrillaga, Jos, & Watson, N. R. *Power system harmonics*. John Wiley & Sons, Ltd, 2004.
- 5 Dugan, Roger C., Mark F. McGranaghan, and H. Wayne Beaty. "Electrical power systems quality." *New York, NY: McGraw-Hill,| c1996* 1 (1996).
- 6 IEEE Guide for Application and Specification of Harmonic Filters., IEEE Std. 1531-2003
- 7 Das, J. C. *Power system analysis: short-circuit load flow and harmonics*. CRC press, 2011.
- 8 Duffey, and R. P. Stratford. "Update of harmonic standard IEEE-519: IEEE recommended practices and requirements for harmonic control in electric power systems." *Industry Applications, IEEE Transactions on* 25.6 (1989): 1025-1034.

- 9 Peng, Fang Z., Gui-Jia Su, and George Farquharson. "A series LC filter for harmonic compensation of ac drives." *Power Electronics Specialists Conference, 1999. PESC 99. 30th Annual IEEE*. Vol. 1. IEEE, 1999.
- 10 F II, I. "IEEE recommended practices and requirements for harmonic control in electrical power systems." (1993).
- 11 International Electrotechnical Commission. "Limits for harmonic current emissions (equipment input current  $\leq 16$  A per phase)." (2004).
- 12 Anooja, C. L., and N. Leena. "Passive Filter For Harmonic Mitigation Of Power Diode Rectifier And SCR Rectifier Fed Loads."
- 13 DISTORTION, HARMONIC. "DESIGN OF PASSIVE FILTERS FOR REDUCING HARMONIC DISTORTION AND CORRECTING POWER FACTOR IN TWO PULSE RECTIFIER SYSTEMS USING OPTIMIZATION." *Journal of Theoretical and Applied Information Technology* 62.3 (2014).
- 14 Azazi, H. Z., et al. "Review of passive and active circuits for power factor correction in single phase, low power AC-DC converters." *14th International Middle East Power system Conference (MEPCON'10), Egypt*. 2010.
- 15 Diwan, Seema P., H. P. Inamdar, and A. P. Vaidya. "Simulation Studies of Shunt Passive Harmonic Filters: Six Pulse Rectifier Load–Power Factor Improvement and Harmonic Control." *ACEEE Int. J. on Electrical and Power Engineering* 2.01 (2011): 1-6.
- 16 Srivastava, Kuldeep Kumar, Saquib Shakil, and Anand Vardhan Pandey. "Harmonics & Its Mitigation Technique by Passive Shunt Filter." *International Journal of Soft Computing and Engineering (IJSCE) ISSN: 2231-2307*.
- 17 Sandesh, Jain, Thakur Shivendra Singh, and S. P. Phulambrikar. "Improve Power Factor and Reduce the Harmonics Distortion of the System." *Research Journal of Engineering Sciences ISSN* (2012): 2278-9472.

- 18 Cho, Young-Sik, and Hanju Cha. "Single-tuned passive harmonic filter design considering variances of tuning and quality factor." *Journal of International Council on Electrical Engineering* 1.1 (2011): 7-13.
- 19 Bayindir, K. Çağatay, and Muammer Ermiş. "Understanding the modelling and analysis of a shunt active power filter using MATLAB/Simulink." *International Journal of Electrical Engineering Education* 43.3 (2006): 185-205.
- 20 Fujita, Hideaki, Takahiro Yamasaki, and Hirofumi Akagi. "A hybrid active filter for damping of harmonic resonance in industrial power systems." *Power Electronics, IEEE Transactions on* 15.2 (2000): 215-222.
- 21 Memon, Zubair Ahmed, Mohammad Aslam Uquaili, and Mukhtiar Ali Unar. "Harmonics mitigation of industrial power system using passive filters." *Mehran University Research Journal of Engineering and Technology* 31.2 (2012): 355-360.
- 22 Dastfan, Ali, Hossain Yassami, and Mohammad Reza Rafiei. "Optimum Design of Passive Harmonic Filter by Using Game Theory Concepts." *Intelligent Systems in Electrical Engineering* 4.4 (2014).
- 23 Cho, Young-Sik, and Hanju Cha. "A single-tuned passive harmonic filter design using transfer function approach for industrial process application." *International Journal of Mechatronics and Automation* 1.2 (2011): 90-96.
- 24 Buła, Dawid, and Marian Pasko. "Hybrid power filter with single tuned passive filter-dynamical properties." *Nonsinusoidal Currents and Compensation (ISNCC), 2010 International School on.* IEEE, 2010.
- 25 Singh, Bhim, Kamal Al-Haddad, and Ambrish Chandra. "A review of active filters for power quality improvement." *Industrial Electronics, IEEE Transactions on* 46.5 (1999): 960-971.