

CUTTING PERFORMANCE OF ADVANCED MULTILAYER COATED
(TiAlN/ AlCrN) IN MACHINING OF AISI D2 HARDENED STEEL

NUR AKMAL HAKIM BIN JASNI

A thesis submitted in partial
Fulfillment of the requirement for the award of the
Degree of Master of Mechanical Engineering



PTTAUTHM
PERPUSTAKAAN TUNKU TUN AMINAH

Faculty of Mechanical and Manufacturing Engineering
Universiti Tun Hussein Onn Malaysia

APRIL 2013

ABSTRACT

The hard machining of hardened steel with advanced cutting tool has several advantages over conventional method such as short cycle time, process flexibility, compatible surface roughness, higher material removal rate and less environment problems with absence of cutting fluid. However, caused severe tool wear and changes to quality and performance of product due to higher mechanical stress and heat generation. Thus, proper criteria should be adopted to keep the longer tool life and maintaining the quality of surface integrity. In this work, an experimental investigation was conducted to characterize the machinability of multilayer TiAlN/AlCrN coated carbide tools and surface integrity in end milling of AISI D2 hardened steel (58-62 HRC) on a Vertical Machining Centre (VMC). The cutting variables were cutting speed (80-120 m/min) and radial depth of cut (3-5 mm), meanwhile feed per tooth (0.05 mm) and depth of cut (0.5 mm) were kept constant. Tool life and volume of material removed decreased as cutting speed and radial depth of cut increased due to higher temperature and contact area. Built-up edge formation, groove formation, and edge chipping were the dominant tool failure modes; however, the cutting tool was subjected to adhesion and abrasive wear for the duration of testing. The highest volume of material removed and tool life were 1500 mm³ and 4.97 min which associate to cutting speed of 100 m/min and radial depth of cut of 4 mm. The surface roughness, R_a values attained throughout the experiments were in range of 0.20 to 0.45 μm which may acceptable in mould and die fabrication. The optical microscope observations show that the milled surface is anisotropic in nature. Meanwhile, the surface defects observed during machining included feed marks, grooves, microchips or debris and cavities and the existence of surface defects caused by thermal softening of the material and interaction between cutting tool and workpiece. This study showed that a thin layer of plastic deformation was formed in the immediate sub-surface of the workpiece, and the microhardness was altered to a depth of 0.28 mm beneath the machined surface due to high pressure and elevated heat. Nevertheless, all cutting tools experienced excessive coating delamination by crack and strip from the substrate due to high friction and thermal cycling generated and low toughness of the coating. It can be concluded that hard machining can be carried out for AISI D2 hardened steel with multilayer TiAlN/AlCrN coated carbide tooling because the process has been proven to produce high productivity and functional performance of quality machined parts with respect to surface integrity.

ABSTRAK

Pemesinan keras pada keluli terkeras menggunakan alat pemotong termaju mempunyai beberapa kelebihan berbanding kaedah konvensional seperti kitaran masa yang singkat, proses yang fleksibel, kekasaran permukaan yang sesuai, kadar pemotongan bahan yang tinggi dan kurang masalah persekitaran kerana tidak menggunakan cecair pemotong. Walaubagaimanapun, masalah tersebut mendorong kepada kehausan alat pemotong yang teruk dan perubahan kepada kualiti dan sifat produk disebabkan oleh penghasilan tekanan mekanikal dan kepanasan yang sangat tinggi. Oleh itu, kriteria yang betul diperlukan untuk memanjangkan jangka hayat alat pemotong dan mengekalkan kualiti integriti permukaan. Dalam kajian ini, suatu eksperimen telah dijalankan untuk mengkaji kebolehmesinan alat pemotong, karbida bersadur TiAlN/AlCrN dan integriti permukaan dalam pemesinan keluli terkeras AISI D2 (58-62 HRC) menggunakan Vertical machining centre (VMC). Antara pemboleh ubah pemotongan adalah kelajuan pemotongan (80-120 m/min) dan lebar kedalaman pemotongan (3-5 mm), manakala suapan per gigi (0.05 mm) dan kedalaman pemotongan (0.5 mm) dimalarkan. Jangka hayat alat pemotong dan isipadu bahan dipotong menurun apabila kelajuan dan lebar kedalaman pemotongan meningkat disebabkan oleh ketinggian suhu dan keluasan permukaan bersentuh. Kejadian *built-up edge*, kejadian alur dan serpihan sisi adalah kegagalan alat pemotong, sementara itu, geseran dan hakisan adalah mekanisme kegagalan sepanjang tempoh ujian. Jumlah tertinggi isipadu bahan yang dipotong dan hayat alat pemotong adalah 1500 mm³ dan 4.97 min menggunakan kelajuan pemotongan sebanyak 100 m/min dan lebar kedalaman pemotongan sebanyak 4 mm. Kekasaran permukaan dicapai sepanjang eksperimen dalam lingkungan 0.20-0.45 µm yang boleh diterima dalam penghasilan mould and die. Pemerhatian mikroskop optik menunjukkan bahawa permukaan yang telah dimesin adalah *anisotropic* secara semulajadi. Kajian ini menunjukkan bahawa satu lapisan kecacatan plastik nipis terbentuk di bawah permukaan bahan kerja, dan kekerasan mikro telah berubah sehingga 0.28 mm di bawah permukaan yang dimesin disebabkan oleh tekanan tinggi dan peningkatan suhu. Tambahan lagi, semua alat pemotong mengalami delaminasi saduran yang teruk iaitu retak dan tanggal daripada *substrate* kerana geseran yang tinggi dan peningkatan kitaran haba. Kajian ini boleh disimpulkan bahawa pemesinan keras boleh dijalankan bagi keluli terkeras AISI D2 menggunakan alat pemotong karbida bersadur TiAlN/AlCrN kerana proses tersebut telah terbukti menghasilkan ketinggian produktiviti dan kualiti bahagian yang telah dimesin berdasarkan integriti permukaan.

CONTENTS

TITLE	i
DECLARATION	ii
DEDICATION	iii
ACKNOWLEDGEMENT	iv
ABSTRACT	v
ABSTRAK	vi
CONTENTS	vii
LIST OF ABBREVIATIONS	xii
LIST OF APPENDICES	xiv
LIST OF FIGURES	xv
LIST OF TABLES	xxiii
CHAPTER 1 INTRODUCTION	1
1.1 Background of study	1
1.1.1 The benefits of high speed machining in hard machining	3
1.1.2 Multi-layer Coated Carbide as cutting tool	4
1.1.3 Machinability and surface integrity in productive machining	7
1.2 Problem statement	9
1.3 Significance of study	10
1.4 Purpose of study	11
1.5 Scope of study	11
1.6 Hypothesis	13



CHAPTER 2 FUNDAMENTAL STUDY OF MACHINABILITY AND SURFACE INTEGRITY IN METAL CUTTING 14

2.1 Tool wear performance	14
2.1.1 Tool failure mode	15
2.1.2 Tool wear mechanism	18
2.1.3 Tool life	20
2.2 Surface integrity	20
2.2.1 Surface topography	21
2.2.2 Surface metallurgy	23

CHAPTER 3 LITERATURE REVIEW 26

3.1 A review on coated carbide tool selection in machining of difficult-to-cut material	26
3.2 Tool life and tool wear performance in machining of AISI D2 hardened steels	30
3.3 Surface integrity in machining of AISI D2 hardened steels	34
3.4 Selection cutting parameter in machining of AISI D2 hardened steels using coated carbide tool	39
3.5 Summary	41

CHAPTER 4 METHODOLOGY 43

4.1 Research design principles	45
4.1.1 Higher MRR to employ higher productivity	45
4.1.2 High speed milling under dry cutting	46
4.2 Experimental design and variables	46
4.2.1 Machining parameters	47



4.2.2 Machining characteristic/output	48
4.3 Research procedures	50
4.3.1 Workpiece preparation	51
4.3.2 Cutting tool preparation	52
4.3.3 Experimental setup	56
4.4 Equipment and instrumentation	57
4.4.1 Major equipment	58
4.4.2 Measuring equipment	59
4.5 Specimen preparation for subsurface of machined workpiece analysis	66
4.5.1 Goal of specimen preparation	67
4.5.2 Sectioning	68
4.5.3 Mounting of specimen	70
4.5.4 Grinding	72
4.5.5 Polishing	73
4.5.6 Etching	75
4.6 Specimen preparation for coating analysis	77
CHAPTER 5 RESULT AND DISCUSSION	79
5.1 Machinability	79
5.1.1 Tool life and tool wear performance	80
5.1.1.1 Effect of cutting speed on tool life, tool wear performance and volume of material removed	102
5.1.1.2 Effect of radial depth of cut on tool life, tool wear performance and volume of material removed	108
5.1.2 Surface roughness of machined surface	112
5.1.2.1 Surface roughness in feed speed direction, V_f	113
5.1.3 A relationship between tool wear propagation and surface roughness	119



5.1.3.1 Summary of relationship between tool wear propagation and surface roughness	134
5.2 Surface integrity of machined workpiece	135
5.2.1 Surface topography of machined surface	135
5.2.1.1 Summary of surface topography of machined surface	141
5.2.2 Surface defects of machined surface	141
5.2.3 Subsurface deformation of machined workpiece	146
5.2.3.1 Discussion: Subsurface deformation of machined surface	158
5.2.3.2 Effect of cutting speed and radial depth of cut on subsurface of machined workpiece	160
5.2.4 Microhardness alteration of machined workpiece	162
5.3 Coating characterization	168
5.3.1 Discussion on coating characterization	174
5.4 Overview the relationship between tool wear, surface topography and subsurface of machined workpiece	176
CHAPTER 6 CONCLUSION AND CONTRIBUTION	181
6.1 Conclusion	181
6.2 Contribution of this work	185
REFERENCES	187
APPENDICES	203
Appendix A	203



Appendix B	211
Appendix C	215
Appendix D	220
Appendix E	223
Appendix F	226
Appendix G	227
RELATED PUBLICATION	236



PTTA UTHM
PERPUSTAKAAN TUNKU TUN AMINAH

LIST OF ABBREVIATIONS

EDM	Electrical discharge machining
HSM	High speed machining
PCBN	Polycrystalline cubic boron nitride
PCD	Polycrystalline diamond
TiN	Titanium Nitride
TiAlN	Titanium Aluminium Nitride
TiCN	Titanium Carbon Nitride
PVD	Physical vapour deposition
CVD	Chemical vapour deposition
AlCrN	Aluminium Chromium Nitride
CrN	Chromium Nitride
<i>MRR</i>	Material removal rates
<i>VMR</i>	Volume of material removed
V_c	Cutting speed
N	Rotational per minute
n	Number of teeth
f	Feed
f_r	Feed rate
a_p	Axial depth of cut
a_e	Radial depth of cut
TL	Tool life
R_a	Average surface roughness
<i>LOC</i>	Length of cut
BUE	Built-up edge
VB	Flank wear
KT	Crater wear
3D	Three dimension

AMZ	Altered material zone
TiAlSiN	Titanium Aluminium Silicon Nitride
HRC	Hardness Rockwell C
TiAlCrN	Titanium Aluminium Chromium Nitride
SEM	Scanning electron microscope
FeSEM	Field emission scanning electron microscope
AFM	Atomic force microscope
HV	Hardness Vickers Pyramid Number
VMC	Vertical machining centre
EDS	Energy dispersive X-Ray spectrometer



PTTA UTHM
PERPUSTAKAAN TUNKU TUN AMINAH

LIST OF APPENDICES

A	Coated carbide tool characteristic in machining of difficult-to-cut materials	204
B	Review on tool wear and tool life performances in machining of AISI D2 hardened steels	211
C	Review on surface integrity in machining of AISI D2 hardened steels	215
D	Selection parameter in machining of AISI D2 using coated carbide tool	220
E	Cutting parameter calculation	223
F	Actual parameter and surface roughness	226
G	Coating characterization	241



PTTA UTHM
PERPUSTAKAAN TUN AMINAH

LIST OF FIGURES

1.1	The main benefits to be gained from adopting a high-speed machining (HSM) strategy	4
1.2	The role of coatings in the alteration of cutting performance	5
1.3	Tribologically important properties in different zones of the coated surface (Holmberg and Matthews, 2009)	6
1.4	Problems in hard machining	9
2.1	Types of tool wear according to standard ISO 3685: 1993 (Davim, 2008)	18
2.2	Evolution of the flank wear land VB_B as a function of cutting time for different cutting speeds (Abburi & Dixit, 2006)	19
2.3	The six groups of key factors that define the surface integrity of a finished material (ASM, 1994)	21
2.4	3D surface of machined workpiece	22
2.5	Schematic section through a machined surface (Griffiths, 2001)	24
2.6	FeSEM image of subsurface of machined workpiece	25
4.1	Overall Methodology Research	44
4.2	Specimen test preparation	47
4.3	Two categories of machining characteristic	48
4.4	Experimental process flow chart	50
4.5	EDX analysis of AISI D2 hardened steel	51



4.6	Hardness testing on AISI D2 hardened steel	52
4.7	Characteristics of film	54
4.8	Cross sectional TEM Photo of coating	54
4.9	TiAlN/AlCrN cutting tool	55
4.10	Dimension of TiAlN/AlCrN cutting tool	55
4.11	Dimensions of tool holder	56
4.12	Experimental setup	57
4.13	Vertical Machining Centers Nexus 410A-II	58
4.14	Tool maker microscope Nikon MM-60	60
4.15	Mahr Perthometer PGK-120	61
4.16	Scanning electron microscope (Joel-JSM 6380 L.V)	62
4.17	Vickers hardness tester	63
4.18	Subsurface region of machined workpiece	64
4.19	Microhardness measurement beneath the machined surface	64
4.20	Analytical field emission scanning electron microscope (FE-SEM) JSM-7500F	65
4.21	Park Systems XE-100 Atomic Force Microscope (AFM)	66
4.22	Specimen preparation for subsurface of machined workpiece analysis	68
4.23	Machined workpiece	69
4.24	Sample after cutting process at point A	70
4.25	Abrasive cut-off machine (Stuers Lobotom 3)	70
4.26	Specimens after compression mounting	71
4.27	Buehler Auto Mounting Press machine	72
4.28	Buehler Roll Grinder	73
4.29	Polish machine	75
4.30	Etching process flowchart	76
4.31	(a) Bright and (b) dark field illumination	76
4.32	Cutting tool tip	77



4.33	Specimen preparation for subsurface of coating analysis	78
5.1	SEM image of fresh TiAlN/AlCrN cutting tool on rake and flank face	81
5.2	EDX analysis of rake and flank face of fresh TiAlN/AlCrN cutting tool	82
5.3	Tool life and volume of material removed	83
5.4	Tool wear propagation for each trial	84
5.5	Tool wear propagation for Trial-1 [$V_c = 120$ m/min and $a_e = 5$ mm]	85
5.6	Different magnification versus tool wear morphology views for Trial-1 [$V_c = 120$ m/min and $a_e = 5$ mm]	86
5.7	Tool wear propagation for Trial-2 [$V_c = 100$ m/min and $a_e = 5$ mm]	87
5.8	Different magnification versus tool wear morphology views for Trial-2 [$V_c = 100$ m/min and $a_e = 5$ mm]	88
5.9	Tool wear propagation for Trial-3 [$V_c = 80$ m/min and $a_e = 5$ mm]	89
5.10	Different magnification versus tool wear morphology views for of Trial-3 [$V_c = 80$ m/min and $a_e = 5$ mm]	90
5.11	Tool wear propagation for Trial-4 [$V_c = 120$ m/min and $a_e = 4$ mm]	91
5.12	Different magnification versus tool wear morphology views for Trial-4 [$V_c = 120$ m/min and $a_e = 5$ mm]	92
5.13	Tool wear propagation for Trial-5 [$V_c = 100$ m/min and $a_e = 4$ mm]	93
5.14	Different magnification versus tool wear morphology views for Trial-5 [$V_c = 100$ m/min and $a_e = 4$ mm]	94



PTTA UTHM
PERPUSTAKAAN TEKNIK TUN AMINAH

5.15	Tool wear propagation for Trial-6 [$V_c = 80$ m/min and $a_e = 4$ mm]	95
5.16	Different magnification versus tool wear morphology views for Trial-6 [$V_c = 80$ m/min and $a_e = 4$ mm]	96
5.17	Tool wear propagation for Trial-7 [$V_c = 120$ m/min and $a_e = 3$ mm]	97
5.18	Different magnification versus tool wear morphology views for Trial-7 [$V_c = 120$ m/min and $a_e = 3$ mm]	98
5.19	Tool wear propagation for Trial-8 [$V_c = 100$ m/min and $a_e = 3$ mm]	99
5.20	Different magnification versus tool wear morphology views for Trial-8 [$V_c = 100$ m/min and $a_e = 3$ mm]	100
5.21	Tool wear propagation for Trial-9 [$V_c = 80$ m/min and $a_e = 3$ mm]	101
5.22	Different magnification versus tool wear morphology views for Trial-9 [$V_c = 80$ m/min and $a_e = 3$ mm]	102
5.23	Wear on the rake and flank faces of the tool for various cutting speeds	104
5.24	EDX analysis of a worn cutting tool each tested cutting speed	106
5.25	Presence of groove on flank faces at (a) $V_c = 100$ m/min and (b) $V_c = 120$ m/min with a_e of 5 mm	107
5.26	Wear on the rake and flank faces of the tool for various radial depths of cut	109
5.27	Presence of groove on flank faces at $V_c = 120$ m/min with (a) a_e of 4 mm and (b) $a_e = 5$ mm	110
5.28	EDX analysis of a worn cutting tool for each tested radial depth of cut	111



5.29	Schematic of surface roughness measuring point	112
5.30	The effect of cutting speed and radial depth of cut on surface topography	113
5.31	The effect of cutting speed on surface roughness in feed direction	115
5.32	The effect of radial depth of cut on surface roughness in feed direction	117
5.33	Tool wear propagation and surface roughness of $V_c = 80$ m/min and $a_e = 3$ mm	120
5.34	SEM image of surface topography on machined surface at <i>LOC</i> of 850 mm	121
5.35	Tool wear propagation and surface roughness of $V_c = 100$ m/min and $a_e = 3$ mm	122
5.36	SEM image of surface topography on machined surface at <i>LOC</i> of 500 mm	123
5.37	Tool wear propagation and surface roughness of $V_c = 120$ m/min and $a_e = 3$ mm	124
5.38	SEM image of surface topography on machined surface at <i>LOC</i> of 700 mm	125
5.39	Tool wear propagation and surface roughness of $V_c = 80$ m/min and $a_e = 4$ mm	126
5.40	Surface topography of machined workpiece at length of cut of 500 mm	127
5.41	Tool wear propagation and surface roughness of $V_c = 100$ m/min and $a_e = 4$ mm	128
5.42	Tool wear propagation and surface roughness of $V_c = 120$ m/min and $a_e = 4$ mm	129
5.43	Tool wear propagation and surface roughness of $V_c = 80$ m/min and $a_e = 5$ mm	130
5.44	Tool wear propagation and surface roughness of $V_c = 100$ m/min and $a_e = 5$ mm	132
5.45	Surface topography of machined workpiece at length of cut of 250 mm	133



5.46	Tool wear propagation and surface roughness of $V_c = 120$ m/min and $a_e = 5$ mm	134
5.47	Optical microscope images of machined surface condition under different cutting parameters	136
5.48	AFM image of Trial-1 ($V_c = 120$ m/min, $a_e = 5$ mm)	138
5.49	AFM image of Trial-5 ($V_c = 100$ m/min, $a_e = 4$ mm)	139
5.50	AFM image of Trial-8 ($V_c = 100$ m/min, $a_e = 3$ mm)	140
5.51	AFM image of Trial-9 ($V_c = 80$ m/min, $a_e = 3$ mm)	141
5.52	SEM images of machined surface under different cutting parameters	143
5.53	EDX analysis on debris at the machined surface	144
5.54	Presence of cavities on machined surface in high magnification	145
5.55	FeSEM image of original subsurface of AISI D2	147
5.56	FeSEM image of original subsurface in higher magnification scale	148
5.57	EDX analysis on carbide particle	148
5.58	FeSEM image of grain, grain boundary and porosity of AISI D2	149
5.59	FeSEM image of the subsurface layer for Trial-1 ($V_c = 120$ m/min and $a_e = 5$ mm)	150
5.60	FeSEM image of the subsurface layer for Trial-2 ($V_c = 100$ m/min and $a_e = 5$ mm)	151
5.61	FeSEM image of the subsurface layer for Trial-3 ($V_c = 80$ m/min and $a_e = 5$ mm)	152
5.62	FeSEM image of the subsurface layer for Trial-4 ($V_c = 120$ m/min and $a_e = 4$ mm)	153
5.63	FeSEM image of the subsurface layer for Trial-5 ($V_c = 100$ m/min and $a_e = 4$ mm)	154



5.64	FeSEM image of the subsurface layer for Trial-6 ($V_c = 80$ m/min and $a_e = 4$ mm)	155
5.65	FeSEM image of the subsurface layer for Trial-7 ($V_c = 120$ m/min and $a_e = 3$ mm)	156
5.66	FeSEM image of the subsurface layer for Trial-8 ($V_c = 100$ m/min and $a_e = 3$ mm)	157
5.67	FeSEM image of the subsurface layer for Trial-9 ($V_c = 120$ m/min and $a_e = 3$ mm)	158
5.68	FeSEM images of subsurface with increasing cutting speed	161
5.69	FeSEM images of subsurface with increasing radial depth of cut	162
5.70	Effect of cutting speed on the variation of microhardness with depth below the machined surface at $a_e = 5$ mm	163
5.71	Effect of radial depth of cut on the variation of microhardness with depth below the machined surface at $V_c = 80$ m/min	166
5.72	Detailed FeSEM images of the interface between the TiAlN/AlCrN coating and the substrate	169
5.73	EDX analysis of the cutting tool coating and substrate	170
5.74	X-ray phase analysis of TiAlN/AlCrN coating deposited on WC-Co substrate	171
5.75	Representative cross-sectional FeSEM image of fresh tool	172
5.76	Cross-sectional FeSEM image of worn tool ($V_c =$ 80 m/min and $a_e = 3$ mm)	173
5.77	Relationship of tool wear and coating	174
5.78	Flank wear profile of different cutting speed (80, 100 and 120 m/min) at radial of cut of 5 mm	175



5.79	Relationship between tool wear, surface topography and subsurface of machined workpiece at $V_c = 80$ m/min and $a_e = 3$ mm	178
5.80	Relationship between tool wear, surface topography and subsurface of machined workpiece at $V_c = 100$ m/min and $a_e = 4$ mm	179
5.81	Relationship between tool wear, surface topography and subsurface of machined workpiece at $V_c = 120$ m/min and $a_e = 5$ mm	180



PTTA UTHM
PERPUSTAKAAN TUNKU TUN AMINAH

LIST OF TABLES

2.1	Tool failure mode and cause	15
4.1	Machining parameter	48
4.2	Tabulated table	49
4.3	Chemical composition of AISI D2 hardened steel	51
4.4	Physical properties of AISI D2 hardened steel	52
4.5	Element properties of TiAlN/AlCrN coating	53
4.6	Dimension of tool holder	56
5.1	Actual parameter and responses	83
6.1	Relationship of tool life and economy context	183



PTTA UTHM
PERPUSTAKAAN TUNKU TUN AMINAH

CHAPTER 1

INTRODUCTION

1.1 Background of study

Hard machining of hardened steels is an alternative to grinding and electrical discharge machining (EDM) which is mostly accepted as traditional methods of machining materials with hardness greater than 50 HRC. Its competitiveness over grinding and EDM processes for industrial applications is still limited despite its potential for high productivity and environmental-friendly dry machining process. However, the benefits of hard machining are reduced machining costs and lead times in comparison to current traditional route, which involves processes such as annealing, heat treatment, grinding, electrical discharge machining and polishing. Hard machining technology was first applied in mould and die making industries other than the aerospace sector by empowering robust machine tools with the application of advanced cutting tools and its coatings. Moulds, forging and die casting dies are potential applications of hard machining process. Higher cutting parameters (i.e. higher cutting speed and radial depth of cut) are employed for rough machining in order to have more material removal rate using solid carbide and indexable inserts. This process has become normal practice in industry because of increased productivity and reduced energy consumption (Fnides et al., 2008; Fnides et al., 2009; Bouacha et al., 2010).

The difficult-to-cut materials (i.e. AISI D2 hardened steel) with high strength, toughness and hardness, such as hardened steel, have wide applications

in the moulds and dies industry (Chen et al., 2007). During the last few years numerous studies have been conducted to improve the machinability of this kind of materials and to explore and develop new techniques to minimize machining costs while maintaining the quality requirements of the machined parts. The benefits of direct manufacture of components from hardened steel (i.e. AISI D2) are expected to be substantial especially in the context of machining costs and lead times compared to the traditional route of machining in the annealed state followed by heat treatment, grinding or electrical discharge machining (EDM), and manual finishing. But despite the extensive use and potential scope of AISI group D tool steel for cold-forming operations, most information about the machinability of AISI D2 hardened steel is highly needed (Koshy et al., 2002). Nevertheless, a large proportion of the literature relating to hardened steel refers to AISI H13 hot work tool steel, which is used in the manufacture of moulds and dies including hot-forming dies.

In hard machining processes, polycrystalline cubic boron nitride (PCBN) tools have become a common choice for cutting tools in the industry. PCBN clearly exhibits high cutting performance in terms of tool wear and workpiece surface roughness. Because PCBN tools are very expensive, a coated carbide tool, which was 4-5 times cheaper than a PCBN tool, was chosen for this study. Typically, a PCBN tip is brazed onto an insert so only one edge can be used; however, for a coated carbide tool, it is possible to use all the edges. Carbide tools have high toughness but poor wear characteristics compared to advanced tool materials, such as PCBN and ceramics. To improve hardness and surface integrity, carbide tools are coated with harder materials, such as TiN, TiAlN, and TiCN (Camuscu & Aslan, 2005). Coatings improve wear resistance, increase tool life and enable higher cutting speeds to be used. Improved wear resistance results from the superior coating hardness, chemical inertness and reduced coefficient of friction (Liew, 2010; Ding et al., 2011). Therefore, there is a keen interest in the utilisation of coated carbide tools that can mostly replace expensive cutting tools (i.e., PCBN and ceramic), particularly in high productivity hard machining processes. Recent advances in machine tool technologies coupled with improved cutting tool inserts have opened up new opportunities for investigation in machining of hard materials especially for their cutting performance.



1.1.1 The benefits of High Speed Machining in hard machining

A very important indicator of the performance of metal cutting operations is the productivity or volume of material removed per unit time. No matter how long a cutting tool can last if the volume material rate is small (Abou-El-Hossein and Yahya, 2005). The productivity of machining operations can be expanded and the quality of products can be improved by using higher material removal rate (i.e. higher cutting speed and radial depth of cut) than applies traditionally. Otherwise, HSM has been incorporated to accelerate the spindle speed without necessary used of coolant/ lubricant.

Furthermore, high speed machining (HSM) has been of special interest to both manufacturing and academia sectors for many years. In the last decade, there have been many significant developments in high speed machining relative to machining controls and tooling. These advances in cutting technology are helping manufacturing companies reduce their production costs, shorten delivery times, manufacture complex, high quality parts and accelerate product development cycles (Grzesik, 2008). High speed machining is also recognized as a manufacturing technology of higher productivity and throughput, and is thus creating considerable interest for die and mould manufacture.

Several studies have been performed to investigate the feasibility of HSM of dies and molds in their hardened state. Machining at low cutting speeds (<80 m/min) generates less heat at the cutting edge and thus prolongs tool life (Kim et al., 2001; Iqbal et al., 2007; Lajis et al., 2008; Kang et al., 2008; Jeong et al., 2009). However, few researchers have tried to optimise the productivity of hard machining of hardened steel by increasing the material removal rate (i.e., using higher cutting speeds); therefore, the maximum cutting speed that can be used without significantly reducing tool life is still scarce. Additionally, there has been little work on variations in radial depth of cut in hard machining, so the investigation of this subject is highly necessary. Figure 1.1 illustrates the main benefit to be gained from adapting a high-speed machining. As a result of advances in cutting tool and machine tool technologies, machining is being performed at ever increasing cutting speed and radial depth of cut.

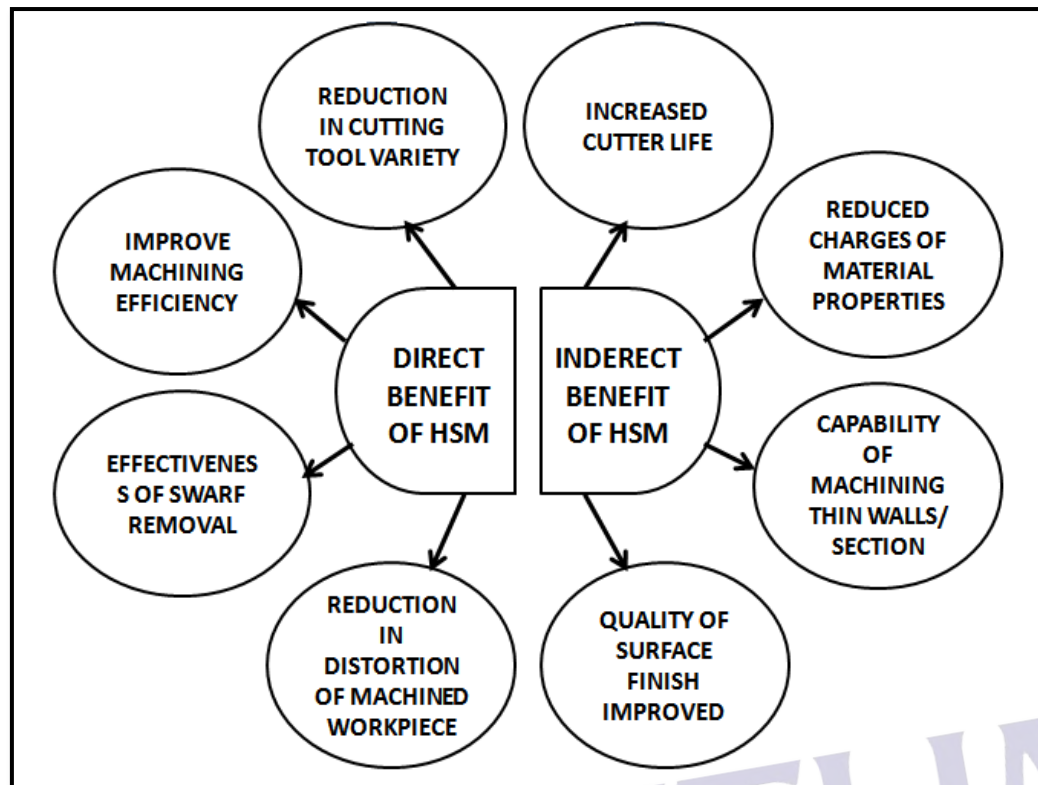

Figure 1.1: The main benefits to be gained from adopting a high-speed machining (HSM) strategy (Smith, 2008)

1.1.2 Multi-layer Coated Carbide as a cutting tool

Carbide tool is the most common tool material for machining castings and alloy steels. It has high toughness, but poor wear characteristics compared to advanced tool materials such as PCBN and ceramics. In order to improve the hardness and surface integrity, carbide tools are coated with hard materials such as TiN, TiAlN, and TiCN by physical vapour deposition (PVD) and chemical vapour deposition (CVD) (Aslan, 2005). The process selected whether PVD or CVD depends on the tool material composition, tool geometry and application (Boothroyd & Knight, 2006). However, this study focuses only on the PVD process according to the scope of study. Moreover, Koshy et al. (2002) suggested that, for tool steel D2, it is better to employ indexable insert cutters rather than their solid carbide, considering that the latter are typically 5–8 times more expensive. The tools play an important role in the total costs of machining.

Since the introduction of PVD coatings on machining tools almost thirty years ago, many new hard coatings have been developed in order to increase the machining speed, the lifetime of the coated tools and to improve the quality of the machined surface. The reason for such rapid development of coating technology and growing popularity of coated tools in the metal-cutting industry is that the coatings can positively alter the cutting process performance as illustrated in Figure 1.2. Figure 1.2 shows the role of coating in alteration of cutting performance.

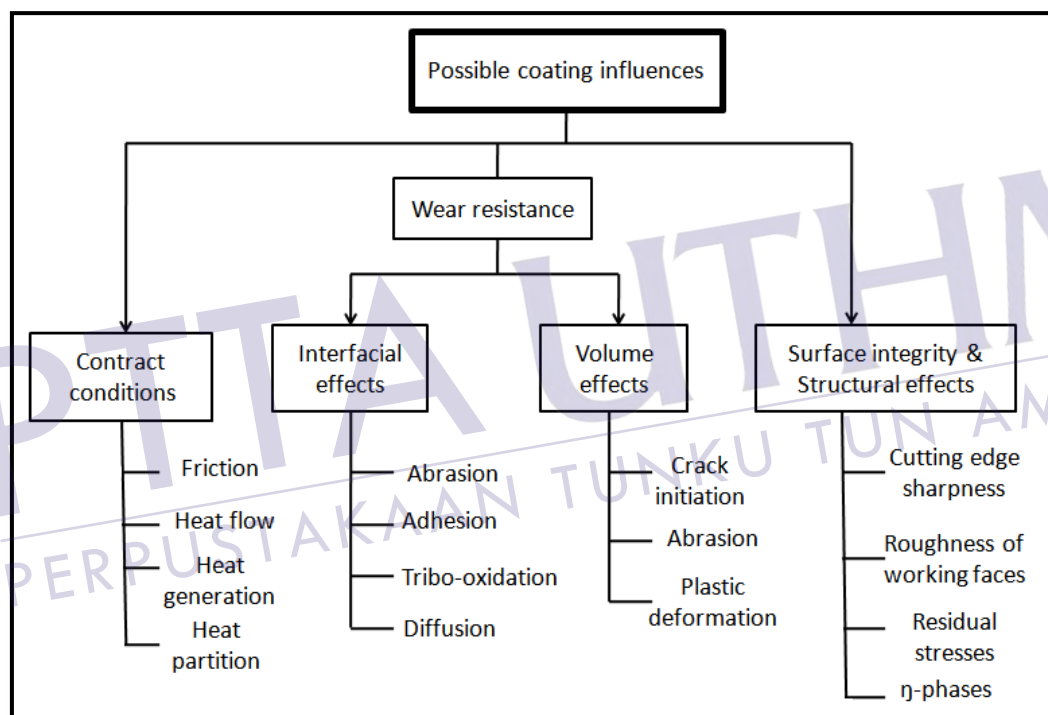

Figure 1.2: The role of coatings in the alteration of cutting performance (Grzesik, 2008)

A hard layer on a softer substrate will give improved protection against scratching from a hard counter face or debris. Hard coatings have thus been especially useful in application involving abrasive or erosive wear. An early successful application was ceramic coatings, especially aluminium oxide, titanium nitride and titanium carbide, on cutting tools where they give good protection against a combination of diffusion and abrasive wear at high temperatures. This

has often resulted in extensions of tool lifetimes by ten times or more (Holmberg and Matthews, 2009). Figure 1.3 distinguishes between four different zones, each with different properties which must be considered.

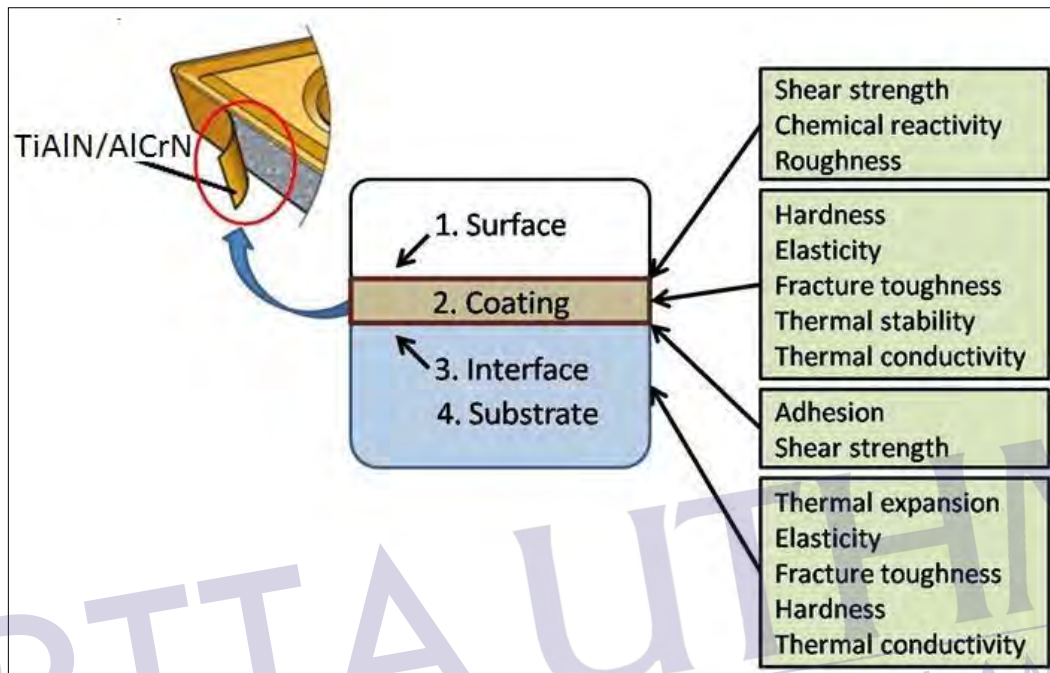

Figure 1.3: Tribologically important properties in different zones of the coated surface (Holmberg and Matthews, 2009)

Recently, a new class of multilayer TiAlN/AlCrN coatings with added chromium has been subject to increasing interest due to their excellent properties, particularly under high temperature conditions. Okada et al. (2011) carried out an extensive study that showed promising results in oxidation tests and cutting tool applications for a TiAlN/AlCrN coating. However, the available data on the cutting performance of these coatings are still very limited. Liew (2010) found that tribo-oxidation plays an important role in the wear properties of TiAlN/AlCrN coatings. Coating characteristics are more important once a coating has been optimised and is in production, while the friction and wear performance and composition are usually of greater interest when a tribological coating is under development. Thus the evaluation of coating characteristics is vital.

1.1.3 Machinability and surface integrity in productive machining

Numerous investigations have been carried out to improve the machinability (tool life, tool wear performance, surface roughness and etc.) and surface integrity (surface topography and metallurgy) of AISI D2 hardened steels, most of these are based on turning operation. However the results obtained through the turning operation are not likely to represent features of the milling operation in which interruption occurs in machining work unlike the situation in turning where a continuous cutting takes place. In machining process, the tool may experience repeated contact loads during interrupted cuts, and the workpiece may chemically interact with the tool material. The response of a tool material to the above tribological condition dictates its performance. Moreover, the damages of a cutting tool are influenced by the stress state and temperature at the tool surfaces, the cutting conditions and the presence or not of cutting fluid and its type. In machining, the tool damage mode and the rate of damage are very sensitive to changes in the cutting operation and the cutting conditions. To minimize machining cost, it is not only to find the best cutting tool in terms of cutting performance and cost and work combination for a given machining operation, but also to reliably predict the tool life (Grzesik, 2008).

Furthermore the quality and performance of a product is directly related to surface integrity achieved by final machining (Ulutan & Ozel, 2011). Manufacturing processes such as hard machining causes changes to the microstructure and consequently to the mechanical properties and quality of the surface (Umbrello & Filice, 2009). Otherwise, the choice of manufacturing processes is based on cost, time and precision. Precision of a surface is one of the topographical features which divided by two criteria: dimensional accuracy and surface finish. Nevertheless, another criterion has become increasingly important is the performance of the surface (Davim, 2008).

Besides, the main interest in this study is to obtain high productivity in machining of AISI D2 using coated carbide tool. With the rapidly growing trends in developing and deploying advanced processing technologies, manufactured components/products are expected to demonstrate superior quality and enhanced functional performance. Material removal processes continue to dominate among

all manufacturing processes. The functional performance of components from material removal processes is heavily influenced by the quality and reliability of the surfaces produced both in terms of topography as well as metallurgical and mechanical state of the subsurface layers (Jawahir et al., 2011).

The importance of material removal operations in the scheme of things may be realized by considering the total cost associated with this activity, including expendable tool cost, workpiece cost and etc. There are several reasons for developing a rational approach to material removal (Shaw, 2005):

1. To improve cutting techniques-even minor improvements in productivity are of major importance in high volume production.
2. To produce products of greater precision and of greater useful life.
3. To increase the rate production and produce a greater number and variety of products with the tools available.

Increasing material removal rate (*MRR*) (i.e. increasing cutting speed, V_c and radial depth of cut, a_e) leads to higher productivity, however, it influences the tool wear deterioration rapidly, hence, reduces the tool life as shown in Figure 1.4. The progress of tool wear affects to the surface integrity on the workpiece as well. Therefore, it is a vital to study the relationship of tool wear performance and surface integrity to lead an optimum parameter in order to have high material removed, maximum tool life as well as acceptable surface integrity. The machinability of this group of hardened steels (group D) under various machining conditions and the corresponding tool performance (i.e. tool life, tool wear) and work-piece surface integrity (i.e. surface roughness, etc.) are worth to be investigated (Aslan, 2005).



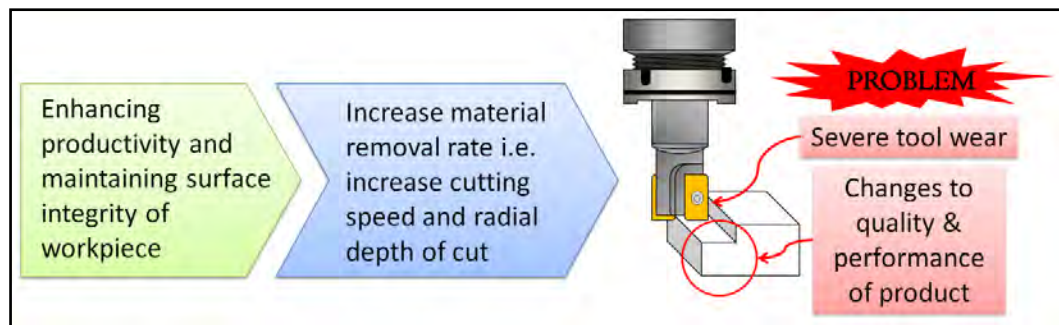

Figure 1.4: Problems in hard machining

1.2 Problem statement

In any productive machining, each process tends to remove materials as much as possible while maximizing the tool life hence keeps maintain the quality of functional performance (i.e. surface integrity). Enhancing the productivity in machining operation most associated with increasing the material removal rate (*MRR*) by employing the higher values of cutting speed, feed, axial and radial depth of cut. However, in machining hard materials i.e. AISI D2 hardened steels with incorporating the high speed operation, the cutting tools wear very much due to the mechanical stress and temperature increases. It has been understood that, the acceptable quality of surface integrity depends on the initial considered portion of the tool wear progression, and consequently it depends on the final shape of the cutting tools. Additionally, experimentations revealed that the preferable surface integrity would be obtained if the proper setting of cutting parameter as well as a small wear was prudently monitored to avoid the advent of bad or damaged zone on the workpiece. Thus, in order to realize the full potential of the higher *MRR* approach, it is indispensable to develop the relationship of machinability (i.e. tool life, tool wear performance and surface roughness) and surface integrity (i.e. surface topography and metallurgy) particularly in machining difficult-to-cut materials for which in this study AISI D2 hardened steel is the targeted materials.

In machining hardened steel, polycrystalline cubic boron nitride (PCBN) tool has become the common cutting tool because of its great cutting performance

and also excellent tool properties (i.e. higher wear resistance and hardness). However, due to the high cost and expensive which averages is about 4-5 times higher than coated carbide tools and therefore, there is a keen interest of utilizing multilayer coating of carbide cutting tools (i.e. TiAlN/AlCrN, TiAlN, etc.) which most possibly can replace the expensive cutting tools (i.e. PCBN, Cermets) particularly in high productivity of the hard machining process. Furthermore, the coating characteristics become key property once a coating has been optimized and is in production, whereas the coating thickness and deformation are usually of most interest when tribological coating is under development, thus, the evaluation of coating characteristics are highly needed in order to investigate coating characteristic in hard machining.

1.3 Significance of study

The investigation on relationship between tool wear performance (i.e. tool life, tool failure mode, tool wear mechanism, tool wear morphology and coating characteristic) and surface integrity (i.e. surface roughness, surface topography, surface defect, microstructure and microhardness) in machining of AISI D2 hardened steel using coated carbide tool leads the development of optimum range of cutting parameters which promoting maximum productivity, maximum tool life and acceptable surface integrity of workpiece. Yet, a good understanding of the relationship between tool wear performance and surface integrity can be used as the basis of future developments of tooling and workpiece respectively. Finally, the potential cutting performances of coated carbide tool in machining of AISI D2 hardened steel could be revealed and promoting to replace expensive cutting tools i.e. PCBN which is about 4-5 times higher than coated carbide.

1.4 Purpose of study

The project was undertaken to study the relationship of machinability and surface integrity in machining of AISI D2 hardened steels by using multilayer coated carbide tool (TiAlN/AlCrN) inserts with the following specific objectives:

- i) To investigate the effect of cutting variables on the following machinability criteria:
 - a) Tool wear performance (i.e. Tool life, volume of material removed, tool failure mode, tool wear mechanism and tool morphology of the cutting tools).

- ii) To identify the effect of cutting variables on the following machining characteristics and surface integrity (SI) such as:
 - a) Surface roughness of machined workpiece.
 - b) Surface topography of machined workpiece (i.e. surface morphology, 3D analysis and surface defect).
 - c) Surface metallurgy of machined workpiece (i.e. microstructure and plastic deformation).
 - d) Subsurface microhardness of machined workpiece.

- iii) To evaluate the coating characteristic (i.e. coating thickness and deformation) of multilayer coated carbide tool (TiAlN/AlCrN).

1.5 Scope of study

In order to realize the objectives of the study to be successful and reasonably implemented, the following scope of works have been derived:

- i) The higher *MRR* approach to be used in this study by employing higher of cutting speed, V_c (>80 m/min), feed, f (>0.05 mm/tooth), axial, a_p (0.5 mm) and radial depth of cut, a_e (>3 mm).
- ii) Using a high speed CNC Vertical Milling (Mazak Tech) to carry out the overall machining experiments.
- iii) Coated carbide inserts with multilayer coating (TiAlN/AlCrN) produced by Sumitomo Electric is selected as the cutting tools to machine the workpiece.
- iv) Conducting the machining operation on AISI D2 hardened steel (having a typical hardness range of (58-62 HRC) as workpiece material.
- v) The experiment is carried out under dry cutting condition.
- vi) Conducting experimental trials to investigate and evaluate the following responses;
 - a) Tool life and tool wear morphology with measurement of progressive tool wear using tool maker microscope (Nikon MM-60).
 - b) Tool failure mode and tool wear mechanism using scanning electron microscope (SEM) (JEOL-JSM 6380 L.V).
 - c) Coating characteristic analysis of TiAlN/AlCrN coated carbide using analytical field emission scanning electron microscope (FeSEM) (JSM-7500F).
 - d) Surface roughness and defect on machined surface measured using surface roughness tester (Mahr Perthometer PGK-120).
 - e) Surface morphology on machined surface and cutting tool measured using tool maker microscope (Nikon MM-60)
 - f) Three dimensional of machined workpiece analyzed by atomic force microscope (AFM) (Park Systems XE-100).
 - g) Subsurface beneath the machined surface using analytical field emission scanning electron microscope (FeSEM) (JSM-7500F).



PTTA UTHM
PERPUSTAKAAN TEKNIK DAN INDUSTRI

- h) Microhardness at beneath the machined surface measured using vickers hardness tester (Shimadzu HV-1000)

1.6 Hypothesis

Based on the investigation on relationship between machinability and surface integrity due to variable cutting parameters in machining of AISI D2 will lead to an optimum cutting parameter, which guarantees a high productivity, high tool life and acceptable surface integrity as well. The study will open up the scope of using relatively cheap coated carbide cutting tools (i.e. TiAlN/ AlCrN) instead of using PCBN or other expensive cutting tools that could be highly attractive in the context of economy in machining hardened steel and alloys. A partial of machining database developed is likely to benefit the machining practitioners and industries as it would help them in selecting optimum values of the cutting parameters. An optimal selection of cutting parameters to satisfy an economic objective which are maximizing production rate and minimum production cost.

In addition, the improvement of tool life and surface finish of the machined surfaces with the application of high material removal rate is expected to lower the cost of mould and die production. Furthermore, due to the capability of the high speed machining technique to improve surface finish, it could be a possible scope to implement single operation in certain fabrication processes, particularly in mould and die making which would eliminate the requirement of grinding and other finishing operations. Finally, a new understanding of machining hardened steel and coating characteristic analysis are expected to be established.

CHAPTER 2

FUNDAMENTAL STUDY OF MACHINABILITY AND SURFACE INTEGRITY IN METAL CUTTING

This chapter explains briefly on the tool wear and surface integrity in metal cutting process. Special attention is directed toward the tool wear performance, coated carbide tool and surface integrity such as surface topography and metallurgy. Thus, the aim is to illustrate the fundamental concepts that would be used to explain the results of this study. The sources of this chapter are from books and journals which can be divided into three subchapters. The first subchapter discusses about the fundamental of tool wear followed by the fundamental of coated carbide tool and followed by surface integrity.

2.1 Tool wear performance

Wear is usually undesirable and to be minimized. This is certainly the case with tool wear or when machine surfaces rub together and a loss material from one or both surfaces results in a change in the desired geometry of the system (Shaw, 2005). Wear on the flank of cutting tool is caused by friction between the newly machined workpiece surface and the contact area on the tool flank. Because of the rigidity of workpiece, the worn area, referred to as the flank wear land, must be parallel to the resultant cutting direction. The width of the wear land is usually taken as a measure of the amount of wear and can be readily determined by means



of toolmaker's microscope (Boothroyd & Knight, 2006). Tool wear leads to tool failure. The failure of cutting tool occurs as premature tool failure (i.e., tool breakage) and progressive tool wear. Generally, wear of cutting tools depends on tool material and geometry, workpiece materials, cutting parameters (cutting speed, feed rate and depth of cut), cutting fluids and machine tool characteristics (Davim, 2008).

2.1.1 Tool failure mode

Normally, tool wear is a gradual process. There are lot types of tool wear such as crater wear, flank wear, crater wear, notch wear, nose wear thermal cracks, chipping and plastic deformation. Figure 2.1 illustrates some types of failures and wears on cutting tools.

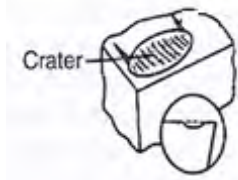
Table 2.1: Tool failure mode and cause (Grzesik, 2008)

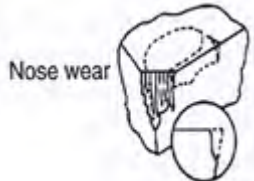
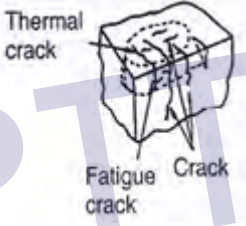
Failure	Cause
Flank wear 	Flank wear is observed on the flank or clearance flank as a result of abrasion by the hard constituents of the workpiece material. This failure mechanism is commonly observed during machining of steels.
Crater wear 	Crater wear observed on the rake face of cutting tools. It is primarily caused by chemical interaction between the rake face of a tool insert and the hot chip. Many thermally activated phenomena such as adhesion, diffusion or dissolution may be involved in the wear process.

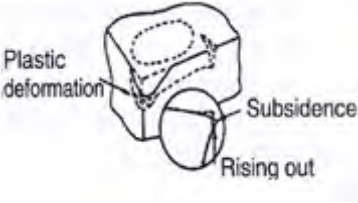
<p>Notch wear</p> 	<p>Notch wear is often attributed to the oxidation of the tool material from the sides of major and minor cutting edges, or to abrasion by the hard, saw-tooth outer edge of the chip. The workpiece materials tend to have high work-hardening and generate high tool-tip temperatures.</p>
<p>Nose wear</p> 	<p>Nose wear termed also tool-tip blunting, results from insufficient deformation resistance of a tool material in a given machining operation.</p>
<p>Thermal crack</p> 	<p>Thermal cracks develops when the repeated heating and cooling associated with interrupted cutting (thermo-mechanical fatigue), creates high temperature gradients at the cutting edge. With prolonged time, lateral cracks may appear parallel to the cutting edge.</p>
<p>Chipping</p> 	<p>Chipping of the tool, involves removal of relative large discrete particles of tool material. Tool subjected to discontinuous cutting condition are particularly intended to chipping. Built-up edge formation also has a tendency to promote tool chipping. A built-up edge is never completely stable, but it periodically breaks off.</p>
<p>Plastic deformation</p> 	<p>Plastic deformation takes place as a result of combined high temperatures and high pressure on the cutting edge. High speeds and hard workpiece materials mean heat and compression. The typical bulging of the edge will lead to higher temperatures, geometry deformation, chip flow changes and so on until a critical stage is reached.</p>



There are two basic zones of wear in cutting tools: flank wear and crater wear. Flank wear and crater wear are the most important measured forms of tool wear. Flank wear is most commonly used for wear monitoring. According standard ISO 3685:1993 for wear measurements, the major cutting edge is considered to be divided in to four regions, as shown in Figure 2.2:

- Region C is the curved part of the cutting edge at the tool corner;
- Region B is the remaining straight part of the cutting edge in zone C;
- Region A is the quarter of the worn cutting edge length b farthest away from the tool corner;
- Region N extends beyond the area of mutual contact between the tool workpiece for approximately 1-2 mm along the major cutting edge. The wear is notch type.

The width of the flank wear, VB_B is measured within zone B in the cutting edge plane P_S (Figure 2.1) perpendicular to the major cutting edge. The width of the flank wear land is measured from the position of the original major cutting edge. The crater depth, KT , is measured as the maximum distance between the crater bottom and the original face in region B. Tool wear is commonly measured using a toolmaker's microscope (with video imaging systems and resolution of less than 0.001 mm) or stylus instrument similar to a profilometer (with ground diamond styluses). The criteria recommended by ISO 3685:1993 to define the effective tool life is $VB_{B,max} = 0.3$ mm (Davim, 2008).

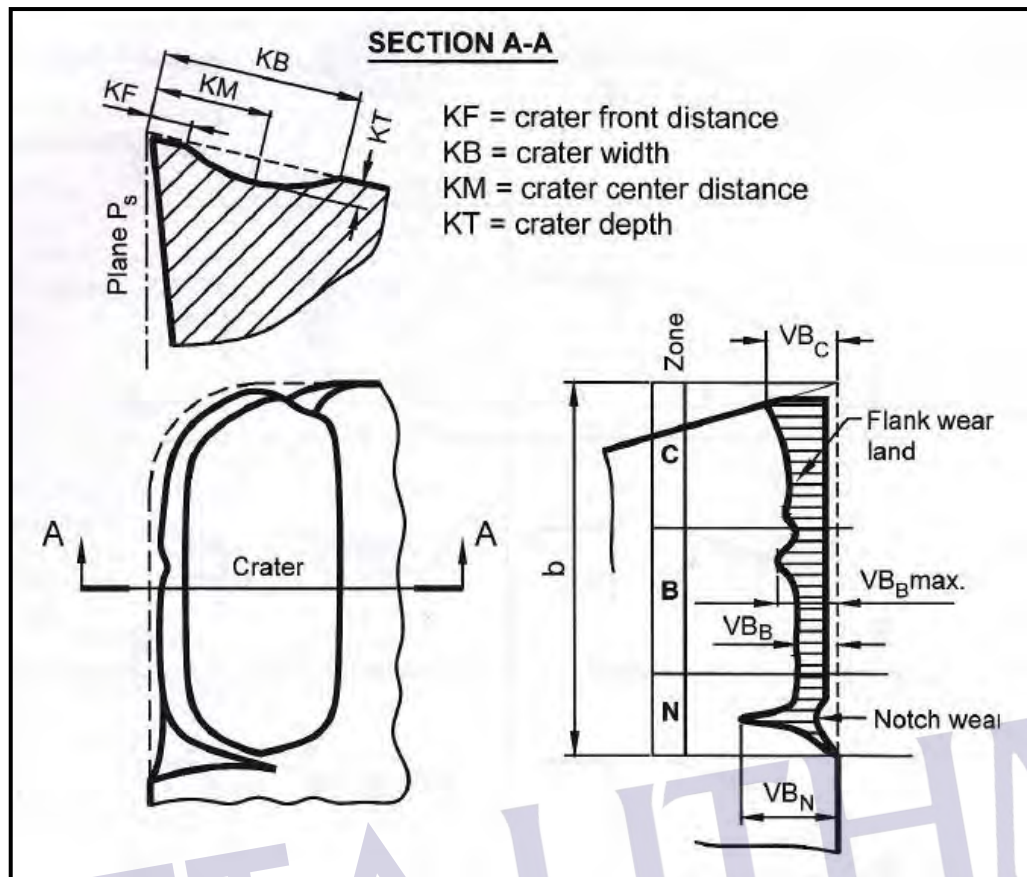

Figure 2.1: Types of tool wear according to standard ISO 3685: 1993 (Davim, 2008)

2.1.2 Tool wear mechanism

The general mechanisms that cause the tool wear is summarized in Figure 2.2. There are abrasion, diffusion, oxidation, fatigue and adhesion. Most of these mechanisms are accelerated at higher cutting speeds and consequently cutting temperatures (Davim, 2008). In the context of cutting tool wear three groups of causes can be qualitatively identified: mechanical, thermal and adhesive. Mechanical types of wear, which include abrasion, chipping, early gross fracture meanwhile mechanical fatigue, are basically independent temperature. Thermal causes with plastic deformation, thermal diffusion and oxygen corrosion as their typical forms, increase drastically at high temperatures and can accelerate the tool failure by easier material removal by abrasion or attrition.

Abrasion wear occurs when hard particles slide against cutting tool, primarily on the flank surface. The hard particles come from either work material's microstructure, or are broken away from the cutting edge by brittle fracture. Moreover, they can also result from a chemical reaction between the chips and cutting fluid when machining steels or cast irons alloyed with chromium. Abrasive wear reduces the harder the tool is relative to the particles in high temperatures, and generally depends on the machining distance. Adhesive or attrition wear are the most significant types of wear at lower cutting speeds. Attrition wear is not a temperature dependent, and is most destructive of the tools in the low cutting speed range, where high speed steels often give equal or superior performance. Attrition may cause substantial changes in surface texture. At high cutting speed, temperature-activated wear mechanisms including diffusion (solution wear), chemical wear (oxidation and corrosion wear), and thermal wear (superficial plastic deformation due to thermal softening effect) occur (Grzesik, 2008).

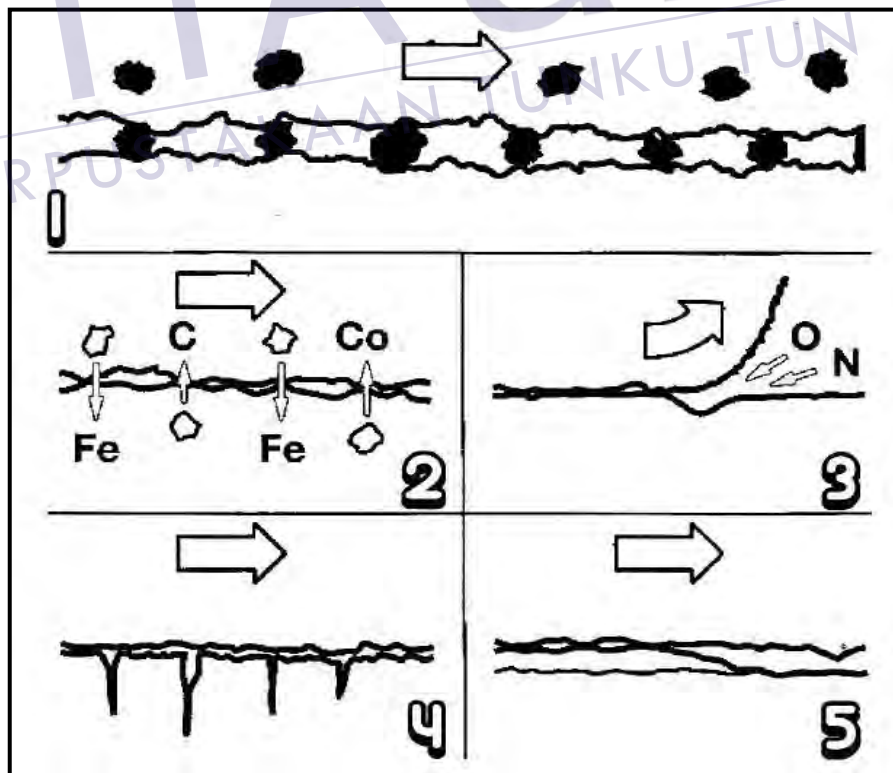

Figure 2.2: Evolution of the flank wear land V_B as a function of cutting time for different cutting speeds (Abburi & Dixit, 2006)

2.1.3 Tool life

Tool life is important in machining since considerable time is lost whenever a tool is replaced and reset. Tool life is the time tool will cut satisfactorily and is expressed as the minutes between changes of the cutting tool. The process of wear and failures of cutting tools increases the surface roughness, and the accuracy of workpieces deteriorates (Davim, 2008). In practical machining operations the wear of the face and flank of the cutting tool is not uniform along the active cutting edge; therefore it is necessary to specify the locations and degree of the wear when deciding on the amount of wear allowable before regrinding the tool (Boothroyd & Knight, 2006). Based on Eq. (2.1) tool life to be measured as total length of cut, LOC (the tool failure criteria is attained, $VB_{max} = 0.3$ mm) divide by feed rate, f_r .

$$TL = \frac{LOC}{f_r} \quad (2.1)$$

where:

TL = Tool life (min)

LOC = Length of cut of material removed (mm)

f_r = Feed rate (mm/min)

2.2 Surface integrity

Surface integrity can be simplistically divided into two parts: first, the external aspects of topography, texture and surface finish and second the internal subsurface aspects of metallurgy, hardness, white layer formation and so on. The concept of surface integrity can be extended to any finishing operations to encompass six different groups of key factors: visual, dimensional, residual stress, tribological, metallurgical and other factors as illustrated in Figure 2.3. It should be noted that all the parameters involved in the hard milling process have a direct

influence on the surface integrity of the part. On the other hand, the six groups of key factors presented in the figure are not random, but are rather deterministic outcome of the manufacturing process performed. In consequence, the determination of basic relationships between mechanical, thermal and chemical aspects of a hard milling process is crucial to successful improvement of a finishing process (Grzesik, 2008).

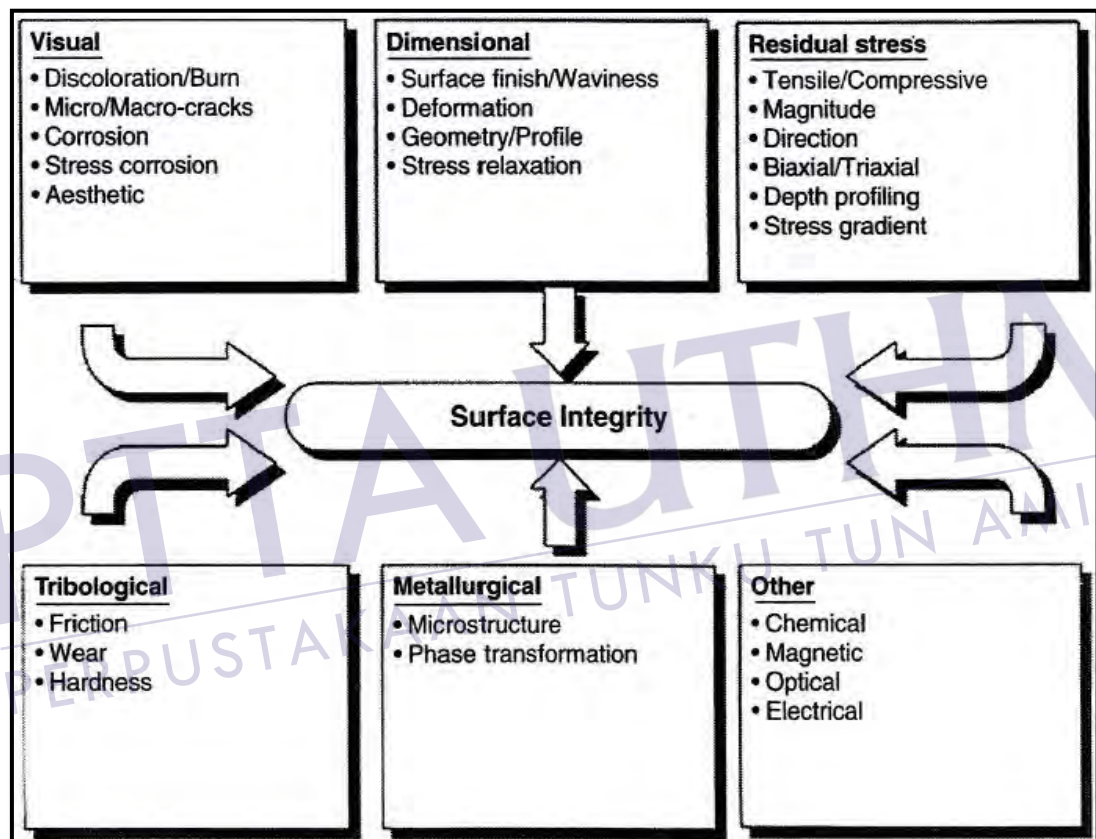

Figure 2.3: The six groups of key factors that define the surface integrity of a finished material (ASM, 1994)

2.2.1 Surface topography

Surface topography is a key factor affecting the function and reliability of a component. The characterization of surface topography has become increasingly important in many fields, such as materials, tribology and machine condition

monitoring. Surface topography characterization is very important for a wide range of applications involved with the control of friction, lubrication, and wears (Yuan et al., 2008). Figure 2.4 illustrates the 3D surface of machine workpiece in milling operation.

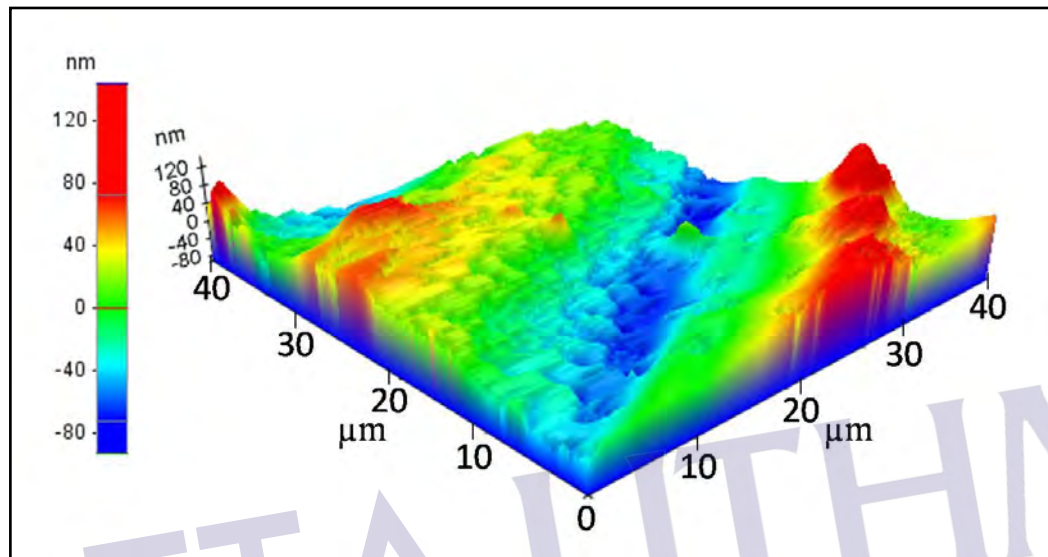

Figure 2.4: 3D surface of machined workpiece

Moreover, engineered component or product must satisfy surface texture requirements (roughness and waviness) and traditionally, surface roughness (mainly arithmetic average, R_a), has been used as one of the principal method to assess quality (Axinte & Dewes, 2002). Therefore, surface roughness has become the most surface topography evaluation in numerous of studies. Surface roughness is referring to high frequency irregularities on the surface caused by the interaction of the material microstructure and the cutting tool action. This relates directly to the manufacturing unit event (the inherent generating mechanisms) and describes the irregularities caused by each feed rate, abrasive grit, particle, or spark. In practice, roughness is never separate with waviness and form, but only superimposed on top of each other. So, these distinctions are therefore qualitative not quantitative. However, roughness results from the manufacturing process rather than machine tool, waviness is attributed to the individual machine and form errors are caused by mutual effects such as insufficient fixturing of the part,

straightness errors of the guideways or thermal distortion of both the tool and the workpiece (Grzesik, 2008).

2.2.2 Surface metallurgy

During the machining operations, the workpiece material is exposed to thermal, mechanical, and chemical energy that can lead to strain aging and recrystallization of the material produce variety alterations of the subsurface layer illustrated schematically in Figure 2.5. Due to the strain aging process, the material might become harder but less ductile, and recrystallization might cause the material to become less hard but more ductile. These thermal (high temperature and rapid quenching) and mechanical (high stress and strain) effects are the main reasons for the microstructural alterations in the material, as well as phase transformations and plastic deformations (Yang & Liu, 1999). The primary important changes, strongly influenced by machining operations and their parameters, are: microstructure and hardness profile changes, as well as the introduced residual stresses. The principal causes of surface alterations are as follows:

1. The high temperature or high temperature gradients developed during the machining process.
2. Plastic deformation and plastically deformed debris.
3. Chemical reactions and subsequent absorption into the machined surface (Gzesik, 2008)



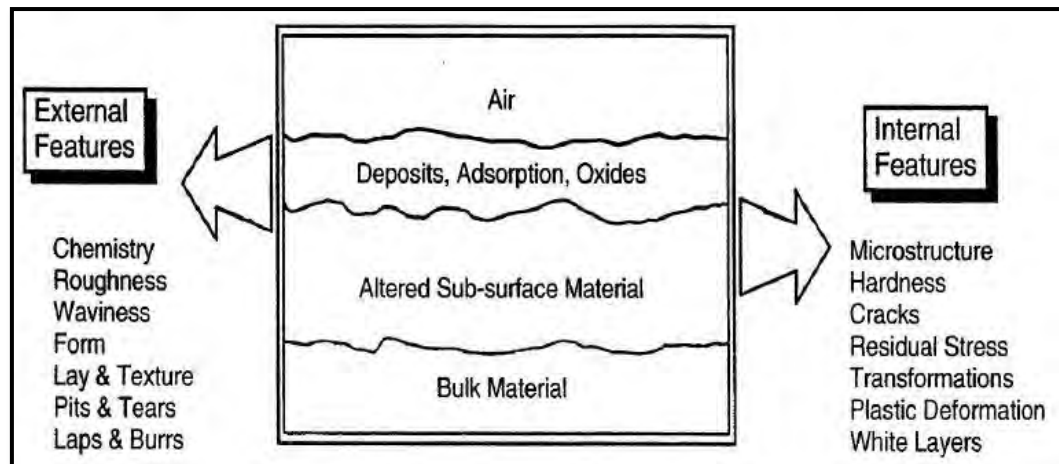

Figure 2.5: Schematic section through a machined surface (Griffiths, 2001)

The main threats to surface integrity come from the plastic deformation of the workpiece during the machining process, and it is essential to study the effects of these deformations. It is known that these deformations are caused and/or supported by many parameters such as cutting parameters (cutting speed, feed, depth of cut), tool parameters (rake angle, edge radius, shape, coating, wear), and workpiece parameters (material, grain size) (Ulutan & Ozel, 2011). Many research studies have been conducted to find the main cause of the plastic deformations on the workpiece. It has been shown that as the tool wears, the plastic deformation on the workpiece increases which contributes in creation of white layers (Che-Haron, 2001; Che-Haron & Jawaid, 2005).

Nevertheless, white layer is a generic term referring to very hard surface layers that, because they are so hard in comparison to the bulk material, appear bland, featureless and therefore 'white' under the microscope. They have been variously described as white phase, hard etching or white etching. They are of many types and at least six classes have been identified. The class produced will depend upon the balance of the thermal, mechanical or chemical unit events, which are related to such factors as strain rate, heating rate, cooling rate and local environmental conditions. Generally one can say that thermal white layer is a particular form of untempered martensite. The term untempered martensite refers to hard surface layers, created by machining processes that resemble martensite in untempered state (Griffiths, 1987). Figure 2.6 shows a FeSEM image of subsurface of machined workpiece.

REFERENCES

- Abburi, N.R. & Dixit, U.S. A knowledge-based system for the prediction of surface roughness in turning process. *Robot Comput-Integr Manuf.* 2006. 22: 363-372.
- Abou-El-Hossein, K.A. & Yahya, Z. High-speed end-milling of AISI 304 stainless steels using new geometrically developed carbide inserts. *Journal of Materials Processing Technology.* 2005. 162-163: 596-602.
- Alauddin, M., El-Baradie, M.A. & Hashmi, M.S.J. Tool life testing in end milling of Inconel 718. *J. Mater. Process. Technol.* 1995. 55: 321–330.
- Amin, A.K.M.N., Dolah, S., Mahmud, M. & Lajis, M.A. Effects of workpiece preheating on surface roughness, chatter and tool performance during end milling of hardened steel D2. *Journal of Materials Processing Technology.* 2008. 201: 466–470.
- Aslan, E. Experimental investigation of cutting tool performance in high speed cutting of hardened X210Cr12 cold work tool steel (62 HRC). *Materials & Design.* 2005. 26: 21-27.
- ASM Handbook. *Surface Engineering Volume 5*, Materials Park: ASM Int. 1994.
- Attanasio, A., Umbrello, D., Cappellini, C., Rotella, G. & M'Saoubi, R. Tool wear effects on white and dark layer formation in hard turning of AISI 52100 steel. *Wear.* 2012. 286– 287: 98– 107.



PTTA UTHM
PERPUSTAKAAN TUN AMINAH

- Axinte, D.A. & Dewes, R.C. Surface integrity of hot work steel after high speed milling-experimental data and empirical models. *Journal of Materials Processing Technology*. 2002. 127: 325-335.
- Baumann, G., Fecht, H.J. & Liebelt, S. Formation of white-etching layers on rail treads. *Wear*. 1996. 191: 133–140.
- Becze, C.E., Clayton, P., Chen, L., El-Wardany, T.I. & Elbestawi, M.A. High-speed five axis milling of hardened tool steel. *International Journal of Machine Tools and Manufacture*. 2000. 40: 869–885.
- Billgreen, P. The use of nitride and carbide coatings on high speed tools. *Speedsteel Technical Report ZSD*. 1984. 22/84
- Birdi, K.S. *Scanning Tunneling Microscopy (STM) and Atomic Force Microscopy (AFM)*, Boca Raton: Lewis. 1996.
- Bouacha, K., Yallese, M.A. & Mabrouki, T. Statistical analysis of surface roughness and cutting forces using response surface methodology in hard turning of AISI 52100 bearing steel with CBN tool. *Int J Refract Met Hard Mater*. 2010. 28: 349–61.
- Boothroyd, G. & Knight, W.A. *Fundamental of Machining and Machine Tools*, Second edition, Boca Raton: CRC Press. 2006.
- Braghini, J.A. & Coelho, R.T. An Investigation of the wear mechanisms of polycrystalline cubic boron nitride (PCBN) tools when end milling hardened steels at low/medium cutting speeds. *The International Journal of Advanced Manufacturing Technology*. 2001.17: 244-257.
- Buj-Corral, I., Vivancos-Calvet, J. & Dominguez-Fernandez, A. Surface topography in ball-end milling processes as a function of feed per tooth and radial depth of cut. *International Journal of Machine Tools & Manufacture*. 2012. 53: 151–159.



Camuscu, N. & Aslan, E. A comparative study on cutting tool performance in end milling of AISI D3 tool steel. *Journal of Materials Processing Technology*. 2005. 170: 121-126.

Che-Haron, C.H. Tool life and surface integrity in turning titanium alloy. *Journal of Materials Processing Technology*. 2001. 118: 231–237.

Che-Haron, C.H., Ghani, J.A., Kassim, M.S., Soon, T.K., Ibrahim, G.A. & Sulaiman, M.A. Surface integrity of Inconel 718 under MQL condition. *Advanced Materials Research*. 2011. vol. 150-151: pp. 1667-1672.

Che-Haron, C.H., Ghani, J.A. & Ibrahim, G.A. Surface integrity of AISI D2 when turned using coated and uncoated carbide tools. *International Journal of Precision Technology*. 2007. 1(1): 106-114.

Che Haron, C.H., Ginting, A. & Arshad, H. Performance of alloyed uncoated and CVD-coated carbide tools in dry milling of titanium alloy Ti-6242S. *Journal of Materials Processing Technology*. 2007. 185: 77–82.

Che-Haron, C.H. & Jawaid, A. The effect of machining on surface integrity of titanium alloy Ti-6% Al-4% V. *Journal of Materials Processing Technology*. 2005. 166: 188–192.

Chen, M., Jing, L. & Li, X. The surface integrity in machining hardened steel SKD11 for die and mold. *Machining Science and Technology*. 2007. 11(1): 99 - 116.

Chien, W.T. & Tsai, C.S. The investigation on the prediction of tool wear and the determination of optimum cutting conditions in machining 17-4PH stainless steel. *Journal of Materials Processing Technology*. 2003. 140: 340 – 345.

Childs, T.H.C., Maekawa, K., Obikawa, T. & Yamane, Y. *Metal machining*, London: Arnold. 2000.



Chevrier, P., Tidu, A., Bolle, B., Cezard, P. & Tinnes, J.P. Investigation of surface integrity in high speed milling of a low alloyed steel. *International Journal of Machine Tools and Manufacture*. 2003. 43: 1135-1142.

Chou, Y.K. Surface hardening of AISI 4340 steel by machining: a preliminary investigation. *Journal of Materials Processing Technology*. 2002. 124: 171–177.

Das, D., Dutta, A.K. & Ray, K.K. Correlation of microstructure with wear behaviour of deep cryogenically treated AISI D2 steel. *Wear*. 2009. 267: 1371–1380.

Davim, J.P. *Machining of Hard Materials*, London: Springer. 2010.

Davim, J.P. *Machining: Fundamental and Recent Advances*, London: Springer. 2008.

Dewes, R.C. & Aspinwall, D.K. A review of ultra high speed milling of hardened steel. *Journal of Material Processing Technology*. 1997. 69: 1-17.

Ding, X.Z., Zeng, X.T. & Liu, Y.C. Structure and properties of CrAlSiN Nanocomposite coatings deposited by lateral rotating cathode arc. *Thin Solid Films*. 2011. 519: 1894-1900.

Diniz, A.E. & Filho, J.C. Influence of the relative positions of tool and workpiece on tool life, tool wear and surface finish in the face milling process. *Wear*. 1999. 232: 67–75.

Ducros, C., Benevent, V. & Sanchette, F. Deposition, characterization and machining performance of multilayer PVD coatings on cemented carbide cutting tools. *Surface and Coatings Technology*. 2003. 163 –164: 681–688.

Dudzinski, D., Devillez, A., Moufki, A., Larrouquere, D., Zerrouki, V. & Vigneau, J. A review of developments towards dry and high speed



PTTA UTHM
PERPUSTAKAAN TEKNIK DAN INDUSTRI

machining of Inconel 718 alloy," *International Journal of Machine Tools and Manufacture*, vol. 44: pp. 439-456.

El-Bestawi, M.A., El-Wardany, T.I., Yan, D. & Tan, M. Performance of whisker-reinforced ceramic tool in milling of nickel-based superalloy. *Ann. CIRP*. 1993. 42 (1): 99–102.

El-Bestawi, M.A., Chen, L., Beeze, C.E. & El-Wardany, T.I. High speed milling of die and mold in their hardened state: A model for chip formation during machining of hardened steel. *Annal of CIRP*. 1997. 46: 57-62.

El-Khabeery, M.M., Saleh, S.M. & Ramadan, M.R. Some observations of surface integrity of deep drilling holes. *Wear*. 1991. 142: 331–349.

El-Wardany, T.I., Kishawy, H.A. & Elbestawi, M.A. Surface Integrity of Die Material in High Speed Hard Machining, Part 1: Micrographical Analysis. *Transactions of the ASME*. 2000: 122.

Endrino, J.L.A., Fox-Rabinovich, G.S.B. & Gey, C. Hard AlTiN, AlCrN PVD coatings for machining of austenitic stainless steel. *Surface & Coatings Technology*. 2006. 200: 6840–6845.

Ezugwu, E.O. & Tang, S.H. Surface abuse when machining cast iron (G-17) and nickel-base superalloy (Inconel 718) with ceramic tools. *Journal of Materials Processing Technology*. 1995. 55: 63–69.

Enzugwu, E.O., Wang, Z.M. & Okeke, C.I. Tool life and surface integrity when machining Inconel 718 with PVD- and CVD-coated tools. *Tribology transactions*. 1999. 42(2): 353-360.

Franco, P., Estrems, M. & Faura, F. Influence of radial and axial runouts on surface roughness in face milling with round insert cutting tools. *International Journal of Machine Tools & Manufacture*. 2004. 44: 1555–1565.



Fnides, B., Yallese, M.A. & Aouici, H. Hard turning of hot work steel AISI H11: evaluation of cutting pressures, resulting force and temperature. *Mech Kaunas Technol Nr.* 2008. 4(72): 59–63.

Fnides, B., Yallese, M.A. & Mabrouki, T. Surface roughness model in turning hardened hot work steel using mixed ceramic tool. *Mech Kaunas Technol Nr.* 2009. 3(77): 68–73.

Fox-Rabinovich, G.S., Yamamoto, Y., Veldhuis, S.C., Kovalev, A.I. & Dosbaeva, G.K. Tribological adaptability of TiAlCrN PVD coatings under high performance dry machining conditions. *Surface & Coatings Technology.* 2005. 200: 1804 – 1813.

Fox-Rabinovich, G.S., Beake, B.D., Endrino, J.L., Veldhuis, S.C., Parkinson, R., Shuster, L.S. & Migranov, M.S. Effect of mechanical properties measured at room and elevated temperatures on the wear resistance of cutting tools with TiAlN and AlCrN coatings. *Surface & Coatings Technology.* 2006. 200: 5738–5742.

Fox-Rabinovich, G.S., Yamamoto, K. Beake, B.D., Kovalev, A.I., Aguirre, M.H., Veldhuis, S.C., Dosbaeva, G.K., Wainstein, D.L, Biksa, A. & Rashkovskiy, A.D. Emergent behavior of nano-multilayered coatings during dry high-speed machining of hardened tool steels. *Surface & Coatings Technology.* 2010. 204: 3425–3435.

Ghani, J.A., Choudhury, I.A. & Masjuki, H.H. Wear mechanism of TiN coated carbide and uncoated cermets tools at high cutting speed applications. *Journal of Material Processing Technology.* 2004. 153-154: 1067-1073.

Gill, J. P., Rose, R. S., Roberts, G. A. & Johnstin, H. G., and George, R. B. *Tool Steels.* The American Society for Metals: Cleveland, Ohio. 1994.



PTTA UTHM
PERPUSTAKAAN TUNKU TUN AMINAH

- Ginting, A. & Nouari, M., (2009) Surface integrity of dry machined titanium alloys. *International Journal of Machine Tools & Manufacture*. 49: 325–332.
- Godet, M., Berthier, Y., Dubourg, M.C. & Vincent, L. (1992) Contact mechanisms: needs for broader applications, *J. Phys. D: Appl. Phys.* 25: A273-A278.
- Gopalsamy, B.M., Mondal, B., Ghosh, S., Arntz, K. & Klocke, F. Experimental investigation while hard machining of DIEVAR tool steel (50 HRC). *Int J Adv Manuf Technol*. 2010. 51(9-12): 853-869.
- Gopalsamy, B.M., Mondal, B., Ghosh, S., Arntz, K. & Klocke, F. Investigations on hard machining of Impax Hi Hard tool steel. *Int J Mater Form*. 2009. 2:145-165.
- Grzesik, W. *Advanced Machining Processes of Metallic Materials: Theory, Modelling and Applications*. First edition, Oxford, UK: Elsevier. 2008.
- Griffiths, B. *Manufacturing Surface Technology: Surface Integrity and Functional Performance*, London: Penton Press. 2001.
- Gu, J., Barber, G., Tung, S. & Gu, R. Tool life and wear mechanism of uncoated and coated milling inserts. *Wear*. 1999. 225–229: 273–284.
- Guerville, L. & Vigneau, J. Influence of machining conditions on residual stresses, in: D. Dudzinski, A. Devillez, A. Moufki, D. Larrouquerre, V. Zerrouki, J. Vigneau (Eds.). A review of developments towards dry and high speed machining of Inconel 718 alloy. *International Journal of Machine Tools and Manufacture*. 2004. 44: 439–456.
- Guo, Y.B. & Janowski, G.M. Microstructural characterization of white layers formed during hard turning and grinding. *Transactions of NAMRI/SME*. 2004. Vol 32.



PTTA AUTHM
PERPUSTAKAAN TUNKU TUKU AMINAH

Guu, Y.H. AFM surface imaging of AISI D2 tool steel machined by the EDM process. *Applied Surface Science*. 2005. 242: 245–250.

Holmberg, K. & Matthews, A. *Coating Tribology: Properties, Mechanisms, Techniques and Applications in Surface Engineering*, Second edition. UK: Elsevier. 2009.

Iqbal, A., Ning, H. & Liang, L. Empirical modeling the effects of cutting parameters in high-speed end milling of hardened AISI D2 under MQL environment. *Proceedings of the World Congress on Engineering*. 2011. Vol I.

Iqbal, A., Ning, H., Khan, I., Liang, L. & Dar, N.U. Modeling the effects of cutting parameters in MQL-employed finish hard-milling process using D-optimal method. *Journal of materials processing technology*. 2008. 199: 379–390.

Iqbal, A., He, N., Li, L & Dar, N.U. A fuzzy expert system for optimizing parameters and predicting performance measures in hard-milling process. *Expert Systems with Applications*. 2007. 32: 1020–1027.

Iyer, R., Koshy, P. & Ng, E. Helical milling: An enabling technology for hard machining precision holes in AISI D2 tool steel. *International Journal of Machine Tools & Manufacture*. 2007. 47: 205–210.

Javidi, A., Rieger, U. & Eichseder, W. The effect of machining on the surface integrity and fatigue life. *International Journal of Fatigue*. 2008. 30: 2050–2055

Jawahir, I.S., Brinksmeier, E., M'Saoubi, R., Aspinwall, D.K., Outeiro, J.C., Meyer, D., Umbrello, D. & Jayal, A.D. Surface integrity in material removal processes: Recent advances. *CIRP Annals - Manufacturing Technology*. 2011. 60: 603–626.

Jennet, N.M. & Gee, M.G. *Mechanical testing of coatings*, In: *Surface Coatings for Protection against Wear*, Mellor, B.G. (ed.), Woodhead Publishing Ltd, Cambridge, UK, 2006, 58-78.

Jeong, Y.G., Kang, M.C., Kim, J.S., Kim, K.H., Kim, W.G., Park, J.D. & Jun, Y.H. Mechanical behavior and cutting performance of nano-multi-layer $Ti_xAl_{1-x}N$ coated tools for high-speed machining of AISI D2 die steel. *Current Applied Physics*. 2009. 9: S272–S275.

Jeong, Y.G., Kang, M.C., Kwon, S.H., Kim, K.H., Kim, H.G. & Kim, J.S. Tool life of nanocomposite Ti–Al–Si–N coated end-mill by hybrid coating system in high speed machining of hardened AISI D2 steel. *Current Applied Physics*. 2009. 9: S141–S144.

Kadirgama, K., Abou-El-Hossein, K.A., Noor, M.M., Sharma, K.V. & Mohammad, B. Tool life and wear mechanism when machining Hastelloy C-22HS. *Wear*. 2011. 270: 258-268.

Kalss, W., Reiter, A., Derflinger, V., Gey, C. & Endrino, J.L. Modern coatings in high performance cutting applications. *International Journal of Refractory Metals & Hard Materials*. 2006. 24: 399–404.

Kang, M.C., Kim, K.H., Shin, S.H, Jang, S.H., Park, J.H. & Kim, C. Effect of the minimum quantity lubrication in high-speed end-milling of AISI D2 cold-worked die steel (62 HRC) by coated carbide tools. *Surface & Coatings Technology*. 2008. 202: 5621–5624.

Kang, M.C., Park, I. & Kim, K.H. Performance evaluation of AIP-TiAlN coated tool for high speed. *Surface and Coatings Technology*. 2003. 163 –164: 734–738.

Katahira, K., Ohmori, H., Komotori, J., Dornfeld, D., Kotani, H., Mizutani, M. Modification of surface properties on a nitride based coating films through



mirror-quality finish grinding. *CIRP Annals - Manufacturing Technology*. 2010. 59: 593–596.

Keunecke, M., Stein, C., Bewilogua, K., Koelker, W., Kassel, D. & van den Berg, H. Modified TiAlN coatings prepared by d.c. pulsed magnetron sputtering. *Surface & Coatings Technology*. 2010. 205: 1273–1278.

Kim, S.W., Lee, D.W., Kang, M.C. & Kim, J.S. Evaluation of machinability by cutting environments in high-speed milling of difficult-to-cut materials. *Journal of Materials Processing Technology*. 2001. 111: 256-260.

Klocke, F. & Eisenblätter, G. Dry Cutting. *CIRP Annals - Manufacturing Technology*. 1997. vol. 46: pp. 519-526.

Klocke, K., Gerschwiler, K., Fritsch, R. & Lung, D. PVD-coated tools and native ester – an advanced system for environmentally friendly machining. *Surface & Coatings Technology*. 2006. 201: 4389–4394

Koshy, P., Dewes, R.C. & Aspinwall D.K. High speed end milling of hardened AISI D2 tool steel (~58 HRC). *Journal of Material Processing Technology*. 2002. 127: 266-273.

Krain, H.R., Sharman, A.R.C. & Ridgway, K. Optimisation of tool life and productivity when end milling Inconel 718TM. *Journal of Materials Processing Technology*. 2007. 189: 153–161.

Lajis, M.A., Karim, M.N.A., Amin, A.K.M.N., Hafiz, A.M.K. & Turnad, L.G. Prediction of tool life in end milling of hardened steel AISI D2. *European Journal of Scientific Research*. 2008. 21(4): 592-602.

Lajis, M.A., Amin, A.K.M.N. & Karim, A.N.M. Surface Integrity in Hot Machining of AISI D2 Hardened Steel. *Advanced Materials Research*. 2012. 500: 44-50.



PTTA UTHM
PERPUSTAKAAN TUN AMINAH

- Liew, W.Y.H. Low-speed milling of stainless steel with TiAlN single-layer and TiAlN/AlCrN nano-multilayer coated carbide tools under different lubrication conditions. *Wear*. 2010. 269: 617-631.
- Liew, W.Y.H, Yuan, S. & Ngoi, B.K.A. Evaluation of machining performance of STAVAX with PCBN tools. *Int J Adv Manuf Technol*. 2004. 23: 11–19.
- Lima, J.G., Avila, R.F., Abrao, A.M., Faustino, M. & Davim, J.P. Hard turning: AISI 4340 high strength low alloy steel and AISI D2 cold work tool steel. *Journal of Material Processing Technology*. 2005. 169: 388-395.
- Liu, K., Li, X.P., Rahman, M. & Liu, X.D. CBN tool wear in ductile cutting of tungsten carbide. *Wear*. 2003. 255: 1344–1351.
- Liu, Z.Q., Ai, X., Zhang, H., Wang, Z.T. & Wan, Y. Wear patterns and mechanisms of cutting tools in high-speed face milling. *Journal of Material Processing Technology*. 2002. 129: 222-226.
- Magonov S.N. & Whangbo, M.H. *Surface Analysis with STM and AFM*. Weinheim, VCH: New York. 1996.
- Marques, M.J., Outeiro, J.C., Dias, A.M., M'Saoubi, R. & Chandrasekaran, H. Surface integrity of H13 ERS mould steel milled by carbide and CBN tools. *Materials Science Forum – Trans Tech Publications*. 2006. 514-516: 564-568.
- Matsumoto, Y., Barash, M. M. & Liu, C. R. Effect of Hardness on the Surface Integrity of AISI 4340 Steel, *Trans. ASME, J. Eng. Ind.* 1986. 108/3: 169–175.
- Ming, C., Jing, L.L. & Lia, X.K. The surface integrity in machining hardened steel SKD11 for die and mold. *International Journal of Machining Science and Technology*. 2007. 11(1): 99-116.



PTIA UTHM
PERPUSTAKAAN TUN AMINAH

- Mo, J.L. & Zhu, M.H. Tribological oxidation behaviour of PVD hard coatings. *Tribology International*. 2009. 42: 1758–1764.
- Mo, J.L., Zhua, M.H., Lei, B., Leng, Y.X. & Huang, N. Comparison of tribological behaviours of AlCrN and TiAlN coatings—Deposited by physical vapor deposition, *Wear*. 2007. 263: 1423–1429.
- Ning, L., Veldhuis, S.C. & Yamamoto, K. Investigation of wear behavior and chip formation for cutting tools with nano-multilayered TiAlCrN/NbN PVD coating. *International Journal of Machine Tools & Manufacture*. 2008. 48: 656–665.
- Nordin, M., Sundstrom, R., Selinder, T.I. & Hogmark, S. Wear and failure mechanisms of multilayered PVD TiN/TaN coated tools when milling austenitic stainless steel. *Surface and Coatings Technology*. 2000. 133-134: 240-246.
- Okada, M., Hosokawa, A., Tanaka, R. & Ueda, T. Cutting performance of PVD-coated carbide and CBN tools in hardmilling. *International Journal of Machine Tools & Manufacture*. 2011. 51: 127–132.
- Ozcelika, B. & Bayramoglu, M. The statistical modeling of surface roughness in high-speed flat end milling. *International Journal of Machine Tools & Manufacture*. 2006. 46: 1395–1402.
- Pavel, R., Marinescu, I., Deis, M. & Pillar, J. Effect of tool wear on surface finish for a case of continuous and interrupted hard turning. *Journal of Materials Processing Technology*. 2005. 170: 341–349.
- Pawade, R.S., Joshi, S.S., Brahmanekar, P.K. & Rahman, M. An investigation of cutting forces and surface damage in high speed turning of Inconel 718. *Journal of Materials Processing Technology*. 2007. 192–193: 139–146.
- Phillips, R.W. *Surf Coat Technol*. 1994. 68–69: 770.



PTTA UTHM
PERPUSTAKAAN TEKNIK DAN INDUSTRI

Poulachon, G., Moisan, A. & Jawahir, I.S. Tool-wear mechanisms in hard turning with polycrystalline cubic boron nitride tools. *Wear*. 2001. 250: 576–586.

Pulker, H.K. *Coatings on glass, Thin Films Science and Technology*. 6. Elsevier: Amsterdam, 484. 1984

Rahim, E.A. & Sasahara, H. An analysis of surface integrity when drilling inconel 718 using palm oil and synthetic ester under MQL condition. *Machining Science and Technology*. 2011. 15 (1): 76 — 90.

Ramakrishna, P.K. & Shunmugam, M.S. Investigation into surface topography, microhardness and residual stress in boring trepanning association machining. *Wear*. 1987. 119: 89–100.

Rao, B., Dandekar, C.R. & Shin, Y.C. An experimental and numerical study on the face milling of Ti–6Al–4V alloy: Tool performance and surface integrity. *Journal of Materials Processing Technology*. 2011. 211: 294–304.

Richetti, A., Machado, A.R., Da Silva, M.B., Ezugwu, E.O. & Bonney, J. Influence of the number of inserts for tool life evaluation in face milling of steels. *International Journal of Machine Tools & Manufacture*. 2004. 44: 695–700.

Rigney, D.A. & Glaeser, W.A. The significance of near surface microstructure in the wear process, *Wear*, 1978, 46: 241–250.

Roberts, G.A., Krauss, G. & Kennedy, R.L. *Tool steels*, Second edition, United States of America: ASMI. 2000.

Roberts, G.A., Hamaker, Jr., J. C. & Johnson, A.R. *Tool Steels*, The American Society for Metals, 3rd edition, Metals, Park: Ohio. 1962.



PTTA UTHM
PERPUSTAKAAN TUNKU TUN AMINAH

Sang-Kyu, L. & Sung-Lim, K. Improvement of the accuracy in the machining of a deep shoulder cut by end milling. *Journal of Material Processing Technology*. 2001. 111: 244-249.

Settineri, L., Faga, M.G., Gautier, G. & Perucca, M. Evaluation of wear resistance of AlSiTiN and AlSiCrN nanocomposite coatings for cutting tools. *CIRP Annals - Manufacturing Technology*. 2008. 57: 575–578.

Sharman, A.R.C., Hughes, J.J. & Ridgway, K. Workpiece surface integrity and tool life issues when turning Inconel 718 nickel based superalloy. *Machining Science and Technology*. 2004. 8 (3): 399 – 414.

Shaw, M.C. *Metal Cutting Principles*, Second edition, Oxford: Oxford University Press. 2005.

Shtansky, D.V., Kiryukhantsev-Korneev, Ph.V., Sheveyko, A.N., Mavrin, B.N., Rojas, C., Fernandez, A. & Levashov, E.A. Comparative investigation of TiAlC(N), TiCrAlC(N), and CrAlC(N) coatings deposited by sputtering of MAX-phase $Ti_{2-x}Cr_xAlC$ targets. *Surface & Coatings Technology*. 2009. 203: 3595–3609.

Siller, H.R., Vila, C., Rodríguez, C.A. & Abellán, J.B. Study of face milling of hardened AISI D3 steel with a special design of carbide tools. *Int J Adv Manuf Technol*. 2009. 40:12–25.

Smith, G.T. *Cutting Tool Technology: Industrial Handbook*. London: Springer. 2008.

Sokovic, M., Kopac, J., Dobrzanski, L.A. & Adamiak, M. Wear of PVD-coated carbide end mills in dry high speed cutting. *Journal of Material Processing Technology*. 2004. 157-158, 422-426.

Stafford, K.N. & Subramaniam, C. (eds), *Quality control and assurance in advanced surface engineering*. The Institute of Materials, The University Press, Cambridge, UK, 113-125. 1997.

Sun, J. & Guo, Y.B. A comprehensive experimental study on surface integrity by end milling Ti-6Al-4V. *Journal of Materials Processing Technology*. 2009. 209: 4036–4042.

Performance Cutting Tools, Sumitomo Electric catalogue.

T. Cselle, *Vacuum's best VIP*. Wiley-VCH Verlag GmbH & Co KGaA: Weinheim. 33.2005.

Takadoun, J. *Materials and Surface Engineering in Tribology*, First edition, London: ISTE. 2008.

Thakare, M.R., Wharton, J.A., Wood, R.J.K. & Menger, C. Effect of abrasive particle size and the influence of microstructure on the wear mechanisms in wear-resistant materials. *Tribol. Int.* 2008. 41: 629.

Tuffy, K., Byrne, G. & Dowling, D. Determination of the optimum TiN coating thickness on WC inserts for machining carbon steels, *Journal of Materials Processing Technology*. 2004. 155–156: 1861–1866.

Tonshoff, K., Karpuschewski, B., Mohlfeld, A., Leyendecker, T., Erkens, G., Fuß, H.G. & Wenke, R. Performance of oxygen-rich TiALON coatings in dry cutting applications, *Surface and Coatings Technology*. 1998. 108–109: 535–542.

Torrance, A.A. & Cameron, A. Surface transformations in scuffing. *Wear*. 1974. 28: 299–311.

Trent, E.M. & Wright, P.K. *Metal Cutting*. Fourth Edition. Newton: Butterworth-Heinemann. 2000.



PTTA AUTHM
PERPUSTAKAAN TEKNIK DAN TEKNOLOGI

- Umbrello, D. & Filice, L. Improving surface integrity in orthogonal machining of hardened AISI 52100 steel by modeling white and dark layers formation. *CIRP Annals - Manufacturing Technology*. 2009. 58: 73–76.
- Ulutan, D. & Ozel, T. Machining induced surface integrity in titanium and nickel alloys: A review. *International Journal of Machine Tools & Manufacture*. 2011. 51: 250–280.
- Veprek, S., Maritz, J.G. & Heijman, V. Industrial applications of superhard nanocomposite coatings. *Surface & Coatings Technology*. 2008. 202: 5063–5073.
- Veldhuis, S.C., Dosbaeva, G.K. & Yamamoto, K. Tribological compatibility and improvement of machining productivity and surface integrity. *Tribology International*. 2009. 42: 1004–1010.
- Venables, J.A. *Introduction to Surface and Thin Solid Film Processes*. First edition. United State of America: Cambridge University Press. 2000.
- Vivancos, J., Luis, C.J., Ortiz, J.A. & Gonzalez H.A. Analysis of factors affecting the high-speed side milling of hardened die steels. *Journal of Materials Processing Technology*. 2005. 162–163: 696–701.
- Vivancos, J., Luis, C.J, Costa, L. & Ort'iz, J.A. Optimal machining parameters selection in high speed milling of hardened steels for injection moulds. *Journal of Materials Processing Technology*. 2004. 155–156: 1505–1512.
- Wei, Q., Yu, Z.M., Ashfold, M.N.R., Chen, Z., Wang, L. & Mac, L. Effects of thickness and cycle parameters on fretting wear behavior of CVD diamond coatings on steel substrates. *Surface & Coatings Technology*. 2010. 205: 158–167.
- Whitehouse, D.J. Theoretical analysis of stylus integration. *Ann. CIRP*. 1974. 23: 181.



PTTA UTHM
PERPUSTAKAAN TUNKU TUN AMINAH

Yang, X. & Liu, C.R. Machining titanium and its alloys. *Machining Science and Technology*. 1999. 3(1): 107–139.

Yazid, M.Z.A., CheHaron, C.H., Ghani, J.A., Ibrahim, G.A. & Said, A.Y.M. Surface integrity of Inconel 718 when finish turning with PVD coated carbide tool under MQL. *Procedia Engineering*. 2011. 19: 396 – 401.

Yu, D., Wang, C., Cheng, X. & Zhang, F. Microstructure and properties of TiAlSiN coatings prepared by hybrid PVD technology. *Thin Solid Films*. 2009. 517: 4950–4955.

Yuan, C.Q., Peng, Z., Yan, X.P. & Zhou, X.C. Surface roughness evolutions in sliding wear process. *Wear*. 2008. 265: 341–348.

Zhang, B., Shen, W., Liu, Y., Tang, X. & Wang, Y. Microstructures of surface white layer and internal white adiabatic shear band. *Wear*. 1997. 211: 164–168.

Zhou, J.M. Bushlya, V. & Stahl, J.E. An investigation of surface damage in the high speed turning of Inconel 718 with use of whisker reinforced ceramic tools. *Journal of Materials Processing Technology*. 2012. 212: 372– 384.

Zou, B., Chen, M., Huang, C. & An, Q. Study on surface damages caused by turning NiCr20TiAl nickel-based alloy. *Journal of Materials Processing Technology*. 2009. 209: 5802–5809.



PT TAAUTHM
PERPUSTAKAAN TUN AMINAH