

LINEAR QUADRATIC GAUSSIAN (LQG) CONTROLLER FOR INVERTED
PENDULUM

NORHIDAYAH BINTI AHMAD

A project report submitted in partial fulfillment of the
requirement for the award of the Degree
Master of Electrical Engineering



Faculty of Electrical and Electronic Engineering
University Tun Hussein Onn Malaysia

JUNE 2013

ABSTRACT

The inverted pendulum is a classical control problem in dynamics and control theory which is the system encounter highly nonlinear and unstable system. Basically, the design of an inverted pendulum system consist of a cart or carriage which it can move horizontally along its track, where there is dc motor embedded in the cart to drive it, while on the cart, there is pendulum that mounted on it. For visualization purpose, the inverted pendulum system had similar concept when trying to balance a broomstick with hand. Since inverted pendulum is unstable system, the controller was introduced. Linear Quadratic Gaussian (LQG) is combination of multivariate function such as Linear Quadratic Regulator (LQR) and Kalman Filter. Linear Quadratic Gaussian (LQG) is developed as an optimal and effective controller that will be used to place cart at desired position and at the same time to make sure the pendulum is always erected in its inverted position during movement of cart. The simulation study was stimulated by using MATLAB and Simulink software. As conclusion, through simulation the inverted pendulum can be stabilized by the LQG controller.



ABSTRAK

Bandul songsang ataupun terbalik adalah masalah kawalan klasik di dalam dinamik dan teori kawalan yang merupakan sistem yang menghadapi masalah dengan, Ini adalah kerana system tersebut adalah yang sangat linear dan tidak stabil. Pada asasnya, reka bentuk sistem bandul terbalik terdiri daripada sebuah kereta atau pengangkutan, dimana kereta tersebut boleh bergerak secara mendatar di sepanjang trek, di mana terdapat motor arus terus tertanam dalam kereta itu untuk membolehkan kereta itu bergerak, manakala pada kereta itu, terdapat bandul yang dipasang di atasnya. Bagi tujuan visualisasi, sistem bandul terbalik mempunyai konsep yang sama apabila cuba untuk mengimbangi batang penyapu dengan tangan. Disebabkan bandul terbalik adalah sistem yang tidak stabil, pengawal diperkenalkan. Linear kuadratik Gaussian (LQG) adalah gabungan fungsi multivariat seperti kawalan kuadratik Linear (LQR) dan Kalman Filter. Linear kuadratik Gaussian (LQG) dibangunkan sebagai pengawal optimum dan berkesan yang akan digunakan untuk meletakkan kereta di kedudukan yang dikehendaki dan pada masa yang sama memastikan bandul sentiasa didirikan dalam kedudukan terbalik semasa pergerakan kereta. Kajian simulasi dirangsang dengan menggunakan MATLAB dan perisian Simulink. Kesimpulannya, melalui simulasi bandul terbalik boleh stabil oleh pengawal LQG.

CONTENTS

TITLE	i
DECLARATION	ii
DEDICATION	iii
ACKNOWLEDGEMENT	iv
ABSTRACT	v
ABSTRAK	vi
TABLE OF CONTENTS	vii
LIST OF TABLES	x
LIST OF FIGURES	xi
LIST OF SYMBOL AND ABBREVIATIONS	xiii
LIST OF APPENDICES	xiv
CHAPTER 1 INTRODUCTION	
1.1 Overview	1
1.2 Problem Statement	2
1.3 Objectives of the project	2
1.4 Project Scope	3
1.5 Thesis outline	3
CHAPTER 2 LITERATURE REVIEW	
2.1 Introduction	5
2.2 Inverted pendulum system	5
2.2.1 Mathematical model of inverted pendulum system	8
2.3 Control theory	11
2.3.1 Linear quadratic optimal	11
2.3.2 State estimation	13

2.3.3	Observability and controllability	15
2.3.4	Kalman filter	16
2.4	System response	17
2.5	Matrix Laboratory software	18
2.6	Microcontroller Arduino Mega 2560	19
2.7	The motor and control circuit	20
2.8	Feedback device	21
2.9	Previous case study	23

CHAPTER 3 METHODOLOGY

3.1	Introduction	26
3.2	Design overview	26
3.3	Mathematical model	28
3.3.1	Inverted pendulum mathematical model	28
3.3.2	Linear quadratic optimal mathematical model	42
3.3.3	Optimal state estimation	44
3.4	Procedure for software approach	50
3.5	Hardware	53
3.5.1	DC gear motor with encoder	53
3.5.2	Analog rotary position sensor	55

CHAPTER 4 RESULT AND ANALYSIS

4.1	Introduction	58
4.2	Inverted pendulum system mathematical model	58
4.2.1	State Space Equation	58
4.2.2	Continuous transfer function	60
4.2.3	Discrete transfer function	60
4.3	Controllability and observability of the system	62
4.4	Inverted pendulum without controller	63
4.5	Optimal Linear Quadratic	65
4.6	Kalman state estimation gain	66
4.7	Steady state LQG controller	66
4.8	Closed loop analysis	67
4.9	Hardware	70

4.9.1	Speed of the motor	70
4.8.2	Encoder direction	71
4.8.3	Angle position	74

CHAPTER 5 CONCLUSION

5.1	Conclusion	76
5.2	Recommendations	77

REFERENCES	78
-------------------	-----------

APPENDIX A: Simulation	81
-------------------------------	-----------

APPENDIX B: Encoder direction	84
--------------------------------------	-----------

APPENDIX C: Reading the sensor value	85
---	-----------

APPENDIX D: Gantt chart for Master Project 1 (PS 1)	86
--	-----------

APPENDIX E: Gantt chart for Master Project 2 (PS 2)	87
--	-----------

VITA



LIST OF TABLES

2.1	Parameter Description in Inverted Pendulum System	9
3.1	Parameter in Inverted Pendulum System	37
4.1	Poles and zeros location for open loop system	63
4.2	Matrix Riccati Equation for 4 phases	64
4.3	Performance Indices for Control System	67
4.4	Poles and zeros location for open loop system	68
4.5	Table of Voltage and Speed of Motor	69
4.6	Encoder sequence for clockwise	71
4.7	Encoder sequence for anti-clockwise	71
4.8	Data for position to voltage	73



LIST OF FIGURES

2.1	Overview Inverted Pendulum System	6
2.2	A Single Pendulum Type	6
2.3	A Double Pendulum Type	7
2.4	Mobile Inverted Pendulum Type	7
2.5	A Rotary Inverted Pendulum Type	7
2.6	Free Body Diagram of Inverted Pendulum	8
2.7	Block Diagram of Discrete-Time Control System	10
2.8	State Space System with Feedback	13
2.9	Observer-State Feedback Control System	14
2.10	Kalman Filter Predictor-Corrector	17
2.11	Transient Response Specification	18
2.12	Pin Description Mega2560	20
2.13	Parts in DC Motor	21
2.14	Encoder Parts	22
3.1	Flow Chart of Project Procedure	27
3.2	Force Applied to Cart	29
3.3	Observer Block Diagram	46
3.4	LQG Block Diagram	48
3.5	Digital Controller System	48
3.6	Simulink for System without Controller	50
3.7	Control System in Simulink	52
3.8	DC Motor SPG30K-20	54
3.9	Connection between Arduino and Motor	54
3.10	Connection for Encoder Test	54
3.11	Connection to Test the Rotary Sensor	55

3.12	Connection for Testing Sensor	55
3.13	Movement of Angle Sign	56
4.1	System without Controller	62
4.2	Poles Location of Position System	63
4.3	Control System for Closed Loop System	66
4.4	Response Specification of Closed Loop System	66
4.5	Poles and Zeros Location for Control System	68
4.6	Speed versus Voltage Graph	70
4.7	Encoder Pulses when Motor+ connect to Power Supply	71
4.8	Analysis Encoder Pulses according Phase for Figure 4.7	72
4.9	Decoder Pulses when Motor+ Connect to Ground	72
4.10	Analysis of Decoder Pulses from Figure 4.9	73
4.11	Voltage versus Position Angle	74



LIST OF SYMBOL AND ABBREVIATIONS

M_c	-	Mass of the cart
M_p	-	Mass of the Pendulum
b	-	Angular Acceleration of the Pendulum
l	-	Length of pendulum
I	-	Moment of inertia of the pendulum
x	-	Position of the cart
\dot{x}	-	Velocity of the Cart
\ddot{x}	-	Acceleration of the Cart
θ	-	Pendulum Angle or Angular Displacement
$\dot{\theta}$	-	Angular Velocity of the Pendulum
$\ddot{\theta}$	-	Angular Acceleration of the Pendulum
Q, R	-	Weighting control
P	-	Steady state Riccati equation for feedback gain
K	-	State feedback gain
R_k, Q_k	-	covariance matrix
P_{kalman}	-	Steady state Riccati equation for Kalman gain
L	-	Kalman gain
LQG	-	Linear Quadratic Gaussian
LQR	-	Linear Quadratic Regulator

LIST OF APPENDICES

APPENDIX	TITLE	
A	Simulation	81
B	Encoder direction	84
C	Reading the sensor value	85
D	Gantt chart for Master Project 1 (PS 1)	86
E	Gantt chart for Master Project 2 (PS 2)	87



PTTA UTHM
PERPUSTAKAAN TUNKU TUN AMINAH

CHAPTER 1

INTRODUCTION

1.1 Overview

The inverted pendulum system is popular and widely used as a benchmark for testing control algorithms area. The system is nonlinear, unstable systems which showcase modern control methods.

The concept of inverted pendulum can visualize through relationship between hand and broom stick. When the broom stick need to balance by hand, the position of hand need to constantly adjust to make sure the broom-stick not fall down. The limitation of this visualize compare to the inverted pendulum system is by control with hand, the hand can move freely while the built inverted pendulum system can only move in one dimension.

The inverted pendulum is encounter instable since even with small disturbance the pendulum will fall down, therefore a controller was introduce to maintain the pendulum in upright position and also eliminate the disturbance either in system or sensor. There are several controllers that can control the inverted pendulum and the controller can be divided into two groups: first the Conventional Controller which is the controllers that include in this group is Proportional Integral Derivative (PID), Linear Quadratic Regulator (LQR) and Linear Quadratic Gaussian (LQG). Secondly the Artificial Intelligence Controller consists of Fuzzy Logic Controller and Artificial Neural Network Controller.

An ideal controller is the controller would keep the pendulum in upright condition with little change in the angle of the pendulum or the cart displacement. But limitations would be imposed based on the actual parameter of the system. Therefore, designing controller that is close to ideal is challenging design problem.

1.2 Problem Statement

Inverted pendulum is a free hung pendulum which is upright and base on ground and it naturally fall downward due to gravity. This is show that the inverted pendulum is inherently unstable system. The inverted pendulum system is combination of linear system (position of cart) and oscillatory dynamic (angle of pendulum).

Practically, in system there must be some noise and other inaccuracies either in plant or in sensor measurement, this inaccuracies and noise can affect the performance of the system. Inverted pendulum system also undergoes this problem. Because of this, with help appropriate controller can reduce the inaccuracies and noise toward the system.

Since inverted pendulum system is unstable and undergoes noise and inaccuracies in the system, in order to stabilize and eliminate the noises in the inverted pendulum, Linear Quadratic Gaussian (LQG) has been studied. LQG are combination of multivariate feedback such as Linear Quadratic Regulator (LQR) with Kalman Filter. Kalman filter is used to estimate the unmeasured variable and to filter those that are directly measured. Then LQR feedback strategy is then used to stabilize the system. Hopefully, with implemented LQG controller in inverted pendulum, the system can be stable.

1.3 Objectives of the project

The objectives of this project are:

- i. To synthesis the mathematical model of the Inverted Pendulum System.
- ii. To design Linear Quadratic Gaussian (LQG) controller for a system.
- iii. To compare the open loop performance with closed loop performance.

1.4 Project scope

The scopes ranges that will be cover in this project are:

- i. Design and implemented the mathematical model of inverted pendulum system.
- ii. Obtain optimal linear quadratic controller gain for a system by using Ricatti equation.
- iii. Implement concept of Kalman filter in system and to design Linear Quadratic Gaussian controller.
- iv. The design of the system and controller was implemented through Matlab software.
- v. Manipulate the control weighting and noise covariance matrix properly to gain better state feedback gain and Kalman gain to give better performance of the system.

1.5 Thesis outline

This thesis consists of five chapters that will explain in more details regarding this project. The first chapter will put in plain words about project overview which are about the project background, problem statement, objectives of the project and scopes of the project.

The second chapter will review about various controllers designed for the inverted pendulum system. In this chapter, the information about the controller and the inverted pendulum system available around the world are gathered. In additional, the previous studies that related to project were use as reference of the project.

The third chapter will discuss in details on the research methodology for this project. The concept and the mathematical model of inverted pendulum without controller were discussed in this chapter. Furthermore, the controller has been used to control the system also been discuss in detail in this chapter.

The fourth chapter will discuss about the result gathered from the project. In addition, the result will be analyzed and the way of solving the problems occurred during this project will be presented.

The fifth chapter which is also the last chapter will deliberate about the conclusion of the project and also the recommendation suggestion is proposed for improvement in the future.



CHAPTER 2

LITERATURE REVIEW

2.1 Introduction

Conducting the literature review is done prior to undertaking the project. Thus, as much information as needed on the technology available and methodologies used by other research counterparts around the world on the related topic are gathered. It shows that previous related studies are important as a reference of the project.

2.2 Inverted pendulum system

The inverted pendulum problem is common problem in the control engineering field. The uniqueness and wide application of the technology derived from this unstable system has drawn interest from many researchers. The inverted pendulum are single input and multiple outputs, nonlinear and unstable system when open loop system [1, 2, 3]. An inverted pendulum is a pendulum which has its center of mass above its pivot point and the pendulum is free hung in upright condition. Generally, the pivot point mounted at the cart or carriage where the cart can move horizontally. Sensors are attached to the cart and pivot to measure the cart position and pendulum angle rotation respectively [1, 3, 4, 9].

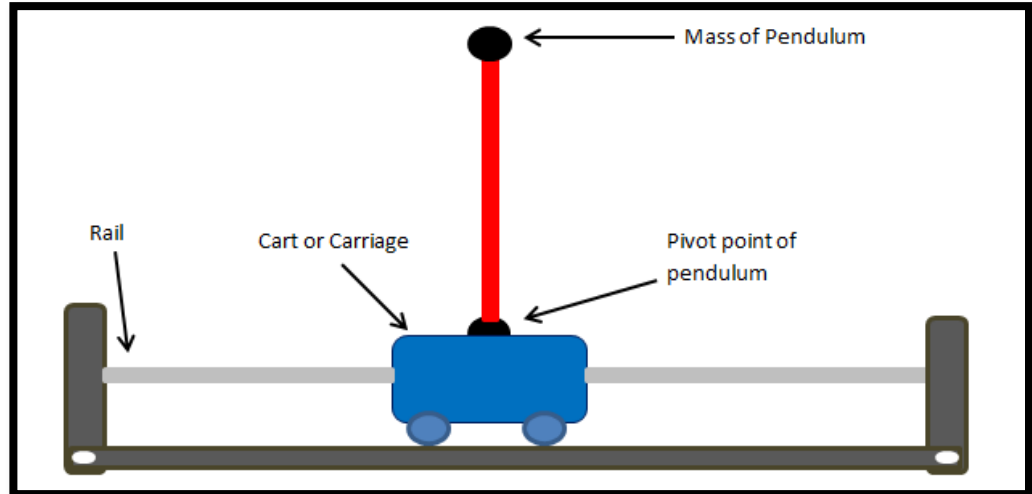

Figure 2. 1: Overview Inverted Pendulum System.

In general, the inverted pendulum system has several types, e.g. a single pendulum, a double pendulum, mobile pendulum, swing up pendulum, etc. Each type has different approach to balance the pendulum.

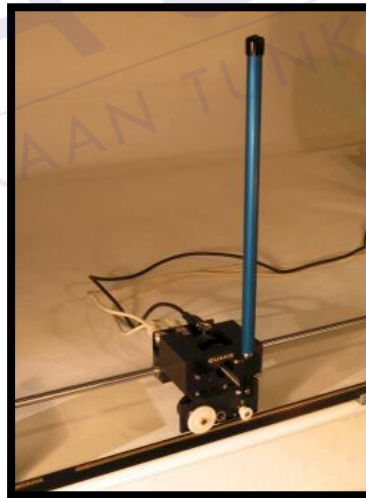

Figure 2. 2: A Single Pendulum Type.

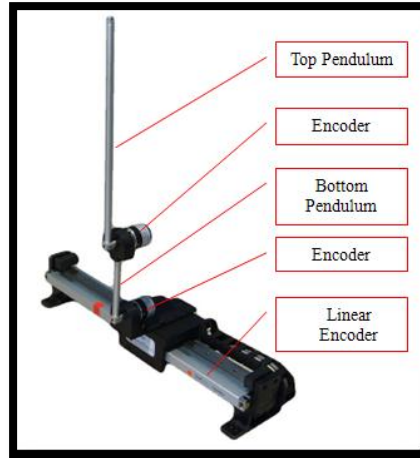

Figure 2. 3: A Double Pendulum Type.



Figure 2. 4: Mobile Inverted Pendulum Type.



Figure 2. 5: A Rotary Inverted Pendulum Type.

Since the inverted pendulum is in upright situation, is naturally easily to fall downward because of gravity. Thus the inverted pendulum system is inherently unstable. In 2-Dimensional system, to stabilize the system it can be done either vertical or horizontal oscillation with certain frequency. While for 3-Dimensional, a rotational arms or free robot arms are used. An addition, for algorithm a controller using feedback system is used to keep the pendulum upright [4, 5]. In order to make sure the inverted pendulum in stable condition, any small changes of horizontal position, Δx in x will resulting to small adjustment of angular position, $\Delta\theta$ in θ is requires so that the pendulum is always erected in its inverted position during any changes has made [7].

2.2.1 Mathematical model of inverted pendulum system

Mathematical descriptions of the inverted pendulum need to derive in order to be able to stimulate the dynamic behaviour of the system [8]. The mathematical model construction is dividing by two parts; there are the cart of pendulum and the pendulum.

The system dynamic equation can be derived by using Newtonian method or Euler-Lagrange method. The Newtonian methods is using free body diagram while the Euler-Lagrange method is defined as the difference between potential and kinetic energy [13].

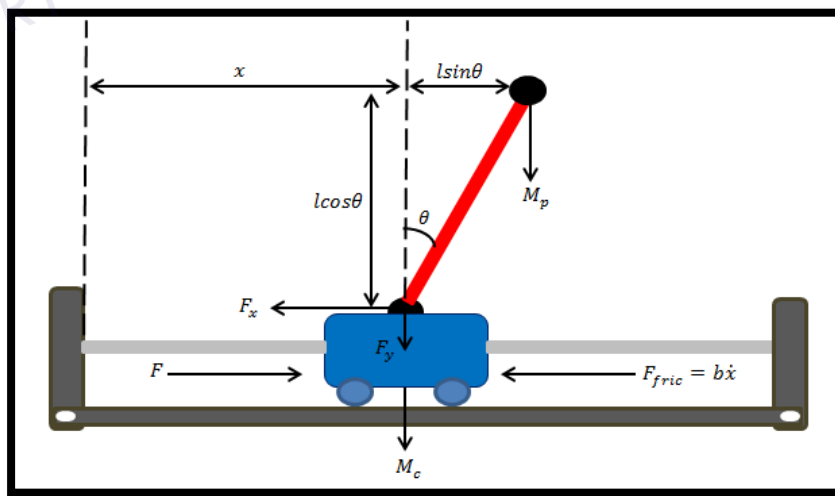

Figure 2. 6: Free Body Diagram of Inverted Pendulum.

By applying the law of dynamic on the inverted pendulum system, the equation of motion are:

$$F = u = (M_c + M_p)\ddot{x} + b\dot{x} + M_p l \ddot{\theta} \cos\theta - M_p \dot{\theta}^2 \sin\theta \quad (2.1)$$

$$\ddot{\theta} = \frac{(-M_p l g \sin\theta - M_p l \ddot{x} \cos\theta)}{(I + M_p l^2)} \quad (2.2)$$

where x is the position of the cart, θ is the pendulum angle or angular displacement, where the pendulum angle measured from the upright position and F is force that applied to cart. In the interest of understanding, Table 2.1 is summarization of the all parameter definition in the equation motion of inverted pendulum.

Table 2. 1: Parameter Description in Inverted Pendulum System.

Parameter	Description
x	Position of the Cart
\dot{x}	Velocity of the Cart
\ddot{x}	Acceleration of the Cart
θ	Pendulum Angle or Angular Displacement
$\dot{\theta}$	Angular Velocity of the Pendulum
$\ddot{\theta}$	Angular Acceleration of the Pendulum
M_c	Mass of the Cart
M_p	Mass of the Pendulum
b	Coefficient of Friction of Cart
l	Length of the Pendulum
I	Mass Moment of Inertia of the Pendulum

Since the angle or angular displacement of pendulum, θ which is the angle, was measured from the vertical line to pendulum, gain small value of angle refer to Figure 2.6, the small-angle approximation to inverted pendulum was applied [15].

The small-angle approximation is a simplification of the basic trigonometry function which is approximately true in the limit where the angle approaches zero and the this approximation can be applied only when a small angle is define $-6^\circ < \theta < 6^\circ$. The small-angle approximation is truncation of the Taylor series for the basic trigonometry functions to a second order approximation. The small angle approximation is:

$$\sin\theta \approx -\theta \quad (2.3)$$

$$\cos\theta \approx -1 + \frac{\theta^2}{2} \approx -1 \quad (2.4)$$

$$\tan\theta \approx -\theta \quad (2.5)$$

This assumption of small angle leads to the linearized equation motion of inverted pendulum and due to linearization, the linear time invariant state space model of the system was derived according to equation (2.6).

$$\dot{\mathbf{x}}(k+1) = \mathbf{A}\mathbf{x}(k) + \mathbf{B}\mathbf{u}(k)$$

$$\mathbf{y}(k) = \mathbf{C}\mathbf{x}(k) + \mathbf{D}\mathbf{u}(k) \quad (2.6)$$

Where \mathbf{A} with $n \times n$ matrix, \mathbf{B} with $n \times r$ matrix, \mathbf{C} with $m \times n$ matrix and \mathbf{D} with $m \times r$ matrix where these matrices need for control design of the system, while \mathbf{u} is input applied to the system and \mathbf{x} is the state variable of the dynamic system where these variables making up the smallest set of variables determine the state of the dynamic system [15,17]. The state space method is based on system equations in terms of n differential equations. The vector-matrix notation is a simplification of the mathematical model of the system. The state space approach also enables the engineer to design a control system with respect to a given performance index and also can include the initial condition in the design. Figure 2.7 shows the block diagram for a discrete-time control system for the state space approach.

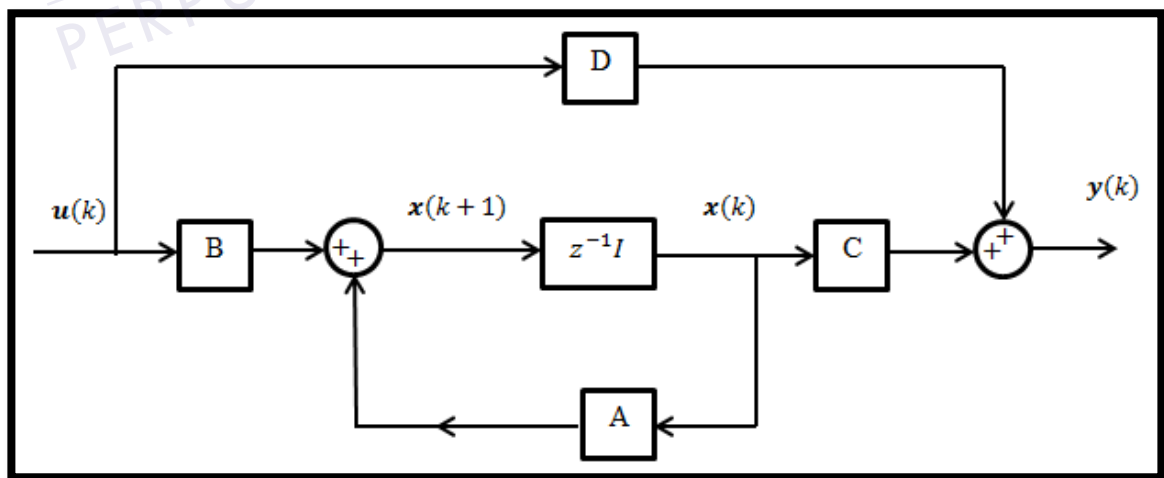

Figure 2. 7: Block Diagram of Discrete-Time Control System.

For inverted pendulum system, the state variables are $[x, \dot{x}, \theta, \dot{\theta}]^T$. The general state space equation for inverted pendulum system is:

$$\begin{bmatrix} \dot{x} \\ \ddot{x} \\ \dot{\theta} \\ \ddot{\theta} \end{bmatrix} = \begin{bmatrix} 0 & 1 & 0 & 0 \\ \frac{(I + M_p l^2)b}{H} & -\frac{M_p^2 l^2 g}{H} & 0 & 0 \\ 0 & 0 & 1 & 0 \\ 0 & \frac{M_p l b}{H} & -\frac{(M_c + M_p)(M_p g l)}{H} & 0 \end{bmatrix} \begin{bmatrix} x \\ \dot{x} \\ \theta \\ \dot{\theta} \end{bmatrix} + \begin{bmatrix} 0 \\ \frac{(I + M_p l^2)b}{H} \\ 0 \\ -\frac{M_p l}{H} \end{bmatrix} \mathbf{u}$$

$$\mathbf{y} = \begin{bmatrix} 1 & 0 & 0 & 0 \\ 0 & 1 & 0 & 0 \\ 0 & 0 & 1 & 0 \\ 0 & 0 & 0 & 1 \end{bmatrix} \begin{bmatrix} x \\ \dot{x} \\ \theta \\ \dot{\theta} \end{bmatrix} + \begin{bmatrix} 0 \\ 0 \\ 0 \\ 0 \end{bmatrix} \mathbf{u} \quad (2.7)$$

2.3 Control Theory

The inverted pendulum is an unstable and nonlinear system. In order to make the pendulum in upright position where the system will be stable, the suitable controller algorithm has to be implemented.

There are several algorithm controllers that can control the inverted pendulum. The algorithm can be divided into two main groups, the conventional controller and the artificial intelligence controller. Under conventional controller are Proportional Integral Derivative (PID) and Linear Quadratic Regulator (LQR)/ Linear Quadratic Gaussian (LQG) while for Artificial Intelligence Controller, there are Fuzzy Logic Controller and Artificial Neural Network Controller.

2.3.1 Linear quadratic optimal

Linear quadratic optimal control is technique that yields the best control system. This technique is assumed that the mathematical function which is called the *cost function or performance index* can be written. The term optimal means that the procedure of this technique is to minimize the cost function, however, in most cases the cost function was

minimized by trial and error method. The general form of performance index equation[18]:

$$J_N = \sum_{k=0}^N \mathbf{x}^T(k) \mathbf{Q}(k) \mathbf{x}(k) + \mathbf{u}^T(k) \mathbf{R}(k) \mathbf{u}(k) \quad (2.8)$$

In the equation above, k is the sample instant and N is the terminal sample instant. Where matrix \mathbf{Q} is a positive semi definite and matrix \mathbf{R} is a positive definite matrix. The matrices \mathbf{Q} and \mathbf{R} determine the relative importance of the error. Then the element of feedback, \mathbf{K} are obtain to minimize the performance index. The control law of feedback is according to figure (2.8):

$$\mathbf{u}(k) = -\mathbf{K}(k) \mathbf{x}(k) \quad (2.9)$$

where the matrix \mathbf{K} is $r \times n$ matrix. In order to obtain the feedback gain, \mathbf{K} to make the controller optimal, the steady state solution of the Riccati equation. The Riccati equation and the feedback gain can be written as:

$$\mathbf{P} = \mathbf{Q} + \mathbf{A}^* \mathbf{P} \mathbf{A} - \mathbf{A}^* \mathbf{P} \mathbf{B} (\mathbf{R} + \mathbf{B}^* \mathbf{P} \mathbf{B})^{-1} \mathbf{B}^* \mathbf{P} \mathbf{A} \quad (2.10)$$

$$\mathbf{K} = (\mathbf{R} + \mathbf{B}^* \mathbf{P} \mathbf{B})^{-1} \mathbf{B}^* \mathbf{P} \mathbf{A} \quad (2.11)$$

In computing the numerical solution of matrix \mathbf{P} , it's important to note that matrix \mathbf{P} is either a Hermitian or a real symmetric matrix and is positive definite.

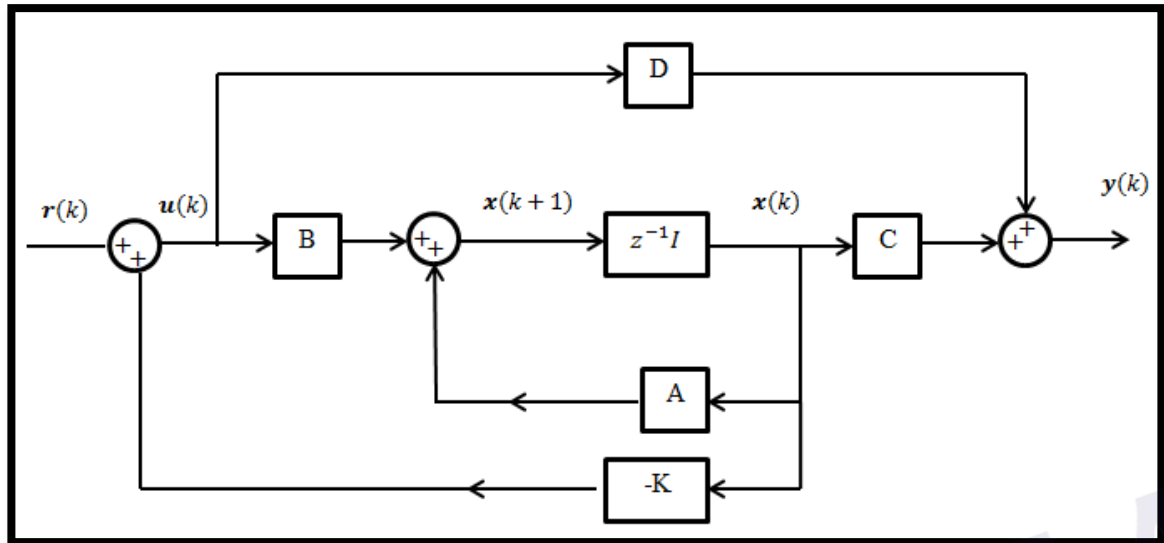

Figure 2. 8: State Space System with Feedback

2.3.2 State estimation

State estimation also known as state observer. In real world, it is possible that all the system states are measured by sensor can send back the information to controller. However, it is possible to estimate the system states from a few measurements and with help the mathematical model to estimate the state variables that are not directly measurable. This method leads to create an observer. In practical, it is necessary to estimate the non-measurable state variables from the output and input of the system [15].

The state variable can be designed if and only if the observability condition satisfied. Figure above show a schematic diagram of a state observer. The state observer will have two input and one output which is $y(k)$ and $u(k)$ as input and $\hat{x}(k)$ as output.

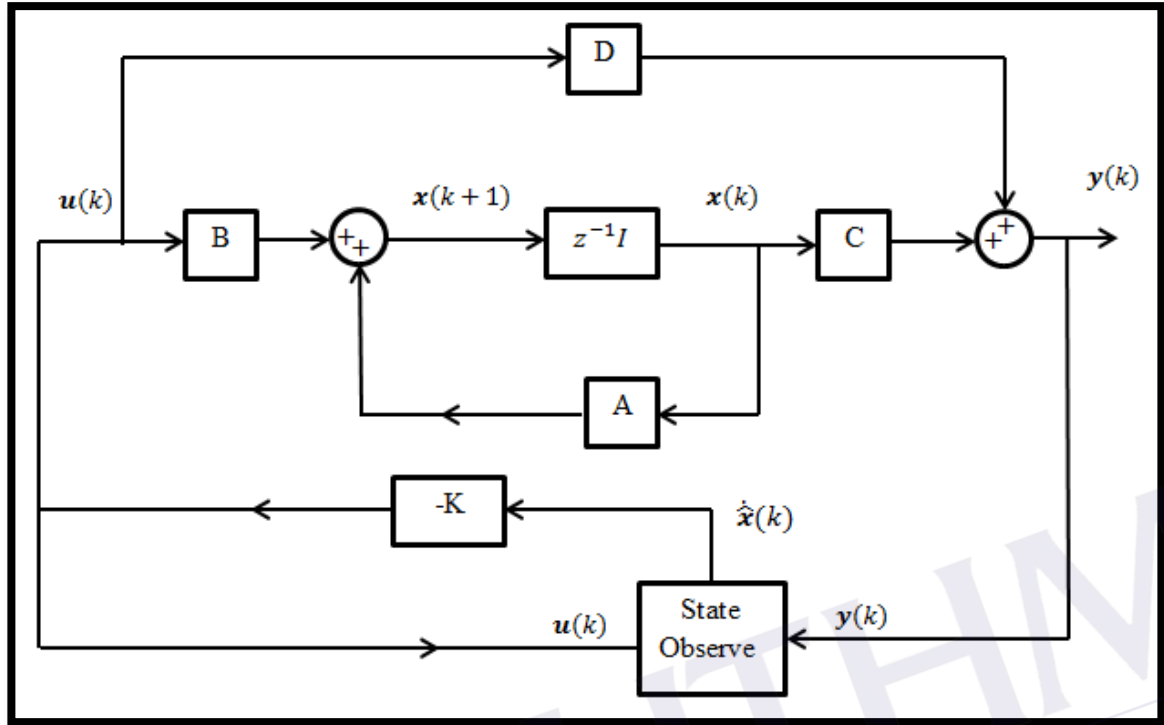

Figure 2. 9: Observer-State Feedback Control System.

State estimation is needed in case the system dynamic suffers from noise. At the system output, noises always exist, by using sensor the value of noise can be measured. Since there are noise in dynamic system, the real output and the output from the model will have a difference. If $y(k)$ is the measured output and $w(k)$ is the measurement noise the following relation holds:

$$y(k) = Cx(k) + Du(k) + w(k) \quad (2.12)$$

So, the observer can be stated as the original state description of the system with the difference that the state vector has been provided with a hat symbol. The equation above shows that the state is estimated.

$$\hat{\dot{x}} = A\hat{x} + Bu \quad (2.13)$$

From the observer state feedback control system, controller estimator transfer function can be obtained. Equation above show the controller estimator transfer function [20].

$$H_{ce}(z) = zK[zI - A + LCA + BK - LCBK]^{-1}G \quad (2.14)$$

2.3.3 Observability and controllability

The concept of observability and controllability was introduced by R.E Kalman. This concept play important role in multivariable systems. The condition of this concept in fact, may manage the existence of a complete solution to an optimal control problem.

The observability is beneficial to solve solution regarding to unmeasured state variables. Observability is concern problem regarding of determining the state of dynamic system from observation of the output and control vector in a limited number of sampling time. The dynamic system said to be observable if, with the system in state $\mathbf{x}(0)$, it is possible to determine this state from observation of the output and control vector in a limited number of sampling time [15,18,25]. For a completely observable system, given $nm \times n$ matrix

$$\mathbf{P} = \begin{bmatrix} \mathbf{C} \\ \mathbf{CA} \\ \vdots \\ \mathbf{CA}^{n-1} \end{bmatrix} \quad (2.15)$$

$$\text{rank}(\mathbf{P}) = n \quad (2.16)$$

Where matrix \mathbf{A} with $n \times n$ matrix and matrix \mathbf{C} with $m \times n$ be of rank n . The rank matrix and the conjugate transpose of the matrix give same answer.

The solution of optimal control problem may not exist if the system not controllable. Controllability is concern with of problem whether it is possible to steer a system from a given initial state to an arbitrary state. The system is controllable if, every state variable can be controlled in finite period by unconstrained control signal. For a completely controllable system, given $n \times nr$ matrix

$$\mathbf{P} = [\mathbf{B} \quad \mathbf{AB} \quad \dots \quad \mathbf{A}^{n-1}\mathbf{B}] \quad (2.17)$$

$$\text{rank}(\mathbf{P}) = n \quad (2.18)$$

Where dimension of matrix \mathbf{A} is $n \times n$ matrix and matrix \mathbf{B} is $n \times r$ matrix is rank of n by getting from row of matrix \mathbf{A} and \mathbf{B} . Other way to test the completeness of the rank of square matrices is to find their determinant. The value of determinant must not equal to zero, in order to conclude the system is observable or controllable.

2.3.4 Kalman filter

Kalman filter is one of the state estimation that can estimate the state variable with the measurement include noise. If the noise is Gaussian distributed, an optimal estimator that minimizes the variance of the estimation error can be derived.

Kalman Filter is a set of mathematical equation that provides an efficient computational means to estimate the state of a process, in a way that minimizes the mean of the squared error. The Kalman filter estimates a process by using a form of feedback control: the filter estimates the process state at some time and then obtains feedback in the form of (noisy) measurements.

Kalman filter fall into two groups: time update equations and measurement update equations. The time update equations are responsible for projecting forward (in time) the current state and error covariance estimates to obtain the a priori estimates for the next time step. The measurement update equations are responsible for the feedback, for incorporating a new measurement into the a priori estimate to obtain an improved a posteriori estimate. The time update equations can also be thought of as predictor equations, while the measurement update equations can be thought of as corrector equations. Indeed the final estimation algorithm resembles that of a predictor-corrector algorithm for solving numerical problems

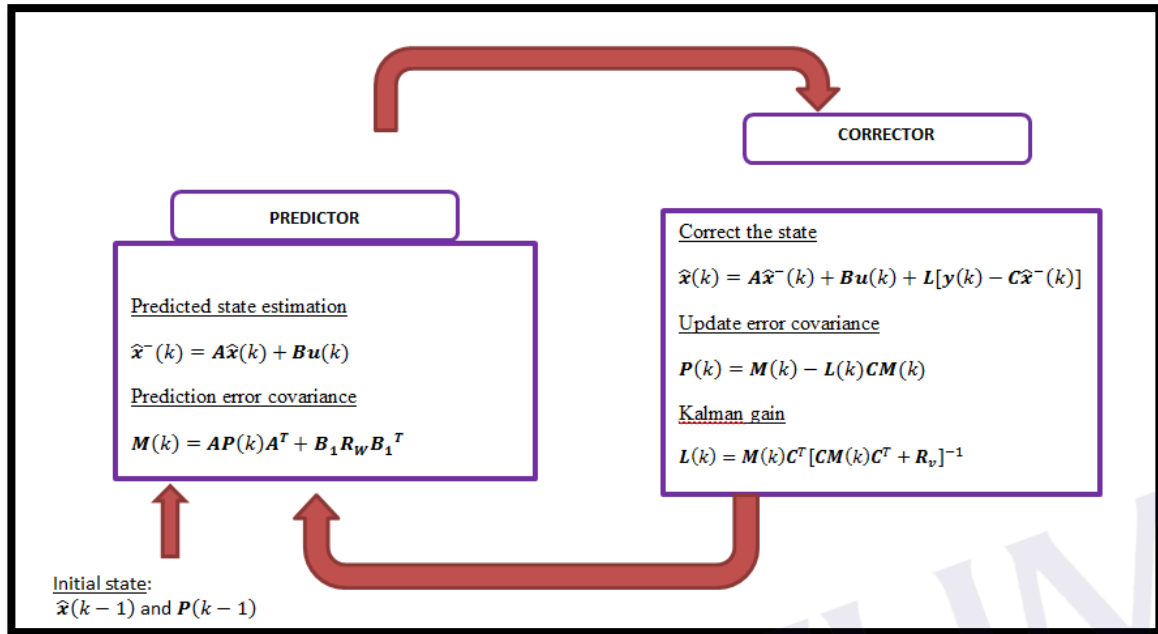

Figure 2. 10: Kalman Filter Predictor-Corrector

2.4 System response

The transient response refers to the portion of the response due to the closed-loop pole of the system. In transient response, the desired performance characteristics of control systems are specified in terms of time domain quantities. The desired performance characteristic of a control system are specified in terms of the transient response to a unit step input, since the unit step is easy to generate and is applicable to provide useful information on both the transient response and the steady state response characteristic of the system.

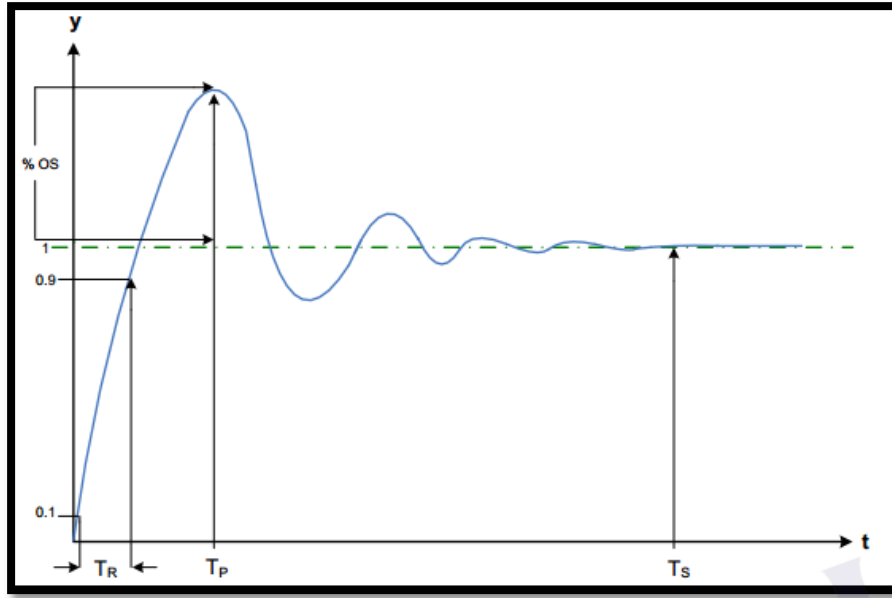

Figure 2. 11: Transient Response Specification.

From transient response specification in figure 2.11 symbol of T_R , T_P , T_S are rise time, peak time and settling time respectively. The rise time is the time required for the response to rise from 10% to 90% of its final value depending on situation. Peak time is the time for the response reach the first peak of the overshoot or undershoots. While the settling time is the time required for the response curve to reach and stay within a range about the final value of a size specified as an absolute percentage of the final value usually 2%.

2.5 Matrix Laboratory software.

MATLAB is a high level language and interactive environment that use on course work and applications, rather than on programming details. MATLAB can be used to analyze and visualize data using automation capabilities, thereby avoiding the manual repetition common with other products. MATLAB can give better understand and apply concepts in a wide range of engineering, science and mathematics application and also signal and image processing, communications, control design, test and measurement, financial modeling and analysis and computational biology.

In MATLAB software, for modeling, simulating and analyzing dynamic systems it is easier by using Simulink approach. Simulink support linear and nonlinear system and systems can also be multirate, that is, the system can have different parts that are sampled or updated at different rates. In Simulink, the software was embedded built-in support for prototyping, testing and running models on low-cost target hardware such as Arduino.

2.6 Microcontroller Arduino Mega 2560

Arduino is a single board microcontroller that usually used in electronic area for hardware project accessible. There are several type of Arduino microcontroller such as serial Arduino, Arduino Extreme, Arduino Diecimilia and many more. Chosen the type of Arduino is depending on the application of the project because different type of Arduino board give with different structure and application.

Arduino board programs are written in C or C++. The Arduino integrated development environment (IDE) comes with a software library called wiring which is it came from the original wiring project. In the programs, user only need to define two functions to make runnable cyclic executive program, that are *setup()* and *loop()* which is *setup()* is a function run at the start of a program. This command is to initialize setting. For *loop()* is a function called repeatedly. The board will run the program nonstop but once the power of the board will stop called the program.

Generally, the Arduino Mega 2560 is microcontroller board based on the ATmega2560. Power supply to operate Arduino board can generate by using USB connection or external power supply. The operating voltage of this board is 5V. The port for digital input or output has 54 pin which 15 pin from it can be apply as PWM outputs and 16 pin for analag input. Figure below show the pin description for Arduino Mega 2560.

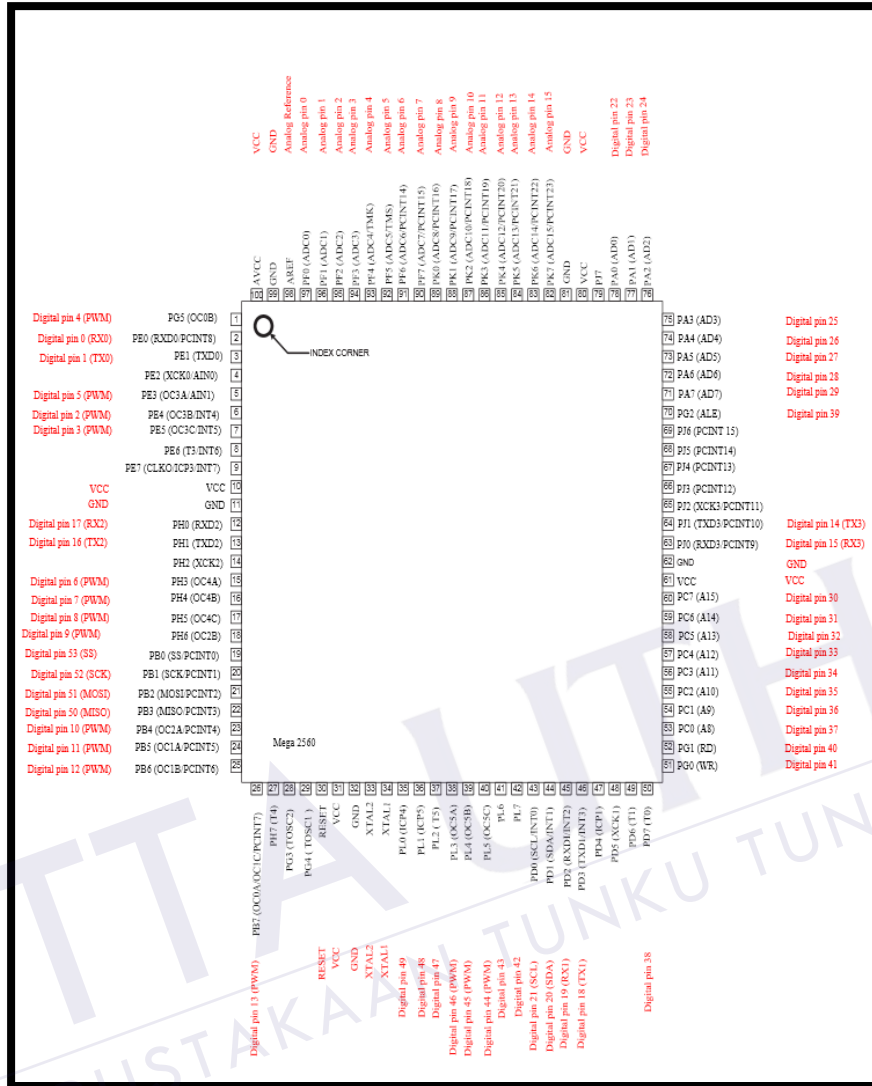

Figure 2. 12: Pin Description Mega2560

2.7 The motor and control circuit

There are three type of motor that commonly use. There are a DC motor, a servo motor and a stepper motor. A DC motor is a mechanically commutated electric motor powered from direct current (DC). Generally, DC motor two basic parts there are rotating part which is called the armature and the stationary part that includes coils of wire called the field coils, the stationary part is called stator.

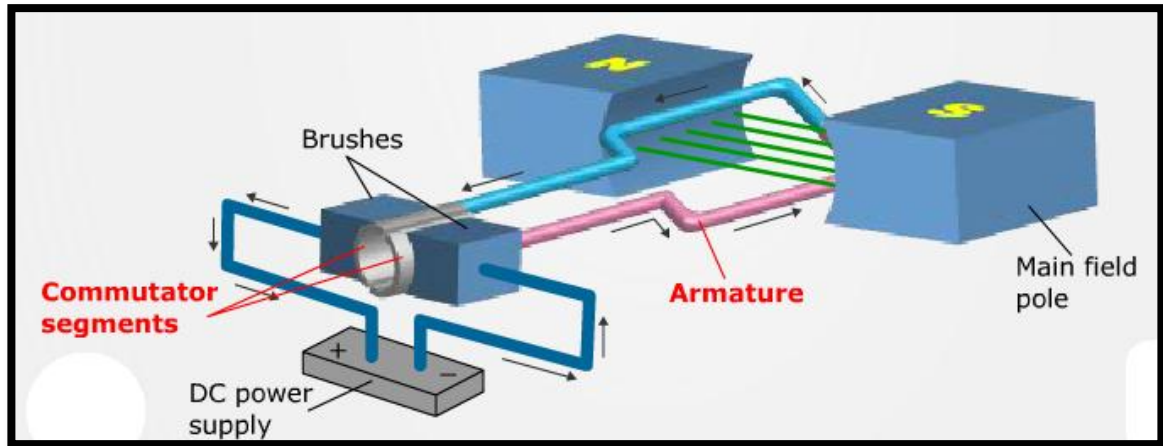

Figure 2. 13: Parts in DC Motor.

Figure above show the DC motor parts. When power was supply to DC motor, the electron flow from negative symbol of power supply to positive sign of power supply. Affected by the electron flow in circuit, the armature will rotate whether in clockwise or counter clockwise and resulting to movement in motor.

Second types of motor are stepper motor. The stepper motor is a brushless, synchronous electric motor that converts digital pulses into mechanical shaft rotation. The stepper motor can only take one step at a time and each step is the same size. Since each pulse causes the motor to rotate a precise angle, hence the motor position can be control without any controller.

The third types are servo motor. Mostly servo motors are used in radio-controlled model airplane, cars, boats and helicopters to control the position of wing flaps and similar devices. Servo motor is geared dc motor with a positional feedback control that allows the rotor to be positioned accurately.

2.8 Feedback device

The objective of feedback device is to eliminate errors introduced by less than perfect transmission that transfer the motor's motion to the load. Sometimes, the feedback device is embedded inside the motor, is that so, it is important to determine the cyclical

and cumulative error associated with the transmission and feedback device to make sure the error is acceptable. In chosen the feedback device or sensor, there are several criteria need to consider. First, the application of the sensor is suitable or not for the project. Second consideration is the type of technology used in the device. For example in semiconductor manufacturing, the sensors need to be very precise in a particular environment to meet high production. The third consideration is geometry. Motion system are either linear, rotational or a combination of both motion.

There is numerous type of feedback device according to the area of application like electric current, vibration and many more. Encoder is one type sensor from electric area. Encoder is categories by three basic categories, that is motion of sensor either rotary or linear, incremental or absolute and by the method of signal generate either optical, magnetic or contacting. Encoder is a device or circuit that converts information from one format to other. Incremental encoder has simple disc pattern which this disk will interrupt light source and phototransistor this process resulting to pulses output. Then the pulses are then fed to counter, where the pulses are count in order to give position information.

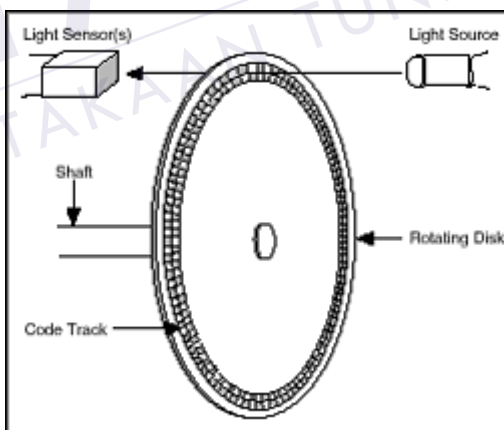

Figure 2. 14: Encoder Parts.

Figure above show the encoder part. The rotating disk that attached to shaft can be either opaque or transparent or either reflective or non-reflective. The light sensor or phototransistor is very sensitive to light. The phototransistor will capture the code from the disk. The light source function is to provide beam of light to other side of rotating disk. Encoder not only can count the position but also the velocity. After the

phototransistor captured the code, encoder will send a known number of signals given angular displacement. By counting the number of signal receive in a given length of time, dt so velocity can be calculated. If the encoder rotate fast, mean the time taken is smaller this resulting to higher effectiveness of the controller.

A rotary encoder which also called shaft encoder is an electric-mechanical device that converts the angular position or motion of a shaft to an analog or digital code. Typically the application of this sensor include temperature control, speed control, position sensing, menu selection and volume control. The rotary encoder can be magnetic, optical or mechanical rotary encoder.

2.9 Previous case study

Title of project: LQG control design for balancing an inverted pendulum mobile robot

Author: Ragnar Eide, Per Magne Egelid, Alexander Stamsø, Hamid Reza Karimi

Synopsis: This paper is to design linear quadratic controller for a mobile robot inverted pendulum. The controller was used in this project is optimal linear quadratic controller which are linear quadratic regulator and linear quadratic Gaussian. The objective of this paper is to determine which optimal linear quadratic controllers bring better performance. The output of the inverted pendulum that had been analyzed is the position of the cart and the angle of the pendulum. For the linear quadratic Gaussian controller, the author used pole placement method in order to determine the best pole that the system should be. The performance was analyze through specific requirement there are, the settling time, T_s should less than 5 seconds, the maximum overshoot is 10 degree (0.175 radian) and the rise time T_r must less than 0.5 seconds. In this project also, there are some assumption made by the authors. The assumptions are there is no friction either between the wheels and the horizontal plane or between the pendulum and the robot. Second assumption is small angle approximation is used and lastly, assume that the sensors for measuring all states are available. The analysis has done by using MATLAB Simulink. As result, both of the controllers give satisfied result but linear quadratic regulator give better result.

Title: Autonomous balancing robot design and construction of a balancing robot.

Author: Christian Sundin and Filip Thorstensson

Synopsis: Purpose of this paper is to design and build a two wheeled upright robot. The robot was embedded with sensors, in order to the robot interact with surrounding the distance sensor in combination with temperature sensor was implemented on it. The robot also has a bowl on top for carrying load purpose. The controller that used to balance the robot is PID controller and linear quadratic Gaussian (LQG) controller. For testing the sensor fusion between the accelerometer and gyro, the Kalman filter and complementary filter was used. As result, Kalman filter was chosen because Kalman filter sufficient for both linear movement and noise of the accelerometer as well as estimate and compensate for the gyros drift and bias. In this project, the microcontroller has been used is Arduino Mega35. Unfortunately, the LQG controller cannot be implementing in hardware this is because Arduino is not fast enough to do calculation for the controller in the required loop time. As result, PID controller was used to balance the robot and it was successful.

Title: Modelling and control design for inverted pendulum

Author: Mr Pankaj Kumar, Mr. Kunal Chakraborty, Mr Rabi Ranjan Mukherje, Mr. Suvobratra Mukherjee.

Synopsis: In this paper, the inverted pendulum has been modeled and there are two controller has been using to balancing the pendulum. The controllers are Porportional, Integral and Derivative (PID) and state feedback controller that is linear quadratic regulator (LQR). The system performance of both controllers was analysis and the better performance of controller was determined. The type of inverted pendulum used is rotary inverted pendulum. The mathematical model of the system was obtained by using Euler-Lagrange's equation. Since the inverted pendulum is nonlinear system, using small angle deviation to linearize the system. The optimal linear quadratic controller was obtaining from pole placement method and manual calculation was shown. The simulation of the

REFERENCE

- [1] Wende Li, Hui Ding, Kai Cheng. An Investigation on the Design and Performance Assessment of double-PID and LQR Controllers for the Inverted Pendulum. *UKACC International Conference on Control 2012 Cardiff, UK*.3-5 September 2012.School of Mechanical-Electrical Engineering Harbin Institute of Technology Harbin,China.
- [2] Narinder Singh, Sandeep Kumar Yadav. Comparison of LQR and PD controller for stabilizing Double Inverted Pendulum System. *International Journal of Engineering Research and Development* ISSN: 2278-067X, Volume 1, Issue 12 (July 2012), PP. 69-74.
- [3] Ragnar Eide, Per Magne Egelid, Alexander Stamsø, Hamid Reza Karimi. LQG Control Design for Balancing an Inverted Pendulum Mobile Robot. *Intelligent Control and Automation*, 2011, 2, 160-166. doi:10.4236/ica.2011.22019.
- [4] Park, Hyeongsu, *Inverted Pendulum*. Korean Minjok Leadership Academy 1334 Sosa Anheung Hoengsung Gangwon, Korea 225-823.
- [5] Nenad Muskinja, Boris Tovornik. Swinging Up and Stabilization of a Real Inverted Pendulum. *Ieee Transactions On Industrial Electronics*, Vol. 53, No. 2, April 2006.
- [6] Zexi Liu. *Design and Simulation of a LQG Optimal Controller for a Mobile Cart*. Department of Electrical & Computer Engineering, Temple University 1801 N. Broad Street, Philadelphia.
- [7] Bytronic International Ltd. (2001). *Documentation for the Bytronic Pendulum Control System*. 3.0 Version. The Courtyard Reddicap Trading Estate Sutton Coldfield. West Midlands, England.

- [8] BJÖRN CARLSSON PER ÖRBÄCK. 2009. *Mobile Inverted Pendulum Control of an Unstable Process Using Open Source Real-Time Operating System* Department of Signals and Systems Division of Automatic Control, Chalmers University Of Technology Gothenburg, Sweden. Master of Science.
- [9] Johnny Lam. *Control of an Inverted Pendulum*.
- [10] Mr.Pankaj Kumar, Mr. KunalChakraborty, Mr. RabiRanjan Mukherjee, Mr.SuvobratraMukherjee.2013. Modelling and Controller Design of Inverted Pendulum. *International Journal of Advanced Research in Computer Engineering & Technology (IJARCET)*. Volume 2, Issue 1, January 2013.
- [11] Rich Chi Ooi. 2003. *Balancing a Two-Wheeled Autonomous Robot*. University of Western Australia. Degree in Mechatronics Engineering.
- [12] Mohamed M. ElMadany, Zuhair S. Abduljabbar. *Linear Quadratic Gaussian Control of a Quarter-Car Suspension*. Mechanical Engineering Department King Saud University.
- [13] M. Amin Sharifi K. *Design, Build and Control of a Single Rotational Inverted Pendulum*. University of Tehran School of Electrical and Computer Engineering. Final Project of Mechatronics.
- [14] John Stang. 2005. *The Inverted Pendulum*. Engineering Division of the Graduate School of Cornell University. Master of Engineering (Electrical).
- [15] Katsuhiko Ogata. *Discrete-Time Control System*. Prentice Hall. Second Edition. (1995).
- [16] J.F. Hauser, A. Saccon. On the driven inverted pendulum. *Proceedings of the 2005 fifth international conference on information, communications and signal processing*. 2005.
- [17] Kwakernaak H., Sivan R., *Linear Optimal Control Systems*. Wiley-Interscience, New York. 1972.
- [18] Frank L.Lewis, Draguna L. Vrabie, Vassilis L. Syrmos. *Optimal Control*. Wiley-Interscience. New York. 2012. Third Edition.
- [19] Peter Dorato, Chaouki Abdullah, Vito Cerone. *Linear Quadratic Control An Introduction*. Prentice Hall, New Jersey. 1996.

- [20] Charles L. Philips, H. Troy Nagle. Digital Control System Analysis and Design. Prentice Hall, New Jersey. 1995.
- [21] Brian D. O Anderson, John B. Moore. Optimal Control Linear Quadratic Methods. Prentice Hall International Editions. 1990.
- [22] B.D.O Anderson, N.K. Bose, E. I. Jury. Output feedback stabilization and related problem. *IEEE Trans. Automat. Contr.* AC-20 (Feb. 1975): 53-66.
- [23] R.E. Kalman, Contribution to the theory of optimal control. *Bol. Soc. Matem. Mex.*5 (1960).
- [24] Antoniou. A, *digital filter: analysis and design*. New York: McGraw Hill. 1979.
- [25] Butman S, R.Sivan, 'On Cancellation, Controllability and Observability', *IEEE Trans. Automatic Control*, AC-9 (1964).
- [26] Luenberger D. G. 'Observing the State of a Linear System'. *IEEE Trans. Automatic Control*, AC-16 (1971).
- [27] Katsuhiko Ogata. *Solving Control Engineering Problem with MATLAB*. Englewood Cliffs, N.J Prentice Hall. 1994.
- [28] Payne, H. J and L. M. Silverman. 'On the Discrete Time Algebraic Riccati Equation. *IEEE Trans. Automatic Control*, AC-18 (1973).
- [29] C.T. Chen, *Introduction to Linear System Theory*, New York. Holt Rinehart and Winston Inc. 1970.
- [30] B. T. Orang, C. L. Philips. 'On the Accuracy of the Stochastic simulation of infinite horizon LQG control systems'. *IEEE Trans Automat Contr*' AC-36 (Apr. 1991)
- [31] W.T. Ried. *Riccati differential equation*' New York. Academic press. 1972.